

USB MagneSafe V5 Flash Swipe Reader

TECHNICAL REFERENCE MANUAL

PART NUMBER 99875531-1

September 2014

MAGTEK[®]

REGISTERED TO ISO 9001:2008

1710 Apollo Court

Seal Beach, CA 90740

Phone: (562) 546-6400

FAX: (562) 546-6301

Technical Support: (651) 415-6800

www.magtek.com

Information in this document is subject to change without notice. No part of this document may be reproduced or transmitted in any form or by any means, electronic or mechanical, for any purpose, without the express written permission of MagTek, Inc.

MagTek is a registered trademark of MagTek, Inc.
MagnePrint is a registered trademark of MagTek, Inc.
MagneSafe™ is a trademark of MagTek, Inc.
Magensa™ is a trademark of MagTek, Inc.

REVISIONS

Rev Number	Date	Notes
1.02	9/11/14	Updated bullet 7 and 9 under Features
1.01	3/31/2011	Initial release

LIMITED WARRANTY

MagTek warrants that the products sold pursuant to this Agreement will perform in accordance with MagTek's published specifications. This warranty shall be provided only for a period of one year from the date of the shipment of the product from MagTek (the "Warranty Period"). This warranty shall apply only to the "Buyer" (the original purchaser, unless that entity resells the product as authorized by MagTek, in which event this warranty shall apply only to the first repurchaser).

During the Warranty Period, should this product fail to conform to MagTek's specifications, MagTek will, at its option, repair or replace this product at no additional charge except as set forth below. Repair parts and replacement products will be furnished on an exchange basis and will be either reconditioned or new. All replaced parts and products become the property of MagTek. This limited warranty does not include service to repair damage to the product resulting from accident, disaster, unreasonable use, misuse, abuse, negligence, or modification of the product not authorized by MagTek. MagTek reserves the right to examine the alleged defective goods to determine whether the warranty is applicable.

Without limiting the generality of the foregoing, MagTek specifically disclaims any liability or warranty for goods resold in other than MagTek's original packages, and for goods modified, altered, or treated without authorization by MagTek.

Service may be obtained by delivering the product during the warranty period to MagTek (1710 Apollo Court, Seal Beach, CA 90740). If this product is delivered by mail or by an equivalent shipping carrier, the customer agrees to insure the product or assume the risk of loss or damage in transit, to prepay shipping charges to the warranty service location, and to use the original shipping container or equivalent. MagTek will return the product, prepaid, via a three (3) day shipping service. A Return Material Authorization ("RMA") number must accompany all returns. Buyers may obtain an RMA number by contacting Technical Support at (888) 624-8350.

EACH BUYER UNDERSTANDS THAT THIS MAGTEK PRODUCT IS OFFERED AS IS. MAGTEK MAKES NO OTHER WARRANTY, EXPRESS OR IMPLIED, AND MAGTEK DISCLAIMS ANY WARRANTY OF ANY OTHER KIND, INCLUDING ANY WARRANTY OF MERCHANTABILITY OR FITNESS FOR A PARTICULAR PURPOSE.

IF THIS PRODUCT DOES NOT CONFORM TO MAGTEK'S SPECIFICATIONS, THE SOLE REMEDY SHALL BE REPAIR OR REPLACEMENT AS PROVIDED ABOVE. MAGTEK'S LIABILITY, IF ANY, SHALL IN NO EVENT EXCEED THE TOTAL AMOUNT PAID TO MAGTEK UNDER THIS AGREEMENT. IN NO EVENT WILL MAGTEK BE LIABLE TO THE BUYER FOR ANY DAMAGES, INCLUDING ANY LOST PROFITS, LOST SAVINGS, OR OTHER INCIDENTAL OR CONSEQUENTIAL DAMAGES ARISING OUT OF THE USE OF, OR INABILITY TO USE, SUCH PRODUCT, EVEN IF MAGTEK HAS BEEN ADVISED OF THE POSSIBILITY OF SUCH DAMAGES, OR FOR ANY CLAIM BY ANY OTHER PARTY.

LIMITATION ON LIABILITY

EXCEPT AS PROVIDED IN THE SECTIONS RELATING TO MAGTEK'S LIMITED WARRANTY, MAGTEK'S LIABILITY UNDER THIS AGREEMENT IS LIMITED TO THE CONTRACT PRICE OF THIS PRODUCT.

MAGTEK MAKES NO OTHER WARRANTIES WITH RESPECT TO THE PRODUCT, EXPRESSED OR IMPLIED, EXCEPT AS MAY BE STATED IN THIS AGREEMENT, AND MAGTEK DISCLAIMS ANY IMPLIED WARRANTY, INCLUDING WITHOUT LIMITATION ANY IMPLIED WARRANTY OF MERCHANTABILITY OR FITNESS FOR A PARTICULAR PURPOSE.

MAGTEK SHALL NOT BE LIABLE FOR CONTINGENT, INCIDENTAL, OR CONSEQUENTIAL DAMAGES TO PERSONS OR PROPERTY. MAGTEK FURTHER LIMITS ITS LIABILITY OF ANY KIND WITH RESPECT TO THE PRODUCT, INCLUDING ANY NEGLIGENCE ON ITS PART, TO THE CONTRACT PRICE FOR THE GOODS.

MAGTEK'S SOLE LIABILITY AND BUYER'S EXCLUSIVE REMEDIES ARE STATED IN THIS SECTION AND IN THE SECTION RELATING TO MAGTEK'S LIMITED WARRANTY.

FCC WARNING STATEMENT

This equipment has been tested and was found to comply with the limits for a Class B digital device pursuant to Part 15 of FCC Rules. These limits are designed to provide reasonable protection against harmful interference when the equipment is operated in a residential environment. This equipment generates, uses, and can radiate radio frequency energy and, if not installed and used in accordance with the instruction manual, may cause harmful interference with radio communications. However, there is no guarantee that interference will not occur in a particular installation.

FCC COMPLIANCE STATEMENT

This device complies with Part 15 of the FCC Rules. Operation of this device is subject to the following two conditions: (1) this device may not cause harmful interference, and (2) this device must accept any interference received, including interference that may cause undesired operation.

CANADIAN DOC STATEMENT

This digital apparatus does not exceed the Class B limits for radio noise from digital apparatus set out in the Radio Interference Regulations of the Canadian Department of Communications.

Le présent appareil numérique n'émet pas de bruits radioélectriques dépassant les limites applicables aux appareils numériques de la classe B prescrites dans le Règlement sur le brouillage radioélectrique édicté par le ministère des Communications du Canada.

This Class B digital apparatus complies with Canadian ICES-003.

Cet appareil numérique de la classe B est conforme à la norme NMB-003 du Canada.

CE STANDARDS

Testing for compliance with CE requirements was performed by an independent laboratory. The unit under test was found compliant with standards established for Class B devices.

UL/CSA

This product is recognized per Underwriter Laboratories and Canadian Underwriter Laboratories 1950.

RoHS STATEMENT

When ordered as RoHS compliant, this product meets the Electrical and Electronic Equipment (EEE) Reduction of Hazardous Substances (RoHS) European Directive 2002/95/EC. The marking is clearly recognizable, either as written words like "Pb-free", "lead-free", or as another clear symbol ().

Table of Contents

SECTION 1. FEATURES AND SPECIFICATIONS	1
FEATURES.....	2
HARDWARE CONFIGURATION	2
ACCESSORIES.....	2
REFERENCE DOCUMENTS	3
SPECIFICATIONS.....	4
SECTION 2. INSTALLATION	5
WINDOWS PLUG AND PLAY SETUP.....	5
SECTION 3. OPERATION	7
USER SWITCH.....	7
LED INDICATOR.....	7
Standalone Operation.....	7
USB Charging Only Operation.....	7
USB Operation.....	7
Battery Charging.....	7
Card Reading.....	7
CARD READ.....	8
READER STATES.....	8
CHARGING THE READER BATTERY	9

Tables and Figures

Figure 1-1. MagneSafe V5 FLASH Reader	vi
Table 1-1. Specifications.....	4
Figure 1-2. Dimensions for the MagneSafe FLASH Reader.....	4



Figure 1-1. Flash MagneSafe Reader

SECTION 1. FEATURES AND SPECIFICATIONS

The Flash MagneSafe V5 Swipe Reader is compact, handheld magnetic stripe card readers that conform to ISO standards. In addition to reading and storing multiple transactions, this Reader also includes MagnePrint technology and data encryption. The MagnePrint data will be included with the track data on each transaction. In order to maximize card security, the Reader incorporates data encryption to protect the card contents and MagnePrint information. The Reader is compatible with any device having a host USB interface. A card is read in the swipe reader by sliding it, stripe down and facing towards the LED, through the slot either forward or backward.

An LED (Light Emitting Diode) indicator on the Reader panel provides the operator with continuous status of the Reader operations.

The reader conforms to the USB HID (Human Interface Device) Class specification Version 1.1. This allows host applications designed for most versions of Windows to easily communicate to the readers using standard Windows API calls that communicate to the reader through the HID driver that comes with Windows.

When a card is swiped through the Reader, the track data and MagnePrint information will be TDEA (Triple Data Encryption Algorithm, aka, Triple DES) encrypted using DUKPT (Derived Unique Key Per Transaction) key management. This method of key management uses a base derivation key to encrypt a key serial number that produces an initial encryption key which is injected into the Reader prior to deployment. After each transaction, the encryption key is modified per the DUKPT algorithm so that each transaction uses a unique key. Thus, the data will be encrypted with a different encryption key for each transaction. The data collected from each transaction will be encrypted and securely stored in the memory so that it can be downloaded when the reader is connected to a computer through a USB port.

FEATURES

Major features of the Flash MagneSafe Reader are as follows:

- Powered by a rechargeable battery; recharging can be provided via a standard USB cable
- Compatible with any device having a host USB (Universal Serial Bus) interface
- Bi-directional card reading
- Reads encoded data that meets ANSI/ISO/AAMVA standards and some custom formats such as ISO track 1 format on track 2 or 3
- Reads up to three tracks of card data
- Red/Green/Amber LED for status
- Battery charge can outlast memory and lasts for hundreds of transactions
- Non-volatile memory for property storage
- Non-volatile storage of up to 71 transactions before downloading to the host (even if the battery becomes discharged)
- Industry standard USB micro-B connector
- Compatible with USB specification Revision 1.1
- Compatible with HID specification Version 1.1
- Can use standard Windows HID driver for communications; no third party device driver is required
- Programmable USB Interrupt In Endpoint polling interval
- Supplies 54 byte MagnePrint™ value
- Contains a unique, non-changeable device serial number which allows tracking each reader
- Encrypts all track data and the MagnePrint value
- Provides clear text confirmation data including card holder's name, expiration date, and a selectable portion of the PAN as part of the Masked Track Data
- Provides MagneSafe 2.0 format

HARDWARE CONFIGURATION

The hardware configuration is as follows:

Part Number	Tracks	Style	Interface	Cable
21073081	1, 2, 3	Portable	USB	N/R*

* No cable is required to operate the reader but one of the cables listed below can be used to retrieve transactions and to charge the battery.

ACCESSORIES

The optional accessories are as follows:

Part Number	Description	Notes
21051543	USB-A TO USB-Micro-B Black, 700mm Retractable Cable	Optional Cable
21051548	USB-A TO USB-Micro-B Black, 6' Cable	Supplied with reader

REFERENCE DOCUMENTS

MagTek Communication Reference Manual for USB MagneSafe V5 Readers (99875475)

ANS X9.24-2004 Retail Financial Services Symmetric Key Management Part 1: Using Symmetric Techniques

USB Human Interface Device (HID) Class Specification Version 1.1.

Universal Serial Bus (USB): HID Usage Tables Version 1.12 (1/21/2005)

USB (Universal Serial Bus) Specification, Version 1.1, Copyright© 1998 by Compaq Computer Corporation, Intel Corporation, Microsoft Corporation, NEC Corporation.

USB Implementers Forum, Inc., www.usb.org.

SPECIFICATIONS

Table 1-1 lists the specifications for the MagneSafe V5 Flash Reader. Figure 1-2 shows the dimensions of the Reader.

Table 1-1. Specifications

Reference Standards	ISO 7810 and ISO 7811; AAMVA*
Power Input	USB port or 5 VDC for battery charging
Recording Method	Two-frequency coherent phase (F2F)
Message Format	ASCII
Card Speed	4 to 60 ips (10.1 to 152.4 cm/s)
Battery Characteristics	3.7V, 120 mAh Li-ion Polymer Battery
Time to Charge Battery	About 2.5 hours (from a fully discharged state)
Card Swipes per Full Charge	Over 100 swipes
ELECTRICAL	
Current	100mA maximum during charge
MECHANICAL	
Dimensions	Length 2.68" (68.07mm) Width 0.65" (16.51mm) Height 1.35" (34.29mm)
Weight	1.4 oz. (39.7 gr)
Cable length	6'
Connector	USB Micro B
ENVIRONMENTAL	
Temperature	
Operating	32 °F to 113 °F (0 °C to 45 °C)
Storage	-4 °F to 140 °F (-20 °C to 60 °C)
Humidity	
Operating	10% to 90% noncondensing
Storage	10% to 90% noncondensing

* ISO (International Standards Organization) and AAMVA (American Association of Motor Vehicle Administrators).

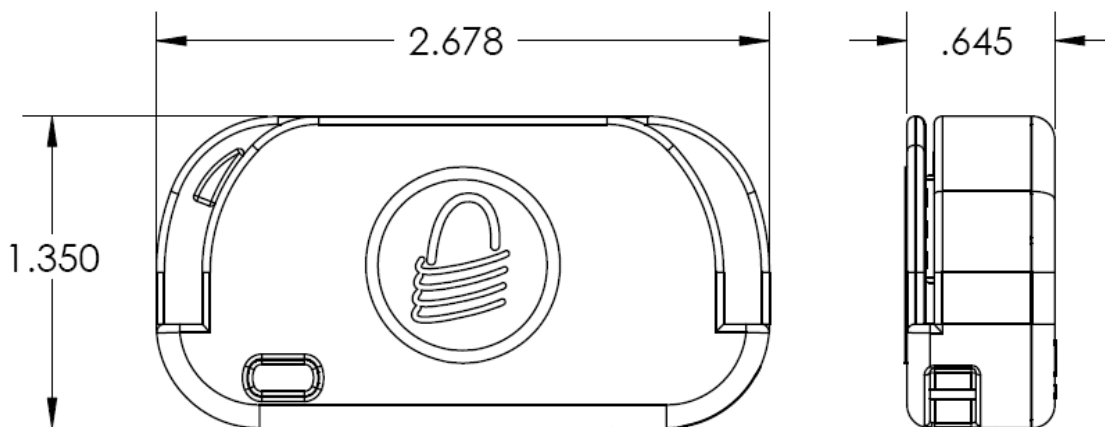

Figure 1-2. Dimensions for the Flash Reader

SECTION 2. INSTALLATION

This section describes the Windows Plug and Play Setup.

WINDOWS PLUG AND PLAY SETUP

On hosts with the Windows operating system, the first time the reader is plugged into a specific USB port, Windows will pop up a dialog box, which will guide you through the process of installing a device driver for the reader. After this process is completed once, Windows will no longer request this process as long as the reader is plugged into the same USB port. The device driver that Windows will install for this reader is the driver used for HID devices and it is part of the Windows operating system. When the dialog box pops up, follow the instructions given. Sometimes Windows will find all the files it needs on its own without giving any prompts. Other times Windows will need to know the location of the files it needs. If Windows prompts for the file locations, insert the CD that was used to install Windows on your PC and point Windows to the root directory of the CD. Windows should find all the files it needs there.

SECTION 3. OPERATION

USER SWITCH

The User Switch, or Power Switch, is located on the side of the reader. Pressing the User Switch when the reader is off will turn the reader on. The reader will stay on for a predetermined amount of time (the default is 60 seconds) or until the completion of a card read transaction. Pressing the User Switch and holding for approximately one second when the reader is on will extend the Activity Timer to its full period, avoiding having the reader turn off due to inactivity.

If the power is already on, pressing the User Switch and holding it for three seconds will turn the reader off.

LED INDICATOR

Standalone Operation

When the reader is not attached to a USB cable it operates in Standalone mode. In this mode, with the battery sufficiently charged and storage space available for transactions, cards can be read.

USB Charging Only Operation

When the reader is attached to a charger via a USB cable (not attached to a USB host), it has the same capabilities as in Standalone Operation plus the battery is charged.

USB Operation

When the reader is attached to a computer via a USB cable, it has the same capabilities as in USB Charging Only Operation plus the ability to communicate with the hosting computer. Any time the host puts the reader into suspend mode, the LED will turn off. Once the host takes the reader out of suspend mode, the LED will indicate the battery state.

Battery Charging

Battery charging is initiated at the start of USB Charging Only Operation and at the start of USB Operation. When battery charging is initiated, the voltage level of the battery is indicated via the LED. If the battery is fully charged, the LED will be solid amber. If the battery is not fully charged, the LED will blink amber very slowly.

Card Reading

Card reading may be initiated from any of the operational modes (Standalone, USB Charging Only, or USB). Card reading is initiated by pressing the button while the reader is powered off or while charging the battery.

When card reading is initiated, the level of the battery is tested and the LED will indicate the state of the battery and of card reading operations:

1. If the battery has sufficient charge to perform this card read and several more, the LED changes to green indicating the reader is ready for a card swipe and the Activity Timer is set.

Flash MagneSafe Swipe Reader

2. If the battery has enough charge to perform this card read but is low, the LED changes to solid red for about two seconds, followed by green indicating the reader is ready for a card swipe. It would be a good idea to charge the battery soon.
3. If the battery does not have enough charge to perform this card read, or there is no room to store the transaction (reader full), or the reader has run out of DUKPT keys, the LED blinks red quickly for three seconds and the reader reverts to power off or battery charging state (if connected to USB power). If the reader is not being powered through the USB cable, the User Switch is disabled until the reader is powered through the USB cable; the reader will not operate again until it is charged.

When the LED goes green and a user swipes a card, the LED goes off briefly while the reader decodes the card swipe, then the LED goes green to indicate a good swipe or red to indicate a bad swipe.

When the card swipe was good, the LED goes solid green for about two seconds, then the reader reverts to power off or battery charging state (if connected to USB power).

When the card swipe results in an error, the LED goes solid red for two seconds and then reverts to green indicating that the reader is ready for another attempt at card reading. The Activity Timer is set to its maximum value.

When the LED goes green and the reader is waiting for a swipe, if the Activity Timer expires, the reader reverts to power off or battery charging state (if connected to USB power).

When the LED goes green and the reader is waiting for a card swipe, if the battery charge goes too low to continue with this read, the LED blinks red quickly for three seconds and the reader reverts to power off or battery charging state (if connected to USB power). The reader must be charged before reading cards again.

CARD READ

A card may be swiped through the reader slot when the LED is solid green. The magnetic stripe must face toward the LED and may be swiped in either direction. If there is data encoded on the card, the reader will attempt to read the data, encrypt it, and then store it. If no errors were found while decoding the card data, the reader will automatically turn off.

READER STATES

The reader tracks its operational state. The application may retrieve the state at any time using the Get Reader State Command.

For convenience, this manual refers to states with the notation State:Antecedent (e.g., WaitActAuth:BadSwipe). State definitions can be found at the definition of the Get Reader State Command.

In most cases, the application could also track the state by inference. As the application interacts with a reader, most state transitions are marked by the commands and responses exchanged with the reader.

Examples of Host/Application/Reader interaction and state transitions:

Example 1 – Power Up, then user swipes a card successfully.

1. Reader Waiting (State = WaitSwipe:PU). This is after a Power Up.
2. User swipes card successfully
3. Reader Waiting (State = WaitSwipe:GoodSwipe).

Example 2 – Power UP, then user swipes a card incorrectly.

1. Reader Waiting (State = WaitSwipe:PU). This is after a Power Up.
2. User swipes card incorrectly
3. Reader Waiting (State = WaitSwipe:BadSwipe).

CHARGING THE READER BATTERY

As mentioned above (LED Indicator), the Flash reader may indicate low battery at power up by showing red for two seconds then turn solid green. The first time this happens, there will probably be sufficient battery available for several more card swipes, but the battery should be charged soon. If the low battery warning is ignored and the battery gets too low, the reader will refuse to power up until it has been charged.

Charge the reader by connecting it to any USB port on a running system or a compatible 5VDC source. For best results, allow the battery to charge fully (until the LED goes to steady amber) before using the reader again.