

MOTORIZED IntelliCoder USB/RS-232 DESKTOP READER-ENCODER TECHNICAL REFERENCE MANUAL

Manual Part Number 99875276-3

AUGUST 2007

MAGTEK[®]

REGISTERED TO ISO 9001:2000

1710 Apollo Court

Seal Beach, CA 90740

Phone: (562) 546-6400

FAX: (562) 546-6301

Technical Support: (651) 415-6800

www.magtek.com

Information in this document is subject to change without notice. No part of this document may be reproduced or transmitted in any form or by any means, electronic or mechanical, for any purpose, without the express written permission of MagTek, Inc.

MagTek is a registered trademark of MagTek, Inc.
IntelliStripe is a registered trademark of MagTek, Inc.
IntelliCoder is a trademark of MagTek, Inc.

REVISIONS

Rev Number	Date	Notes
1	16 Oct 03	Initial Release
2	5 Nov 03	Sec 1, Configurations: clarified power supply description; Features: removed JIS, to optional SAM and TRSM added "contact for further info"; clarified Rotary Pulse Generator; Removed descriptions of TRSM, Sam Ranch PCB, Power-on LED, Access to SAM Ranch sockets; Specifications: changed card speed to 7-10 ips. Sec 2, Figures 2-4 and 2-5: changed part number for power cord and changed voltage from 100-240 to 110V. Sec 3: deleted Figs 3-4, 3-5, 3-6, 3-7, and 3-8 and related text for SAM Ranch.
3	22 Aug 07	Added Encode Coercivity Ranges to specifications to show HiCo encode capability for 2750 Oe



REGISTERED TO ISO 9001:2000

MagTek Part Number 99875276-1
1710 Apollo Court, Seal Beach, CA 90740
Voice: 562-546-6400 Fax: 562-546-6301

25 February 2003

SOFTWARE LICENSE AGREEMENT

IMPORTANT: YOU SHOULD CAREFULLY READ ALL THE TERMS, CONDITIONS AND RESTRICTIONS OF THIS LICENSE AGREEMENT BEFORE INSTALLING THE SOFTWARE PACKAGE. YOUR INSTALLATION OF THE SOFTWARE PACKAGE PRESUMES YOUR ACCEPTANCE OF THE TERMS, CONDITIONS, AND RESTRICTIONS CONTAINED IN THIS AGREEMENT. IF YOU DO NOT AGREE WITH THESE TERMS, CONDITIONS, AND RESTRICTIONS, PROMPTLY RETURN THE SOFTWARE PACKAGE AND ASSOCIATED DOCUMENTATION TO ABOVE ADDRESS ATTENTION: CUSTOMER SUPPORT.

TERMS, CONDITIONS AND RESTRICTIONS

MagTek, Incorporated (the "Licensor") owns and has the right to distribute the described software and documentation, collectively referred to as the "Software".

LICENSE: Licensor grants you (the "Licensee") the right to use the Software in conjunction with MagTek products.

LICENSEE MAY NOT COPY, MODIFY OR TRANSFER THE SOFTWARE IN WHOLE OR IN PART EXCEPT AS EXPRESSLY PROVIDED IN THIS AGREEMENT. Licensee may not decompile, disassemble or in any other manner attempt to reverse engineer the Software. Licensee shall not tamper with, bypass or alter any security features of the software or attempt to do so.

TRANSFER: Licensee may not transfer the Software or license to the Software to another party without prior written authorization of the Licensor. If Licensee transfers the Software without authorization, all rights granted under this Agreement are automatically terminated.

COPYRIGHT: The Software is copyrighted. Licensee may not copy the Software except for archival purposes or to load for execution purposes. All other copies of the Software are in violation of this Agreement.

TERM: This Agreement is in effect as long as Licensee continues the use of the Software. The Licensor also reserves the right to terminate this Agreement if Licensee fails to comply with any of the terms, conditions or restrictions contained herein. Should Licensor terminate this Agreement due to Licensee's failure to comply, Licensee agrees to return the Software to Licensor. Receipt of returned Software by the Licensor shall mark the termination.

LIMITED WARRANTY: Licensor warrants to the Licensee that the disk(s) or other media on which the Software is recorded to be free from defects in material or workmanship under normal use. THE SOFTWARE IS PROVIDED AS IS WITHOUT WARRANTY OF ANY KIND, EITHER EXPRESS OR IMPLIED, INCLUDING, BUT NOT LIMITED TO, THE IMPLIED WARRANTIES OF MERCHANTABILITY AND FITNESS FOR A PARTICULAR PURPOSE. Because of the diversity of conditions and PC hardware under which the Software may be used, Licensor does not warrant that the Software will meet Licensee specifications or that the operation of the Software will be uninterrupted or free of errors.

IN NO EVENT WILL LICENSOR BE LIABLE FOR ANY DAMAGES, INCLUDING ANY LOST PROFITS, LOST SAVINGS OR OTHER INCIDENTAL OR CONSEQUENTIAL DAMAGES ARISING OUT OF THE USE OR INABILITY TO USE THE SOFTWARE. Licensee's sole remedy in the event of a defect in material or workmanship is expressly limited to replacement of the Software disk(s) if applicable.

GOVERNING LAW: If any provision of this Agreement is found to be unlawful, void or unenforceable, that provision shall be removed from consideration under this Agreement and will not affect the enforceability of any of the remaining provisions. This Agreement shall be governed by the laws of the State of California and shall insure to the benefit of MagTek, Incorporated, its successors or assigns.

ACKNOWLEDGMENT: LICENSEE ACKNOWLEDGES THAT HE HAS READ THIS AGREEMENT, UNDERSTANDS ALL OF ITS TERMS, CONDITIONS AND RESTRICTIONS AND AGREES TO BE BOUND BY THEM. LICENSEE ALSO AGREES THAT THIS AGREEMENT SUPERSEDES ANY AND ALL, VERBAL AND WRITTEN, COMMUNICATIONS BETWEEN LICENSOR AND LICENSEE OR THEIR ASSIGNS RELATING TO THE SUBJECT MATTER OF THIS AGREEMENT. QUESTIONS REGARDING THIS AGREEMENT SHOULD BE ADDRESSED IN WRITING TO MAGTEK, INCORPORATED, ATTENTION: CUSTOMER SUPPORT, AT THE ABOVE ADDRESS OR E-MAILED TO support@magtek.com

Limited Warranty

MagTek, Inc. warrants that the Product described in this document is free of defects in materials and workmanship for a period of one year from the date of purchase where the date of purchase is defined as the date of shipment from MagTek. During this warranty period, MagTek shall, at their option, repair or replace without charge for either parts or labor, any failure, malfunction, defect or nonconformity which prevents the product from performing in accordance with MagTek's published technical specifications and manuals.

This warranty does not apply to wear of the magnetic read head. This warranty shall not apply if the product is modified, tampered with, or subject to abnormal working conditions. This warranty does not apply when the malfunction results from the use of the Product in conjunction with ancillary or peripheral equipment where it is determined by MagTek that there is no fault in the Product itself.

Notification by the Customer to MagTek of any condition described above should be directed to the Customer's MagTek Sales Representative or to MagTek's Help Desk at (888) 624-8350. If the Product is to be returned from the Customer to MagTek, a returned material authorization (RMA) will be issued by MagTek. The Customer shall be responsible for shipping charges to MagTek, (1710 Apollo Court, Seal Beach, CA 90740). MagTek shall be responsible for shipping charges back to the Customer.

Repair or replacement as provided under this warranty is the exclusive remedy. This warranty is in lieu of all other warranties, express or implied.

FCC WARNING STATEMENT

This equipment has been tested and found to comply with the limits for a Class A digital device, pursuant to Part 15 of FCC Rules. These limits are designed to provide reasonable protection against harmful interference when the equipment is operated in a commercial environment. This equipment generates, uses, and can radiate radio frequency energy and, if not installed and used in accordance with the instruction manual, may cause harmful interference to radio communications. Operation of this equipment in a residential area is likely to cause harmful interference in which case the user will be required to correct the interference at his own expense.

FCC COMPLIANCE STATEMENT

This device complies with Part 15 Of The FCC Rules. Operation of this device is subject to the following two conditions: (1) This device may not cause harmful interference. And (2) This device must accept any interference received, including interference that may cause undesired operation.

CANADIAN DOC STATEMENT

This digital apparatus does not exceed the Class A limits for radio noise for digital apparatus set out in the Radio Interference Regulations of the Canadian Department of Communications.

Le présent appareil numérique n'émet pas de bruits radioélectriques dépassant les limites applicables aux appareils numériques de la classe A prescrites dans le Règlement sur le brouillage radioélectrique édicté par le ministère des Communications du Canada.

UL/CSA

This product is recognized per Underwriter Laboratories and Canadian Underwriter Laboratories 1950.

TABLE OF CONTENTS

SECTION 1. FEATURES AND SPECIFICATIONS	1
CONFIGURATIONS	1
FEATURES	1
APPLICABLE DOCUMENTS	2
Standards	2
MagTek Documents	2
SOFTWARE ACCESSORIES	2
COMPONENTS	2
Motorized Card Transport	3
Lead-in Roller System	3
Front Opto-Sensor.....	3
Encode Opto-Sensor	3
Card-Landed Mechanical Switch Sensor	3
Spring-Loaded Card Registration Guide(s)	4
Ability To Transport 0.010 ” to 0.035” Cards	4
Card Entry/Orientation.....	4
Magstripe Read/Encode	4
SmartCard	5
Packing/Enclosure.....	5
Small Footprint	5
Cable Management	6
Jam Clearance – Ejector Rod.....	6
Access to Optional SAMs.....	6
Tamper Resistant Security Module (TRSM), Optional	6
Electronics and PCBs.....	6
Main PCB Components	6
Host Serial Port.....	7
USB Port.....	7
Auxiliary Serial Port	7
Power Input.....	7
Polarization and Securement of Serial Port Cables.....	7
Opto-Sensor Inputs	8
Rotary Pulse Generator	8
External SAM Ranch Interface, Optional	8
Dual Color LED.....	8
ISO-8 Smartcard Connector with Landing Switch	8
3-Track Read/Encode Magnetic Head	8
DC Motor.....	8
Microcontroller LED Indicator	8
External Auto-Ranging Power Pac.....	9
Auto-Ranging Input	9
Output Rating.....	9
Firmware.....	9
Memory Cards	9
FLASH Download Protection.....	9

SPECIFICATIONS.....	10
SECTION 2. INSTALLATION.....	11
MOUNTING	11
Footpad Mounting	11
Mounting Hole Screws	11
Lock-in-place-slots	11
Flange.....	11
MagTek Mounting Plate	11
REAR PANEL AND CABLE CONNECTIONS.....	12
SECTION 3. OPERATION AND MAINTENANCE.....	19
OPERATION	19
PREVENTIVE MAINTENANCE	19
CORRECTIVE MAINTENANCE.....	19
Ejector Rod for Card Jams	19
APPENDIX A. DIMENSIONS FOR MOUNTING.....	21
MOUNTING	21
Footpad Mounting	21
Mounting Hole Screws	21
Lock-in-place-slots	21
Flange.....	21

TABLES OF FIGURES

Figure 1-1. Motorized IntelliCoder-----	viii
Figure 2-1. Dimensions for Mounting Holes for 3-Screw Set and Foot Pads-----	12
Figure 2-2. Dimensions for Mounting Holes for Lock-in-Place Slots-----	12
Figure 2-3. Rear Panel and Cover -----	13
Figure 2-4. Cable Connections – RS-232-----	14
Figure 2-5. Cable Connections - USB-----	15
Figure 2-6. Rear Panel Cover Replaced – RS-232 Connection -----	16
Figure 2-7. Rear Panel Cover Replaced – USB Connection -----	17
Figure 3-1. Card Orientation-----	19
Figure 3-2. Ejector Rod Removal from Storage -----	20
Figure 3-3. Card Removal -----	20
Figure A-1. Mounting Dimensions 1 -----	22
Figure A-2. Mounting Dimensions 2 -----	23
Figure A-3. MagTek Mounting Plate, 1 -----	24
Figure A-4. MagTek Mounting Plate, 2 -----	25

TABLES

Table 1.1. Specifications -----	10
Table 2-1. Pin List for Motorized IntelliCoder to Host PC Cable P/N 16051417 -----	14
Table 2-2. Cable Connections – USB Signal-----	15
Table 2-3. Cable Connections – USB Power-----	16

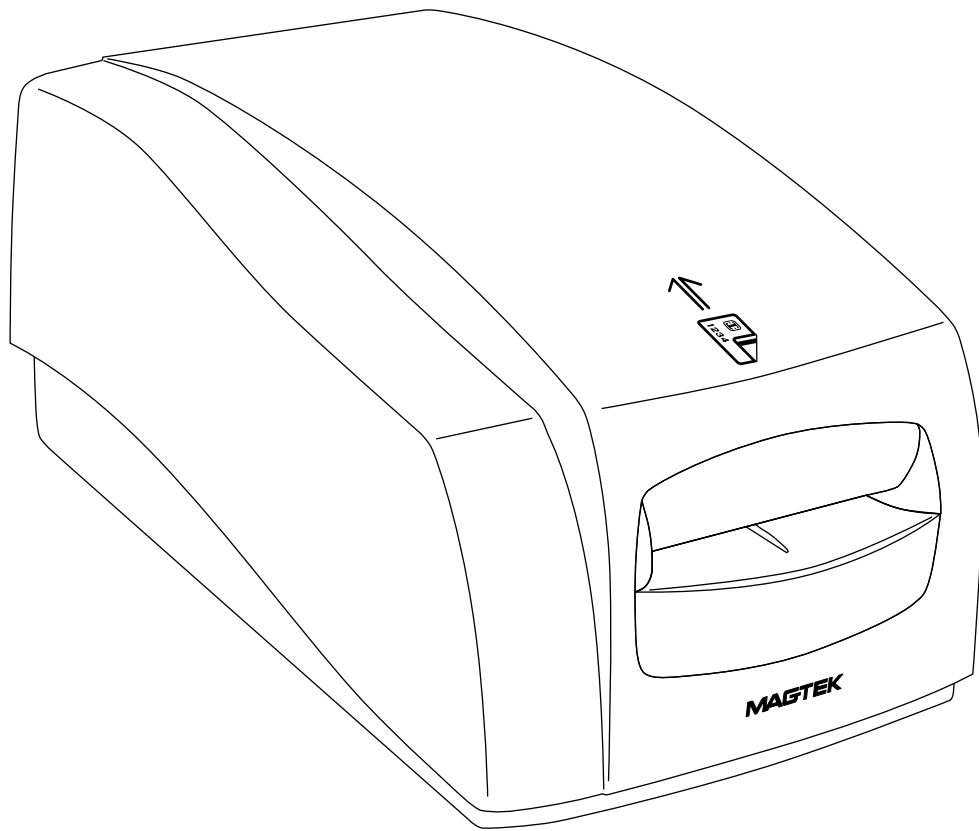

Figure 1-1. Motorized IntelliCoder

SECTION 1. FEATURES AND SPECIFICATIONS

The Motorized IntelliCoder™ reads and encodes magnetic-stripe cards and smartcards. It operates with the IntelliCAT Software Suite.

CONFIGURATIONS

Part numbers and descriptions for the basic configuration are as follows:

16050409	Motorized IntelliCoder – Mag-stripe and Smartcard
16050411	Motorized IntelliCoder – Mag-stripe only
16051417	I/O Cable, 10-pin RJ45 connector connects to host 9-pin connector with 12V/Ground connector for Power Supply.
16051422	USB Cable, 5-pin mini B plug, connects to host 4-pin USB Type A Plug with the 10-pin RJ45 and 12V/Ground connector for Power Supply
64300091	Power Supply 12 VDC, 4 A output, 100 –240 VAC auto ranging input.
71100001	AC power cord, P/N is for use in North America. Other users must supply their own cord, or contact MagTek for international cords.

FEATURES

The Motorized IntelliCoder provides the following key features:

- 3-Track magstripe read and encode with support for HiCo and LoCo cards. Also supports Drivers License, and Custom format encode scheme.
- EMV T=0, T=1 Smartcard Interface. Also supports popular memory cards.
- Optional support for 6-socket SAM Ranch using a piggyback PCB.
- RS-232 or USB primary host interface using MCP protocol.
- Auxiliary RS-232 interface to support an external interface.
- Small and attractive desktop enclosure with easy access to Optional SAM(s). Also provides facilities for cable strain-relief and card-jam clearing.
- FLASH programmable
- Dual Color LED status indicator.
- Single cable with remote power pack. Power is routed through communications cable.
- Optional Tamper Switch

APPLICABLE DOCUMENTS

Standards

ISO 7811-2, -3, -4, -5	Identification cards tracks 1-3
ISO 7810	Physical specifications
ISO 7816	Smartcard specifications
ISO 9564	Requirements for Offline PIN and TRSM
EMV 1996	Europay-Mastercard-Visa 1996 Level I Specification
EMV 2000	Europay-Mastercard-Visa 2000 Level I Specification

MagTek Documents

IntelliCAT System Installation and Operation Manual, P/N 99875169
MCP Serial Transport Protocol, P/N 99875163

SOFTWARE ACCESSORIES

The following Software Modules may be required and will assist in the development of application software. In addition, this software can provide an initial test platform for checkout of the Motorized IntelliCoder.

- IntelliStripe Picture Demo with MCP Driver:
P/N 30037472 (CD) or P/N 99510015 (Web Release)
This software will install both a Demo program and the MCP driver.
The Demo program is useful for initial checkout of the Reader's functionality. The MCP driver is recommended for use as the communications interface on Windows based host systems. Application programmers can interface to the MCP driver via a MagTek defined API.
- Source Code for Picture Demo Program:
P/N 30037436
Visual Basic 6.0 source code for the Picture Demo program.
This will be useful to Application Programmers, as it shows examples of how to interface with the MCP drivers and how to use the various commands.

COMPONENTS

The components are grouped in the following categories: The Motorized Card Transport, Packaging/Enclosure, and Electronics and PCB, Optional SAM Ranch PCB, External Auto-ranging Power Pack, and Firmware.

Motorized Card Transport

The Card Transport is based on an existing MagTek magstripe/encode module. This module incorporates the following features:

Lead-in Roller System

The primary purpose of the Lead-in Roller System is to grab the card from the user during card insertion and to make sure the card is mechanically under motor control before reaching the read/write head and its associated drive rollers.

As a secondary function, the Lead-in Drive Roller will also assist in allowing for a more reliable exit positioning of the card during an eject sequence. The Lead-in Roller allows for the possibility of pulling the card back into the reader if required.

Front Opto-Sensor

The Front Opto-Sensor is located near the entrance of the card path. The primary function of this sensor is to provide information that a card has been inserted into the Reader and to inform the microcontroller to initiate motor and card-handling activities.

As a secondary function, this sensor also provides feedback regarding card location during a card eject and/or jam-clear sequence.

Encode Opto-Sensor

This sensor is located approximately 0.300" before the crown of the magnetic read/write head. The primary purpose of this sensor is to provide the microcontroller with the position of the leading edge of the card just before encoding. This information, in conjunction with the Rotary Pulse Generator (RPG), allows for a higher degree of positional accuracy just before initiation of the magnetic encode process.

As a secondary function, this sensor also provides feedback regarding card location during a card-eject and/or jam-clear sequence.

Card-Landed Mechanical Switch Sensor

This switch is integrated as part of the ISO-8 smartcard contact block, and the sensor provides an indication when the leading edge of a card has reached physical travel limit for rearward travel and has successfully engaged with the smartcard contacts which allows for a successful smartcard interface session.

Spring-Loaded Card Registration Guide(s)

The spring-loaded guide ensures that the reference edge of the card is mechanically referenced to the magnetic read/write head, so that the magnetically encoded track data is physically located on the magstripe in accordance with the specifications of ISO 7811.

Ability To Transport 0.010" to 0.035" Cards

Cards that meet the ISO 7810 card thickness of 0.027" to 0.033" will work properly with both magnetic and smartcard elements of this system. However, card thickness of 0.010" to 0.035" should not be expected to work properly in regard to magnetic and smartcard operations. These cards only need be successfully transported without jamming in the Reader.

Card Entry/Orientation

Enter an ISO 7810-, 7811-, or 7816-compatible card into the Reader with the front surface of the card up (side with the embossed characters and smartcard IC) and visible to the user during insertion. The magstripe side of the card will face down and not be visible to the user during insertion. The magstripe will be towards the right side of the Reader (as viewed from the front).

Magstripe Read/Encode

The Transport reads and encodes a magnetic stripe card that meets the requirements of the ISO 7810 and 7811 specifications. In addition, the device provides support for a variety of user selectable data densities and data formats that fall within the boundaries of ISO 7810 and 7811.

Number of tracks: The magnetic encode section provides the ability to encode or read three tracks of magnetic data as specified in ISO 7810 and 7811 in a single physical pass of the card over the read/write head.

Note

*This does not imply that both read and encode functions occur simultaneously. It means that either a 3-track read **OR** a 3-track encode sequence occurs during a single pass of the card over the magnetic head.*

Direction of Magnetic Encode: To meet the requirements of ISO 7810 and 7811, the magstripe card is encoded in a unidirectional movement, which starts at the defined leading edge and continues toward the trailing edge of the card; this means that the card is encoded as the card is moved from the front entrance of the Reader towards the rear of the Reader.

Direction of Magnetic Read: The ISO 7810 and 7811 specifications allow for bidirectional magnetic reading of the card. As such, the Reader provides services that allow the card to be read in either direction.

Read Formats: In addition to reading cards that meet the ISO 7810 and 7811 specifications, the Reader reads AAMVA drivers license cards. Also, all 3 tracks of the Reader reads any card that follows ISO 5-bit or 7-bit data formats and is within any bit density in the range of 75 to 210 bpi.

Encoded Formats: In addition to encoding cards that comply with ISO 7811 encoding formats, it is possible to customize encoding formats as follows:

- Encoded bit density is selectable at 75 or 210 bpi on all three tracks.
- The character is selectable for either 5-bit or 7-bit format on all three tracks.
- The Start-Sentinel character is user selectable as either a (;) or a (=) for 5-bit code or a (%) or (=) for 7-bit code.

SmartCard

The transport provides smartcard contacts that are compatible with ISO 7816 and EMV level 1 Standards. In addition, the smartcard contact block has a card landed switch that detects when an ISO 7810 thickness card is properly pressed against the smartcard contact block.

Packing/Enclosure

The enclosure provides for proper functionality for user interface, cable routing, mechanical mounting, jam clearance, optional SAM (Security Access Module) installation and Optional TRSM (Tamper Resistant Security Module), and general maintenance.

Small Footprint

The unit has the smallest footprint required by the limited counter-top and desktop space available at financial institutions.

Cable Management

The following provisions are made for communication and power lines:

- Polarization and locking of cable connectors
- Strain relief of cables
- Wire routing functionality
- RJ series connectors for main and auxiliary RS-232 interfaces.
- Power is brought to the unit through the main RS-232 cable
- Power-pack is away from the unit and will attach to the main RS-232 cable

Jam Clearance – Ejector Rod

For easy removal of a jammed card, an ejector rod is accessible at the rear of the unit. To clear a jam, the ejector rod is removed from the rear of the unit and inserted into an access hole on the back panel of the reader to push a card out of the front slot of the unit.

Access to Optional SAMs

The unit provides quick and easy access to the optional SAM ranch (a PCB with 6 optional SAM modules) through an access hatch at the base of the unit. Contact MagTek for further information regarding optional SAM module. Contact MagTek for further information regarding optional SAM Module.

Tamper Resistant Security Module (TRSM), Optional

The unit provides mechanical and electromechanical features that allow the enclosure to be used within a TRSM environment per ISO 9564. Mechanical features visually indicate intrusion into the enclosure, and electromechanical switches on the Main PCB signal that the mechanical enclosure had been opened. This allows the electronics to erase the keys in its memory area whether the unit is powered or not. Contact MagTek for further information regarding optional TRSM.

Electronics and PCBs

The core electronic functions of the unit reside on a single PCB referred to as the Main PCB. As an option, a second PCB referred to as the SAM Ranch may be plugged into the Main PCB.

Main PCB Components

The Main PCB Components are the microcontroller, RAM space, and ROM space.

Microcontroller: The main PCB is based upon a Philips XAS3 microcontroller. This controller was used on previous MagTek products with previously developed firmware.

RAM Space: 40 K bytes

ROM Space: ROM Flash:

Main Program Memory: 512 K Bytes

Boot Loader Memory: 24 K Bytes

Configuration Memory: 8 K Bytes

Host Serial Port

The RS-232 Host Serial Port provides serial communications between the Reader/Encoder and the Host Computer. In addition, the Host Serial Port carries DC power from the remote power pack to the Reader/Encoder. The Host Serial Port is capable of communication speeds of up to 115 K bits/sec.

USB Port

The Host USB 1.1 Port provides communications between the Reader/Encoder and the Host Computer. The USB Cable, 5-pin mini B Plug, connects to host 4-pin USB Type A Plug, with 10-pin RJ45 and 12V/Ground connector for Power Supply.

Auxiliary Serial Port

The Auxiliary Serial Port provides serial communications and power between the Reader/Encoder and an external device. The Auxiliary Serial Port is capable of communication speeds of up to 19.2 Kbits/sec. The port is also capable of carrying +12 VDC at up to 1 A for a device connected to this port.

Power Input

The Reader/Encoder is powered by a 12 VDC power-pack. The +12 VDC power is carried to the Reader/Encoder as part of the Host Serial cable.

All other voltages required by the Main PCB are generated onboard as required.

The input connector and cabling carry power to support the Reader/Encoder.

Polarization and Securement of Serial Port Cables

The ports, located at the rear of the Reader/Encoder, use RJ connectors with locking tabs, which assist in securing the cable to the Reader/Encoder.

Opto-Sensor Inputs

The Main PCB provides inputs for the three opto-sensors (Front, Encode, and Rear).

Rotary Pulse Generator

The Main PCB provides input for the MagTek 75/210 bpi Rotary Pulse Generator (RPG).

External SAM Ranch Interface, Optional

The Main PCB provides resources for interconnect, securement, and power of an optional SAM Ranch PCB. The optional SAM Ranch PCB is accessed from the hatch door at the bottom of the Encoder/Reader.

Dual Color LED

The Main PCB provides facilities for a dual color, red/green PCB. The LED is located on the front bezel of the Encoder/Reader. When the unit is powered up, the LED will blink green or red until the Host commands it to a different state. Green means the unit is ready for normal operation. Red means a card is jammed in the unit and should be manually removed.

ISO-8 Smartcard Connector with Landing Switch

The Main PCB provides resources to support an interface with an ISO-8 smartcard connector with its associated landing switch. The electronics meet EMV Level 1 requirements.

3-Track Read/Encode Magnetic Head

The Main PCB supports an interface to a 3-Track Read/Encode Magnetic Head. A flex-cable circuit connects the magnetic head to the Main PCB.

DC Motor

The Main PCB supports a bidirectional drive interface to a DC motor. The motor drives the card in the forward and reverse directions in the transport. The motor can also be driven with a small “holding” current to keep a card positioned over the Smart Card contact block during a Smart Card session.

Microcontroller LED Indicator

The Main PCB supports a “watchdog” LED, which blinks on and off providing visual indication that the microcontroller is in a normal state of operation. The LED can be viewed when the bottom access hatch is removed from the enclosure.

External Auto-Ranging Power Pac

The Reader/Encoder is powered from an external power-pack, which is located near the Host Computer System. Power is routed to the Reader/Encoder through the Host RS-232 cable.

Auto-Ranging Input

The external power pack features an Auto-ranging AC input that allows for direct connection to either a 100 VAC or 220 VAC, 50 to 60 Hz.

Output Rating

The power pack is rated at approximately +12 VDC @ 4 A \pm 5%.

Firmware

The firmware for the Reader/Encoder is based upon existing MCP protocol and command set.

Memory Cards

The firmware supports smartcard interfaces to memory cards.

FLASH Download Protection

To prevent illegal applications from being downloaded into the Reader/Encoder, the firmware verifies that the downloaded FLASH program is provided (authorized) by MagTek. If the program cannot ID itself correctly, the boot loader program abandons the FLASH load sequence and returns a unique status code that identifies the situation to the Host.

SPECIFICATIONS

The Specifications are listed in Table 1-1.

Table 1.1. Specifications

OPERATING	
MSR Read-data Format Specifications Supported	Mag-Stripe: ANSI/ISO 7810, 7811 /AAMVA for tracks 1, 2, and 3 Smart Card: ISO 7816-1, -2, and -3
Encode Coercivity Ranges	LoCo = 325 Oe +/- 75 Oe (Range of 250 Oe to 400 Oe) HiCo = 2750 Oe +/- 500 Oe (Range of 2250 Oe to 3250 Oe)
Input Voltage	+12 VDC ±5%
Current Draw	Idle: 300 mA Max: 3.0 A (during HiCo encode sequence) and 1 A draw from an Auxiliary Serial Port Device.
MTBF	Electronics: 125, 000 hours Magnetic Read Head: 1 million passes (500,000 insertion cycles) Smartcard contacts: 1 million transactions
Card Speed	7-11 ips
Interface	RS-232, USB
MECHANICAL	
Dimensions	
Length	8.440" (includes Mounting Flange) (211.008 mm)
Width	4.470" (111.754 mm)
Height	3.85" (includes Mounting Flange) (97.79 mm)
Weight	2.0 lb (0.9072 Kg)
ENVIRONMENTAL	
Temperature	
Operating	41 °F to 113 °F (5 °C to 45 °C)
Storage	-40 °F to 158 °F (-40 °C to 70 °C)
Humidity	
Operating	5% to 95%
Storage	5% to 95% noncondensing
Altitude	
Operating	0-10,000 ft. (0-3,048 m.)
Storage	0-10,000 ft. (0-3,048 m.)

SECTION 2. INSTALLATION

The installation of the Motorized IntelliCoder consists of mounting the unit on a flat surface, connecting the I/O RS-232 cable to the host serial port, and the Power Supply to the I/O cable and to a wall receptacle.

MOUNTING

The bottom of the unit is shown in Figures 2-1 and 2-2. The Motorized IntelliCoder may be mounted in one of three ways: 1) foot pads, 2) set of mounting holes for 3 screws (4 x 40), and 3) 4 lock-in-place slots.

Footpad Mounting

The footpads are mounted at the factory. Simply place the unit on a level surface with approximately 4 inches clearance from obstructions at the front of the unit for card clearance. Leave enough room at the rear of the unit for cable clearance.

Mounting Hole Screws

Locate the 3 screw holes (4 x 40 screws) shown in Figure 2-1. The length of the screws depends on the thickness of the mounting surface. Drill 3 holes in the mounting surface that match the set of screw holes. The screws are mounted from under the mounting surface and into the bottom of the Motorized IntelliCoder.

Lock-in-place-slots

Figure 2-2 shows the dimensions of the Lock-in-place slots. The holes next to the lock-in-place-slots are for inserts. The holes are placed over mounted inserts and the unit is pulled the length of the slots forcing the thickness of the bottom plate to lock the unit in place. Dimensions of the slots and inserts are shown in Appendix A.

Flange

The flange shown in the illustration may be used with any mounting configuration. The hole in the flange is for a #4 screw.

MagTek Mounting Plate

MagTek offers an optional mounting plate. The plate dimensions are shown in Appendix A, P/N 16054403.

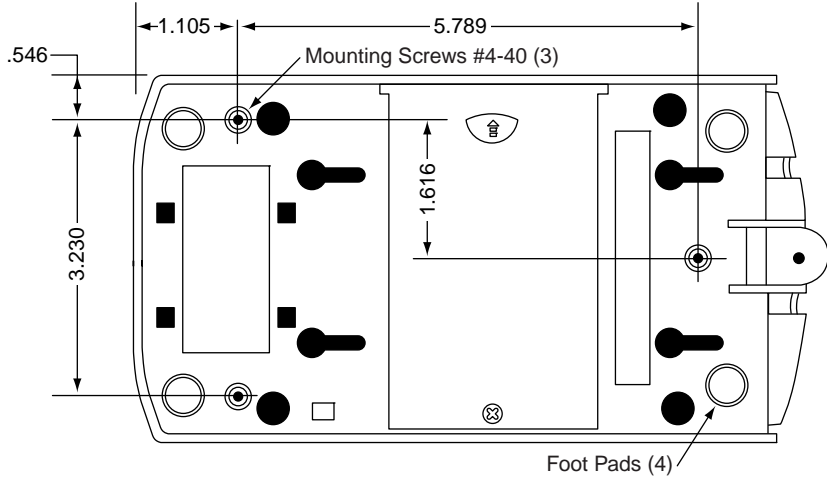

Figure 2-1. Dimensions for Mounting Holes for 3-Screw Set and Foot Pads

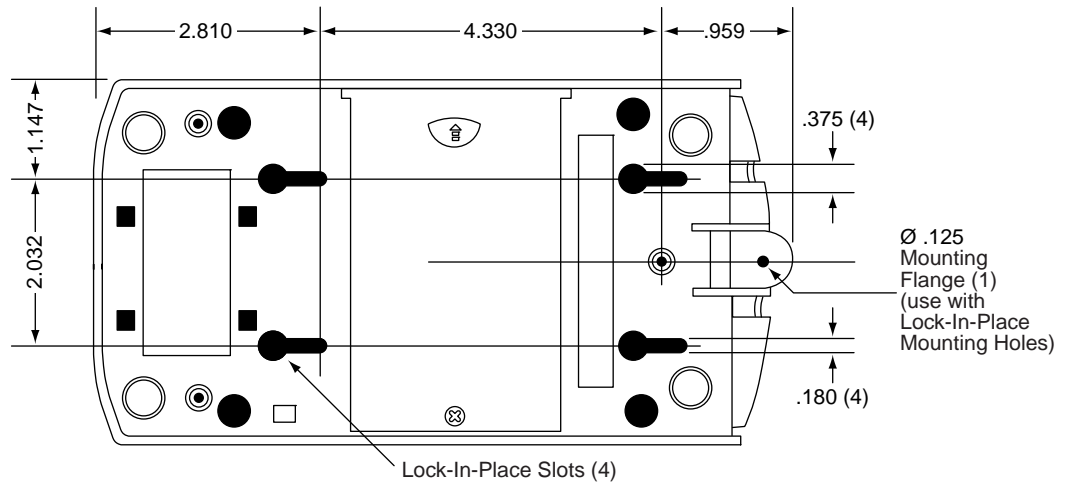

Figure 2-2. Dimensions for Mounting Holes for Lock-in-Place Slots

REAR PANEL AND CABLE CONNECTIONS

To access the rear panel and cable connections on the Motorized IntelliCoder, remove the rear panel cover, shown in Figure 2-3, by squeezing the top mounting clip on the cover as indicated in the illustration. To replace the back panel, insert the mounting clips into the guide slots and press into the attachment slots as indicated in the illustration.

Also shown in the illustration are the Auxiliary and the Host RS-232 and USB connectors. The ejector rod is used to remove jammed cards and is stored on the back panel as shown.

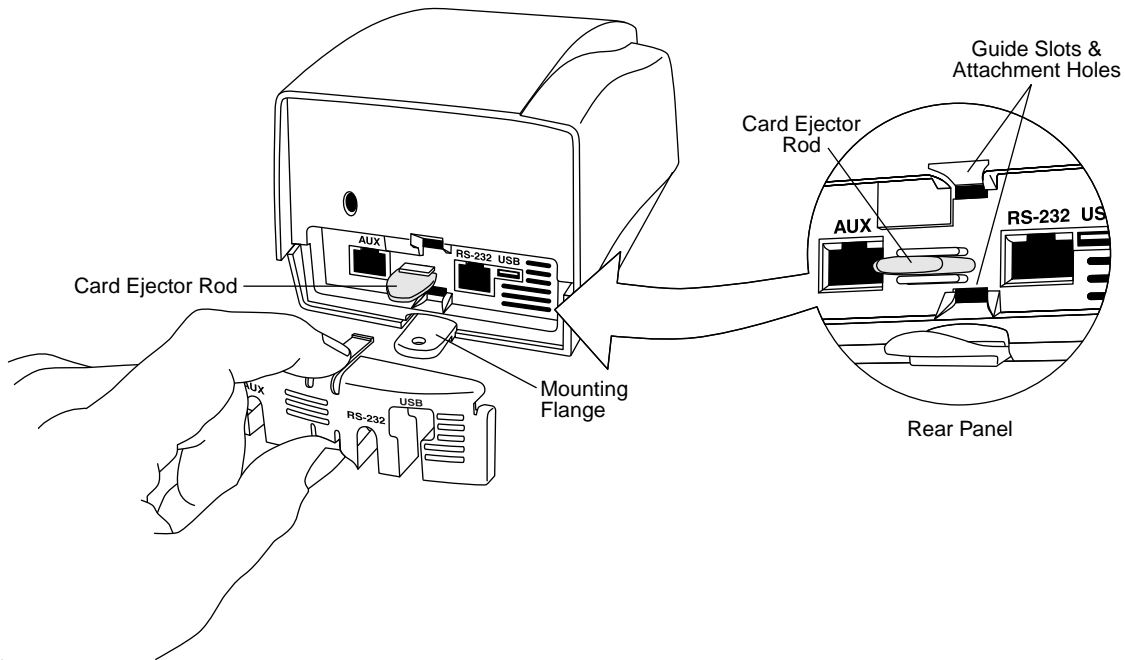

Figure 2-3. Rear Panel and Cover

Connect the Host PC cable (P/N 16051417) to the RS-232 connector on the Motorized IntelliCoder as shown in Figure 2-4 for the RS-232 connection.

Connect the Host PC Cable to the PC. Connect the Power Supply Cord (part of P/N 64300091) to the Host PC cable. Connect the North American 100-240v power cord (P/N 71100001) to the power supply.

Caution

Do not plug the power supply into a wall receptacle yet.

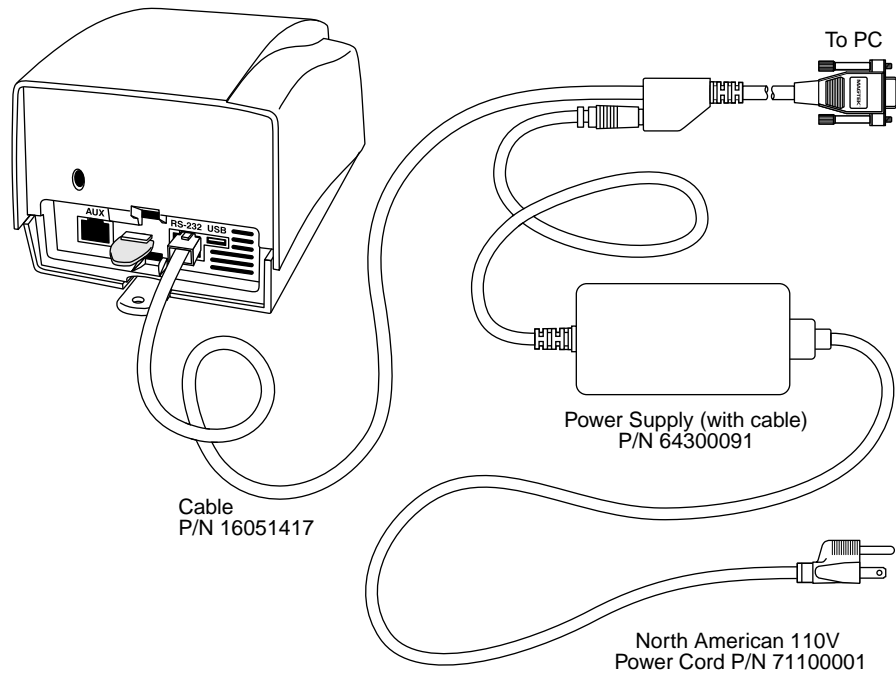

Figure 2-4. Cable Connections – RS-232

Table 2-1 lists the pins for the host cable P/N 16051417.

Table 2-1. Pin List for Motorized IntelliCoder to Host PC Cable P/N 16051417

10P10C RJ Plug		2.5MM POWER JACK		DB-9 Female	
1	PWR GND	SHELL	GND		
2	+12	CENTER PIN	+12		
3	TXD			2	RXD
4	CTS			7	RTS
5	SIG GND			5	GND
6	PWR GND	SHELL	GND		
7	RTS			8	CTS
8	+12	CENTER PIN	+12		
9	RXD			3	TXD
10	+12	CENTER PIN	+12		
				4	DTR
				6	DSR

Cable connections for the USB are shown in Figure 2-5, and the pin lists are shown in Table 2-2 and Table 2-3.

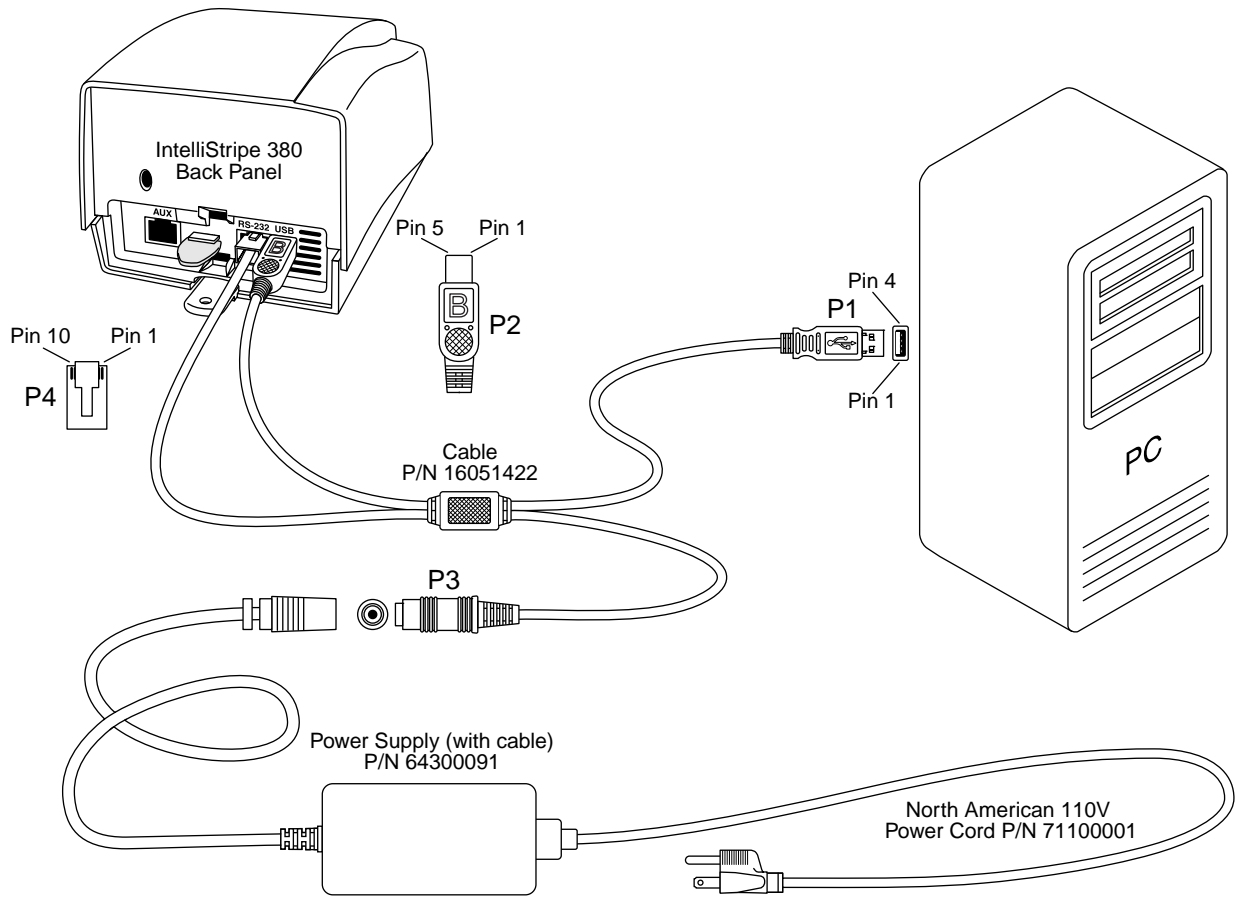

Figure 2-5. Cable Connections - USB

Table 2-2. Cable Connections – USB Signal

CONNECTOR WIRE			
P1 USB Type A Plug	Signal Name	Wire Color	P2 Mini USB Type B Plug
1	V Bus	Red	1
2	D-	White	2
3	D+	Green	3
4	Gnd	Black	5
Shell (Braid Shield)			Shell (Braid Shield)

Table 2-3. Cable Connections – USB Power

P3 – 2.5 mm Power Jack		Wire Color	P4 – 10P10C RJ Plug	
Shell	Gnd	Drain Wire	1	PWR GND
Center Pin	+12	26AWG Wire (Black)	2	+12
Shell	Gnd	Braid Shield	6	PWR GND
Center Pin	+12	26AWG Wire (Brown)	8	+12
Center Pin	+12	26AWG Wire (Red)	10	+12

Check all connectors to ensure they are properly connected. Replace the Rear Panel Cover by inserting the mounting clips into the guide slots and press into the attachment slots as indicated in Figure 2-3.

After connectors are checked and the Rear Panel Cover replaced, the unit should look similar to Figure 2-6 and 2-7.

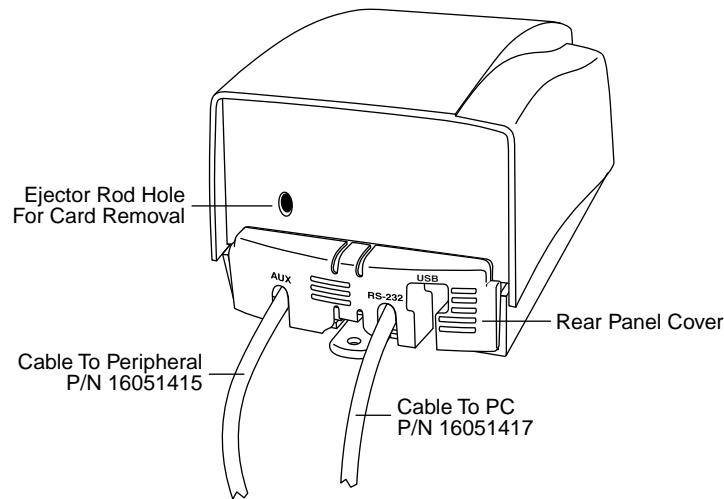

Figure 2-6. Rear Panel Cover Replaced – RS-232 Connection

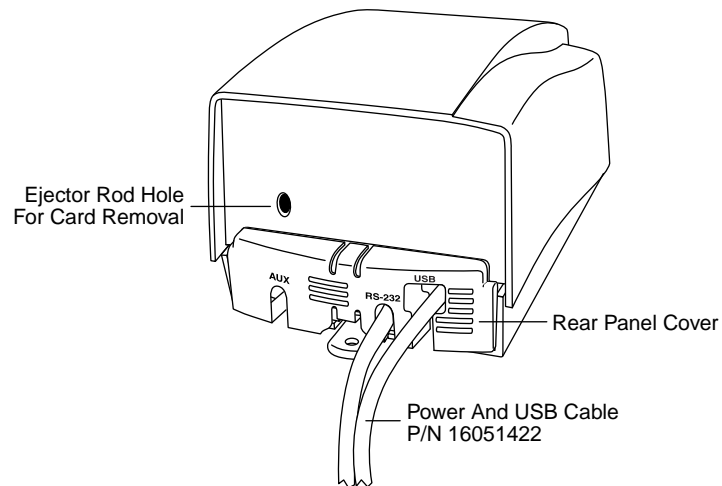

Figure 2-7. Rear Panel Cover Replaced – USB Connection

Plug in the power supply into a wall receptacle.

SECTION 3. OPERATION AND MAINTENANCE

The operation of the unit includes inserting and removing the card. Maintenance includes keeping the unit clean and removing jammed cards from the unit.

OPERATION

The card is inserted with the magnetic stripe down and to the right as illustrated in Figure 3-1. Perform any tasks on the PC as directed. The LED gives status or direction as defined by the PC Host Program.

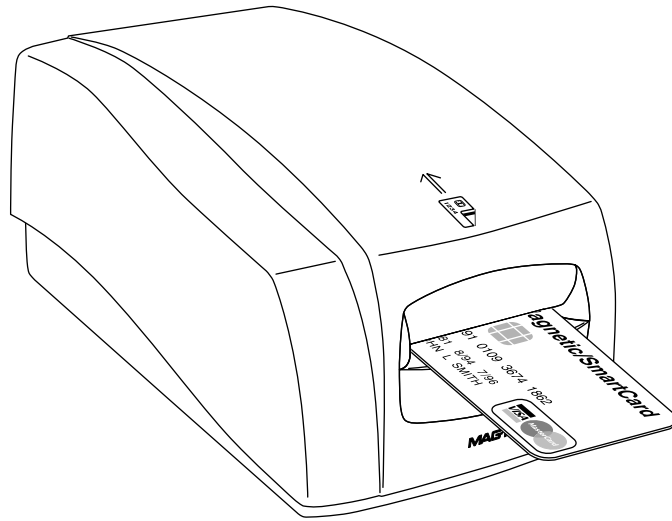

Figure 3-1. Card Orientation

PREVENTIVE MAINTENANCE

Preventive maintenance includes cleaning the unit periodically with a lint-free cloth. The cleaning schedule depends on how clean or dirty the environment is.

CORRECTIVE MAINTENANCE

Ejector Rod for Card Jams

Corrective maintenance includes removing the card in case of power failure or card jam. In most cases, resetting the unit will cause the card to automatically eject the card. To reset the unit unplug the Power Supply connector (Figure 2-4) from the I/O connector, wait 10 seconds, and plug it back in.

If the card does not automatically eject, the card may be pushed out with a special tool, the Ejector Rod, which is located in the Rear Panel of the unit, as shown in Figure 2-3.

Shut power off by unplugging the power supply (Figure 2-4), and remove the card with the Rod as follows:

1. Remove the Rear Panel Cover to access the Ejector Rod as indicated in Figure 3-2.

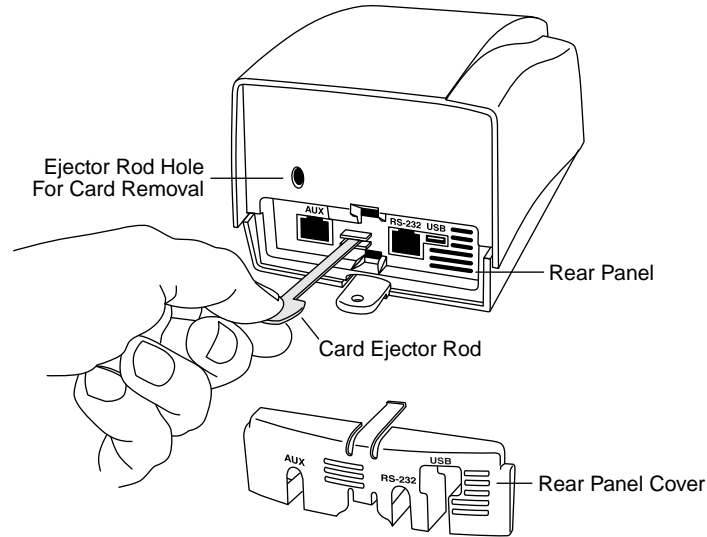

Figure 3-2. Ejector Rod Removal from Storage

2. Look into the Hole for Card Removal in the back of the unit, shown in Figure 3-2, to see the jammed card. This will indicate the approximate position where the notch on the Ejector Rod will be positioned with respect to the card.
3. Insert the Rod into the Hole for Card Removal, as shown in Figure 3-3 and push the Rod until the card appears in the slot at the front of the unit.

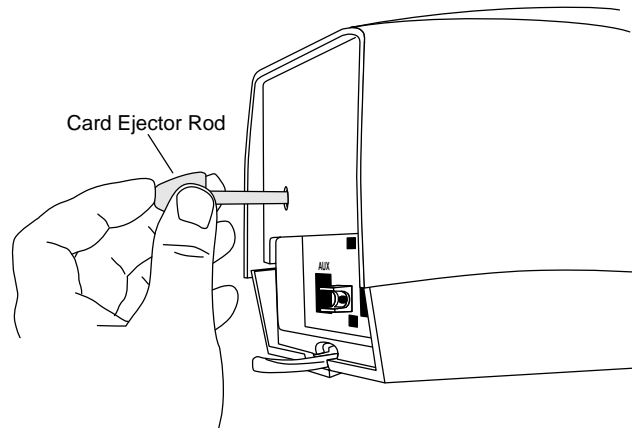

Figure 3-3. Card Removal

4. Manually remove the card when it appears in the slot in the front of the unit.
5. Reconnect the power cord.

APPENDIX A. DIMENSIONS FOR MOUNTING

MOUNTING

The bottom of the unit is shown in Figure 2-1 and 2-2. The Motorized IntelliCoder may be mounted in one of three ways: 1) foot pads, 2) set of mounting holes for 3 screws (4 x 40), and 3) 4 lock-in-place slots.

The mounting dimensions of the 3 screw holes and the 4 lock-in-place slots are shown in Figure A-1.

Footpad Mounting

The footpads are mounted at the factory if it is the default. Simply place the unit on a level surface with approximately 4 inches clearance from obstructions at the front of the unit for card clearance. Leave enough room at the rear of the unit for cable clearance.

Mounting Hole Screws

Locate the 3 screw holes (4 x 40 screws) shown in Figure 2-1. The length of the screws depends on the thickness of the mounting surface. Drill 3 holes in the mounting surface that match the set of screw holes. The screws are mounted from under the mounting surface and into the bottom of the Motorized IntelliCoder.

Lock-in-place-slots

The overall dimensions of the unit are shown in Figure A-2.

The MagTek Mounting Plate, Figures A-3 and A-4, show the use of the Lock-in-place slots (Refer also to Figures 2-2). In the example the holes are placed over mounted inserts and the unit is pulled the length of the slots forcing the thickest part of the plate to lock the unit in place. The value and tolerances of the plate at the end of the slots are $.087" \pm .005"$ (Figure A1), and the value and tolerances of the "stem" of the mushroom-shaped inserts are $.085" \pm .005"$ as shown in Figure A-4.

Flange

The flange shown in Figure 2-2 may be used to screw the unit to the mounting surface using a #4 screw. It can be used with any mounting configuration.

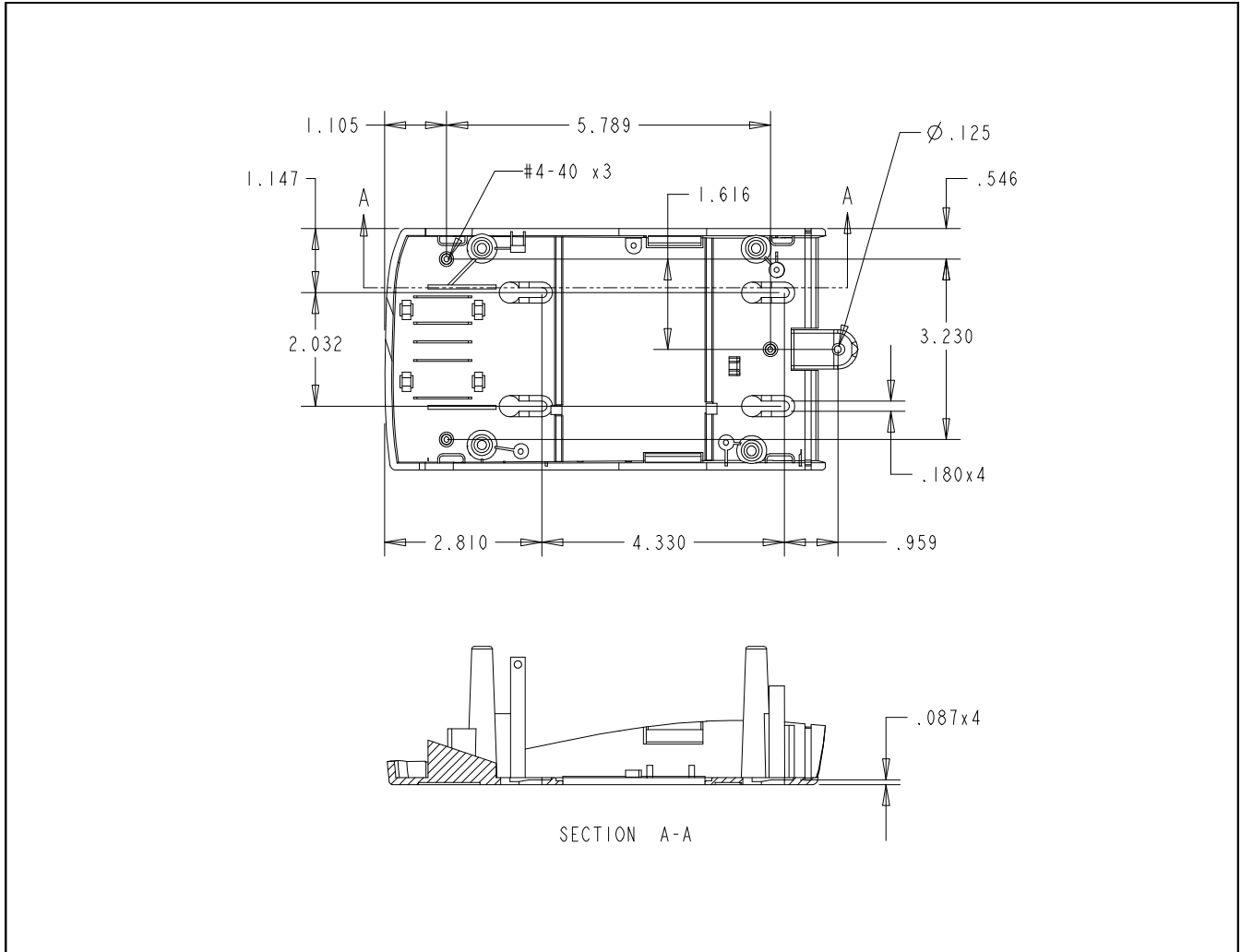

Figure A-1. Mounting Dimensions 1

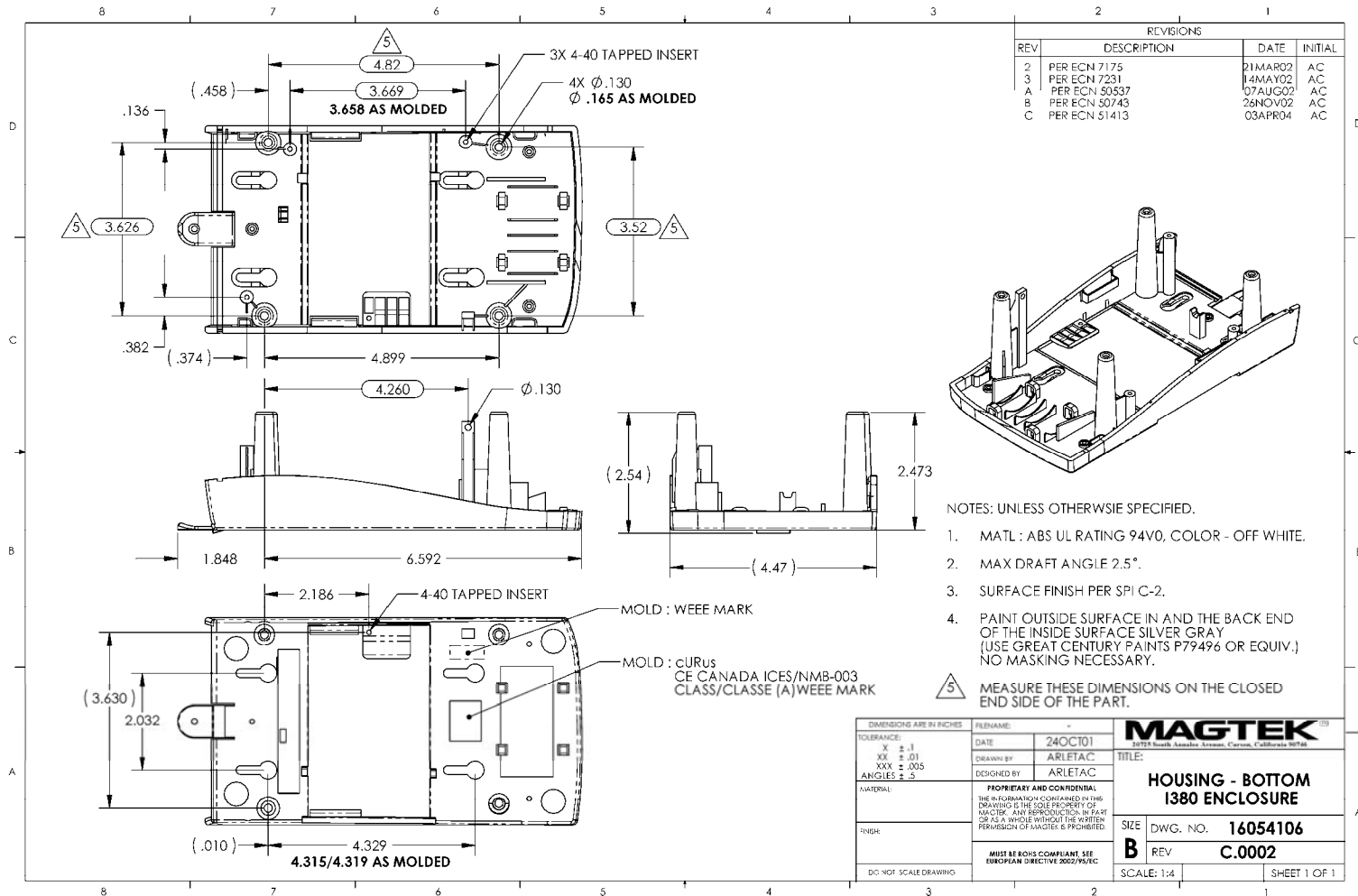

Figure A-2. Mounting Dimensions 2

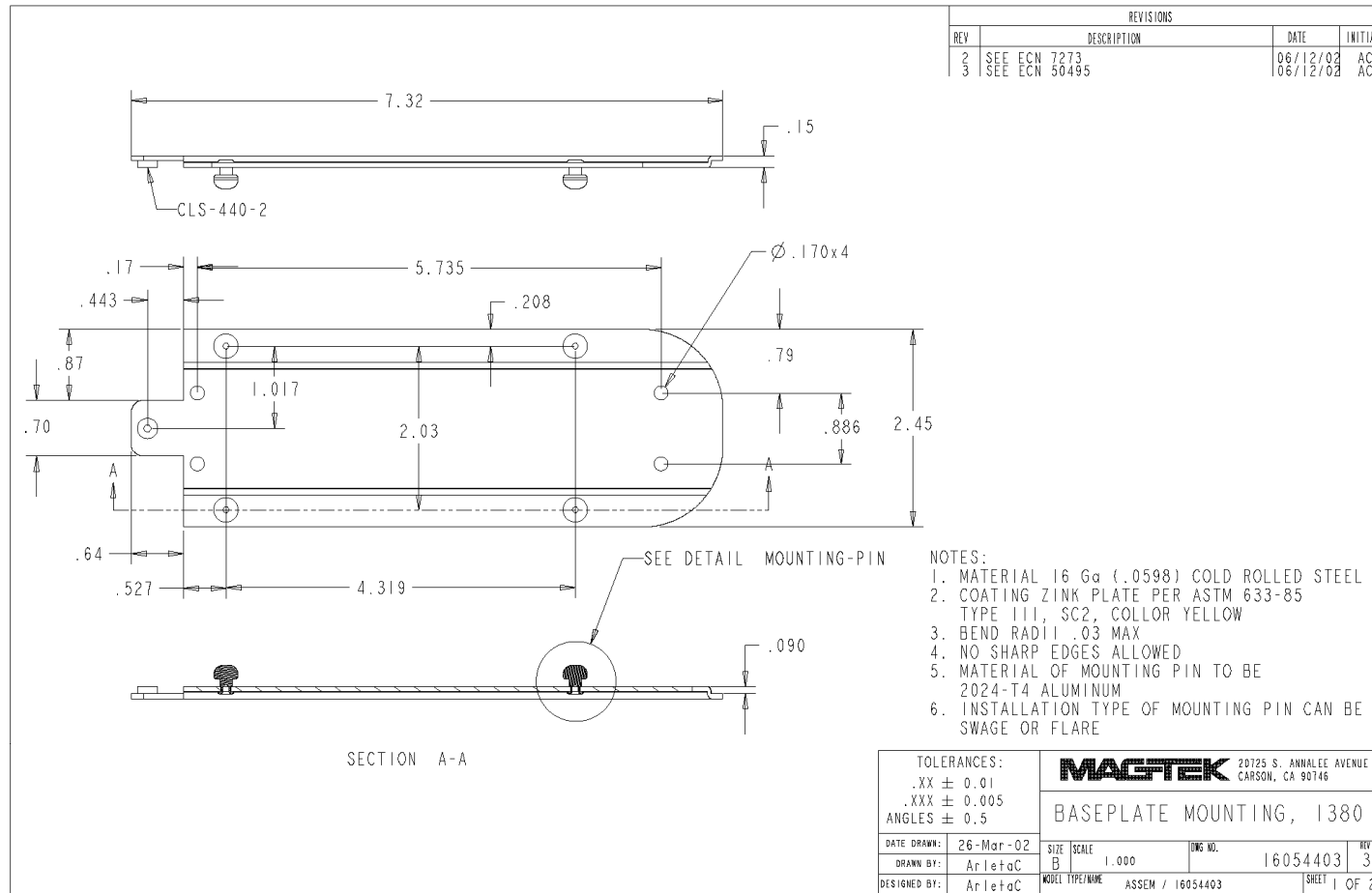

Figure A-3. MagTek Mounting Plate, 1

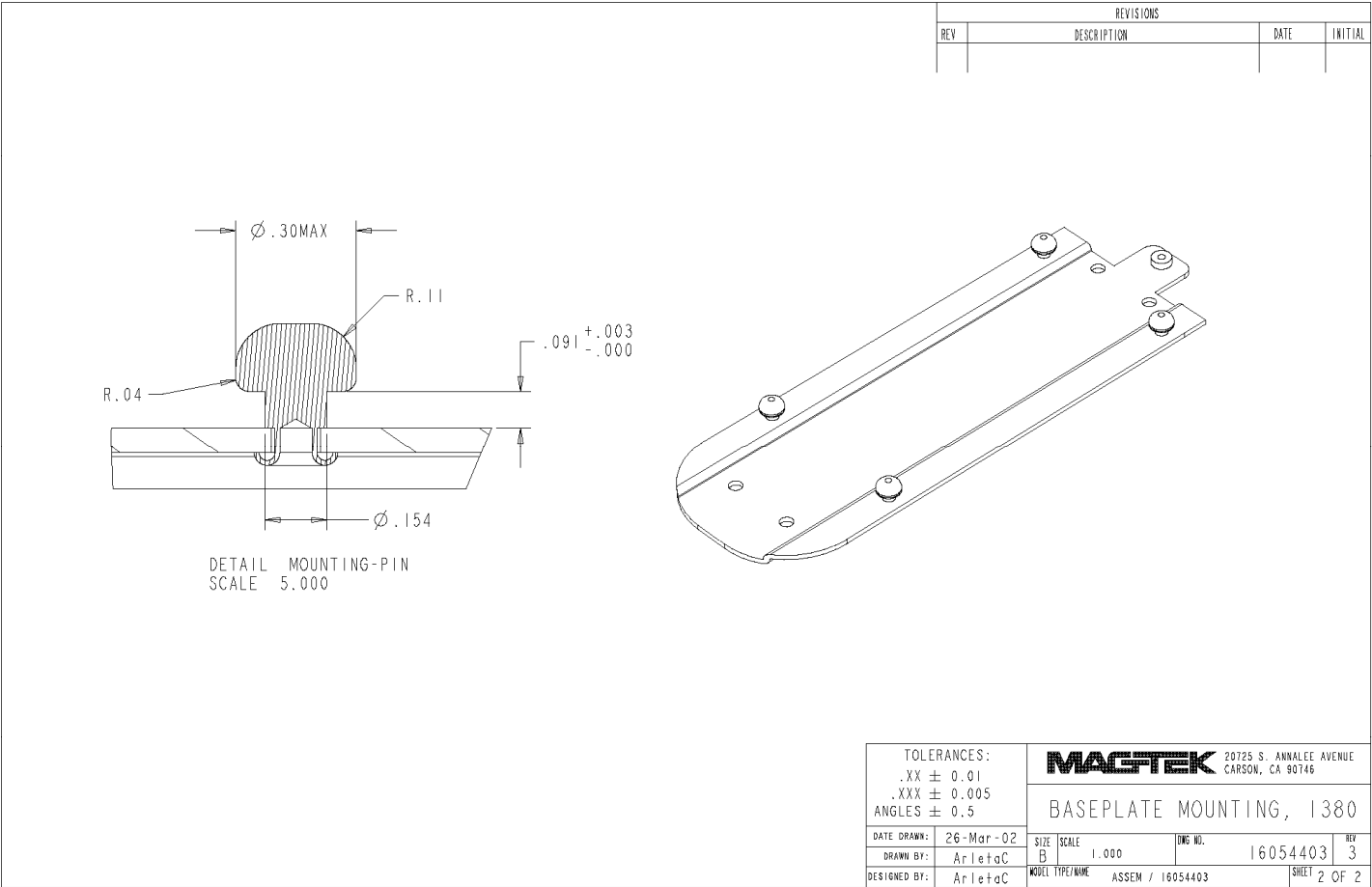

Figure A-4. MagTek Mounting Plate, 2

