

**MODEL MT-215232
RS-232 INSERTION READER
TECHNICAL REFERENCE MANUAL**

Manual Part Number 99821504 Rev 6

APRIL 2003

MAGTEK[®]

REGISTERED TO ISO 9001:2000

1710 Apollo Court

Seal Beach, CA 90740

Phone: (562) 546-6400

FAX: (562) 546-6301

Technical Support: (651) 415-6800

www.magtek.com

Information in this document is subject to change without notice. No part of this document may be reproduced or transmitted in any form or by any means, electronic or mechanical, for any purpose, without the express written permission of MagTek, Inc.

MagTek is a registered trademark of MagTek, Inc.

REVISIONS

Rev Number	Date	Notes
2	5/3/96	Previous versions not assigned Rev Numbers
3	4/28/98	Changed Warranty to 90 days. Added Tech Support Phone Number.
4	01/01/01	Added MagTek Web address. Changed copyright date. Changed Warranty to one year. Added Agency Approvals.
5	07/29/02	Sec 1: First paragraph, adds AAMVA and CDL reads Trk 2 only; Configurations, deletes all current P/Ns and adds 2 new P/Ns; Specs, replaces Sprague with TI; Changes output driver OFF value from 30 to 50 V, Changed weight from 6 to 5 oz, Table 1-2, editorial. Sec 2: Switch Setting SWA, Table 2-1, added 150 to Baud Rate. Sec 3: Table 3-3 broken into 2 tables for clarity, Clarified signals and power and connectors, Clarified LED connections and indicators, Clarified user drivers. Sec 4: removed.
6	08 Apr 03	Front Matter: added ISO line to logo, changed Tech Support phone number, changed to new warranty, changed warranty from 90 days to 1 year.

LIMITED WARRANTY

MagTek warrants that the products sold to Reseller pursuant to this Agreement will perform in accordance with MagTek's published specifications. This warranty shall be provided only for a period of one year from the date of the shipment of the product from MagTek (the "Warranty Period"). This warranty shall apply only to the original purchaser unless the buyer is authorized by MagTek to resell the products, in which event, this warranty shall apply only to the first repurchase.

During the Warranty Period, should this product fail to conform to MagTek's specifications, MagTek will, at its option, repair or replace this product at no additional charge except as set forth below. Repair parts and replacement products will be furnished on an exchange basis and will be either reconditioned or new. All replaced parts and products become the property of MagTek. This limited warranty does not include service to repair damage to the product resulting from accident, disaster, unreasonable use, misuse, abuse, customer's negligence, Reseller's negligence, or non-MagTek modification of the product. MagTek reserves the right to examine the alleged defective goods to determine whether the warranty is applicable.

Without limiting the generality of the foregoing, MagTek specifically disclaims any liability or warranty for goods resold in other than MagTek's original packages, and for goods modified, altered, or treated by customers.

Service may be obtained by delivering the product during the warranty period to MagTek (1710 Apollo Court, Seal Beach, CA 90740). If this product is delivered by mail or by an equivalent shipping carrier, the customer agrees to insure the product or assume the risk of loss or damage in transit, to prepay shipping charges to the warranty service location and to use the original shipping container or equivalent. MagTek will return the product, prepaid, via a three (3) day shipping service. A Return Material Authorization (RMA) number must accompany all returns.

MAGTEK MAKES NO OTHER WARRANTY, EXPRESS OR IMPLIED, AND MAGTEK DISCLAIMS ANY WARRANTY OF ANY OTHER KIND, INCLUDING ANY WARRANTY OF MERCHANTABILITY OR FITNESS FOR A PARTICULAR PURPOSE.

EACH PURCHASER UNDERSTANDS THAT THE MAGTEK PRODUCT IS OFFERED AS IS. IF THIS PRODUCT DOES NOT CONFORM TO MAGTEK'S SPECIFICATIONS, THE SOLE REMEDY SHALL BE REPAIR OR REPLACEMENT AS PROVIDED ABOVE. MAGTEK'S LIABILITY, IF ANY, TO RESELLER OR TO RESELLER'S CUSTOMERS, SHALL IN NO EVENT EXCEED THE TOTAL AMOUNT PAID TO MAGTEK BY RESELLER UNDER THIS AGREEMENT. IN NO EVENT WILL MAGTEK BE LIABLE TO THE RESELLER OR THE RESELLER'S CUSTOMER FOR ANY DAMAGES, INCLUDING ANY LOST PROFITS, LOST SAVINGS OR OTHER INCIDENTAL OR CONSEQUENTIAL DAMAGES ARISING OUT OF THE USE OF OR INABILITY TO USE SUCH PRODUCT, EVEN IF MAGTEK HAS BEEN ADVISED OF THE POSSIBILITY OF SUCH DAMAGES, OR FOR ANY CLAIM BY ANY OTHER PARTY.

LIMITATION ON LIABILITY

EXCEPT AS PROVIDED IN THE SECTIONS RELATING TO MAGTEK'S LIMITED WARRANTY, MAGTEK'S LIABILITY UNDER THIS AGREEMENT IS LIMITED TO THE CONTRACT PRICE OF THE PRODUCTS.

MAGTEK MAKES NO OTHER WARRANTIES WITH RESPECT TO THE PRODUCTS, EXPRESSED OR IMPLIED, EXCEPT AS MAY BE STATED IN THIS AGREEMENT, AND MAGTEK DISCLAIMS ANY IMPLIED WARRANTY, INCLUDING WITHOUT LIMITATION ANY IMPLIED WARRANTY OF MERCHANTABILITY OR FITNESS FOR A PARTICULAR PURPOSE.

MAGTEK SHALL NOT BE LIABLE FOR CONTINGENT, INCIDENTAL, OR CONSEQUENTIAL DAMAGES TO PERSONS OR PROPERTY. MAGTEK FURTHER LIMITS ITS LIABILITY OF ANY KIND WITH RESPECT TO THE PRODUCTS, INCLUDING ANY NEGLIGENCE ON ITS PART, TO THE CONTRACT PRICE FOR THE GOODS.

MAGTEK'S SOLE LIABILITY AND BUYER'S EXCLUSIVE REMEDIES ARE STATED IN THIS SECTION AND IN THE SECTION RELATING TO MAGTEK'S LIMITED WARRANTY.

FCC WARNING STATEMENT

This equipment has been tested and found to comply with the limits for a Class A digital device, pursuant to Part 15 of FCC Rules. These limits are designed to provide reasonable protection against harmful interference when the equipment is operated in a commercial environment. This equipment generates, uses, and can radiate radio frequency energy and, if not installed and used in accordance with the instruction manual, may cause harmful interference to radio communications. Operation of this equipment in a residential area is likely to cause harmful interference in which case the user will be required to correct the interference at his own expense.

FCC COMPLIANCE STATEMENT

This device complies with Part 15 Of The FCC Rules. Operation of this device is subject to the following two conditions: (1) This device may not cause harmful interference. And (2) This device must accept any interference received, including interference that may cause undesired operation.

CANADIAN DOC STATEMENT

This digital apparatus does not exceed the Class A limits for radio noise for digital apparatus set out in the Radio Interference Regulations of the Canadian Department of Communications.

Le présent appareil numérique n'émet pas de bruits radioélectriques dépassant les limites applicables aux appareils numériques de la classe A prescrites dans le Règlement sur le brouillage radioélectrique édicté par le ministère des Communications du Canada.

CE STANDARDS

Testing for compliance to CE requirements was performed by an independent laboratory. The unit under test was found compliant to Class A.

UL/CSA

This product is recognized per Underwriter Laboratories and Canadian Underwriter Laboratories 1950.

TABLE OF CONTENTS

SECTION 1. FEATURES AND SPECIFICATIONS	1
FEATURES	1
MODES OF OPERATION	2
Unbuffered Mode	2
Buffered Mode	2
CONFIGURATIONS	3
SPECIFICATIONS	4
PIN LIST AND I/O SIGNALS	6
SECTION 2. INSTALLATION	7
MOUNTING	7
SWITCH SETTINGS	9
Switch SWA	9
Switch SWB	10
SECTION 3. COMMANDS, FORMATS, TIMING	13
HOST TO READER COMMANDS	13
READER TO HOST FORMATS	13
Successful Card Read	14
Unsuccessful Card Read	15
No Card Read	16
INTERFACE WIRE LIST FOR MT-215232	17
Control Signals	17
Power and Connector Mating	17
LED Connections	19
TIMING	20
INDICATORS	20
USER DRIVERS	21

ILLUSTRATIONS

Figure 1-1. RS-232 Insertion Reader	vi
Figure 1-2. Dimensions	5
Figure 2-1. Switches and Connector	7
Figure 2-2. Mounting Dimensions	8
Figure 3-1. Successful Card Read	14
Figure 3-2. Unsuccessful Card Read	15
Figure 3-3. No Card Read	16
Figure 3-4. Transmission Timing	20

TABLES

Table 1-1. Specifications	4
Table 1-2. J2 Connector Signals	6
Table 2-1. Baud Rate Setting	9
Table 2-2. Parity Setting	9
Table 3-1. Commands and Responses - I and R Commands	13
Table 3-2. Commands and Responses – Auxiliary Driver Commands	13
Table 3-3. D9 Without Control Signals	18
Table 3-4. D25 Without Control Signals	18
Table 3-5. D9 With Control Signals	19
Table 3-6. D25 With Control Signals	19

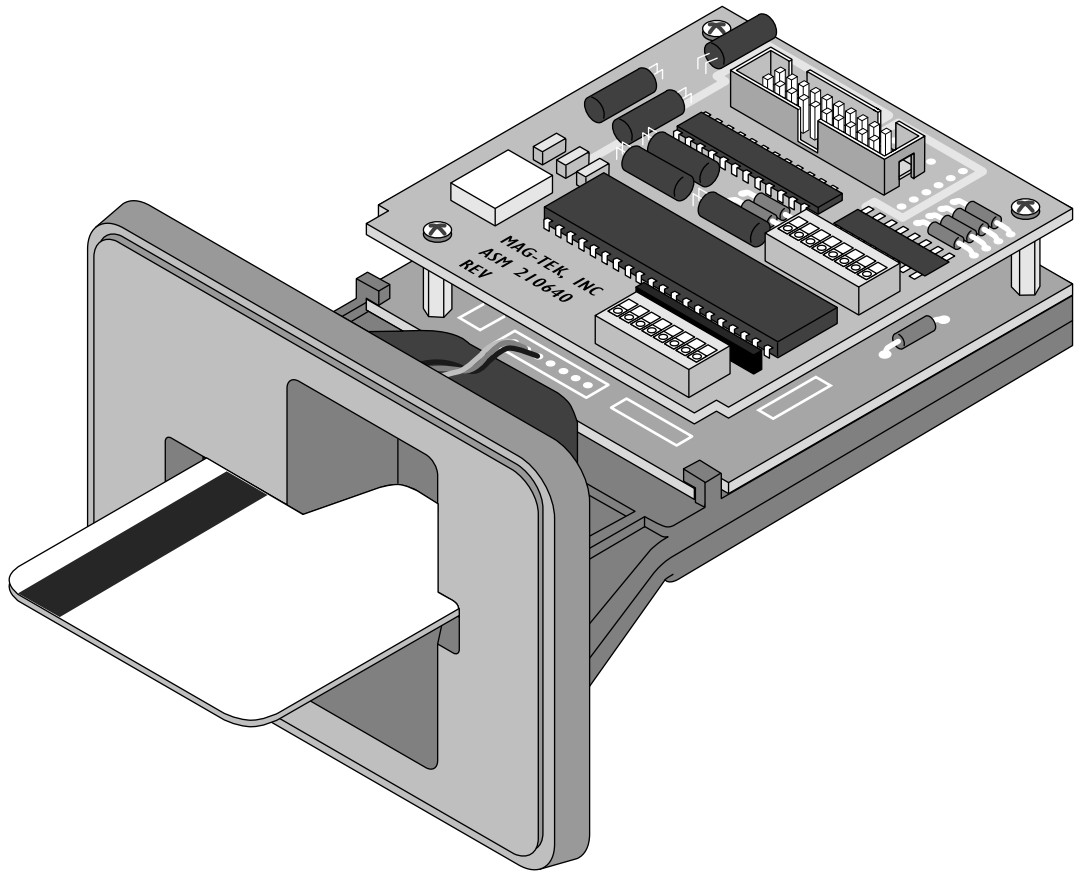

Figure 1-1. RS-232 Insertion Reader

SECTION 1. FEATURES AND SPECIFICATIONS

The Model MT-215232 Insertion Reader is a magnetic stripe card reader, which reads single or dual tracks of alphanumeric or numeric data in formats established by the credit card industry. For AAMVA and CDL, the Reader reads track 2 only.

The Reader is compatible with the PC AT/PS2 series of personal computers or any computer with an RS-232 interface. The MT-215 will read cards that meet the standards defined by ISO 7810, 7811-1, 7811-2, 7811-3, 7811-4, 7811-5, and 7811-6.

A card is inserted all the way into the reader and withdrawn with a steady motion. A read attempt is made during insertion and removal of the card.

Two blocks of eight switches each select the RS-232 protocol including baud rate, parity, and framing characters. The switches also select buffered and unbuffered modes of operation and enable command selection from the Host to the Reader.

FEATURES

Major features of the Insertion Reader are as follows:

- Hardware compatible with PC or any computer with an RS-232 interface.
- Switch selectable buffered or unbuffered modes of operation
- Switch selectable baud rate
- Switch selectable parity
- On/off switches for STX (Start of Text), ETX (End of Text), and ESC (ESCAPE) framing characters.
- On/off switch for CR (Carriage Return)
- Magnetic stripe read during insertion and removal of card
- ASCII message format
- Two auxiliary drivers for Reader status, or to actuate devices such as solenoids, or relays

MODES OF OPERATION

The Reader can operate in either unbuffered or buffered mode. The descriptions are as follows:

Unbuffered Mode

When a card is inserted and removed, a read attempt is made during both insertion and removal. Upon removal of the card if the read is successful, data (including the two sentinel characters) is sent to the Host. The data is transmitted immediately and not retained in the Reader.

When operating in the unbuffered mode, the Reader does not need to received commands from the Host in order to transmit data or status characters; however, the Reader does respond to an “Inquiry Command” by sending status characters. The inquiry command that requests the transmission of status characters is the ESCAPE (ESC) character followed by the ASCII character “I”.

The Reader must be turned off before selecting the operating mode. Refer to Section 2 for switch settings.

Note

The insertion and removal of the card must be done in a continuous motion. If not, the Reader may not read the encoded data properly. In that case, the Reader responds by either transmitting the ASCII character “E” representing an error, or by not transmitting any character, which indicates that the Reader has not detected data and the card was not completely inserted.

Buffered Mode

When a card is inserted and removed, a read attempt is made during both insertion and removal. Upon removal of the card if the read is successful, data (including the two sentinel characters) is stored in a memory buffer on the Reader and is not transmitted until the Reader receives an “Inquiry Command” from the Host. This command is the ESCAPE character followed by the ASCII “I”. The Reader cannot read another card until the buffer is cleared. To clear the buffer, the Host must transmit the ESCAPE character followed by The ASCII “R”.

The Reader must be turned off before selecting the operating mode. Refer to Section 2 for switch settings

Note

The insertion and removal of the card must be done in a continuous motion. If not, the Reader may not read the encoded data properly. In that case, the Reader responds to an inquiry command by either transmitting the ASCII character “E” representing an error, or by just transmitting status characters, which indicates that the Reader has not detected any data and the card was not completely inserted.

CONFIGURATIONS

The following list includes part numbers and available track configurations:

	Part Number	Read	Bezel
Multiple Tracks	21065127	Tracks 1, 2	No Bezel
	21065132	Tracks 1, 2	Flat Face Bezel

SPECIFICATIONS

Table 1-1 lists the specifications for the RS-232 Insertion Reader.

Table 1-1. Specifications

OPERATING

Reference Standards	ANSI/ISO
Power Input	+5V DC - Requires +4.75 V DC to +5.25 V DC @ 0.045 A
Power Consumption	0.225 WATTS
Auxiliary Drivers 1 and 2	Open Collector outputs, capable of driving visual indicators, solenoids, relays, etc. Outputs driven by Texas Instruments ULN 2003AN. Any use of these drivers must meet the following: ON = 0.8V @ 0.2 amps max. OFF = 50.0V max. (See Texas Instruments Data Sheet for parameters.)
Interface Signal	RS-232E
Message Format	ASCII (7 Data Bits + Parity Bit)
Track Card Speed	TRK 1 or 3: 3 to 50 IPS (127 cm) at 210 BPI. TRK 2: 3 to 50 IPS (127 cm) at 75 BPI
MTBF	Electronics: 120,000 hours Head: 1,000,000 passes (500,000 insertion cycles)

MECHANICAL

Dimensions (with Bezel)	
Length	4.58 " (11.63cm)
Width	4" (10.16 cm)
Height	3" (7.62 cm)
Bezel Thickness	0.31" (0.79 cm)
Weight	5.42 oz. (154 g.)

ENVIRONMENTAL

Temperature	
Operating	0°C to 70°C (32°F to 158°F)
Storage	-40°C to 80°C (-40°F to 176°F)
Humidity	
Operating	10% to 90% noncondensing
Storage	0% to 100% noncondensing
Altitude	
Operating	0-10,000 ft. (0-3,048 m.)
Storage	0-50,000 ft. (0-15,240 m.)

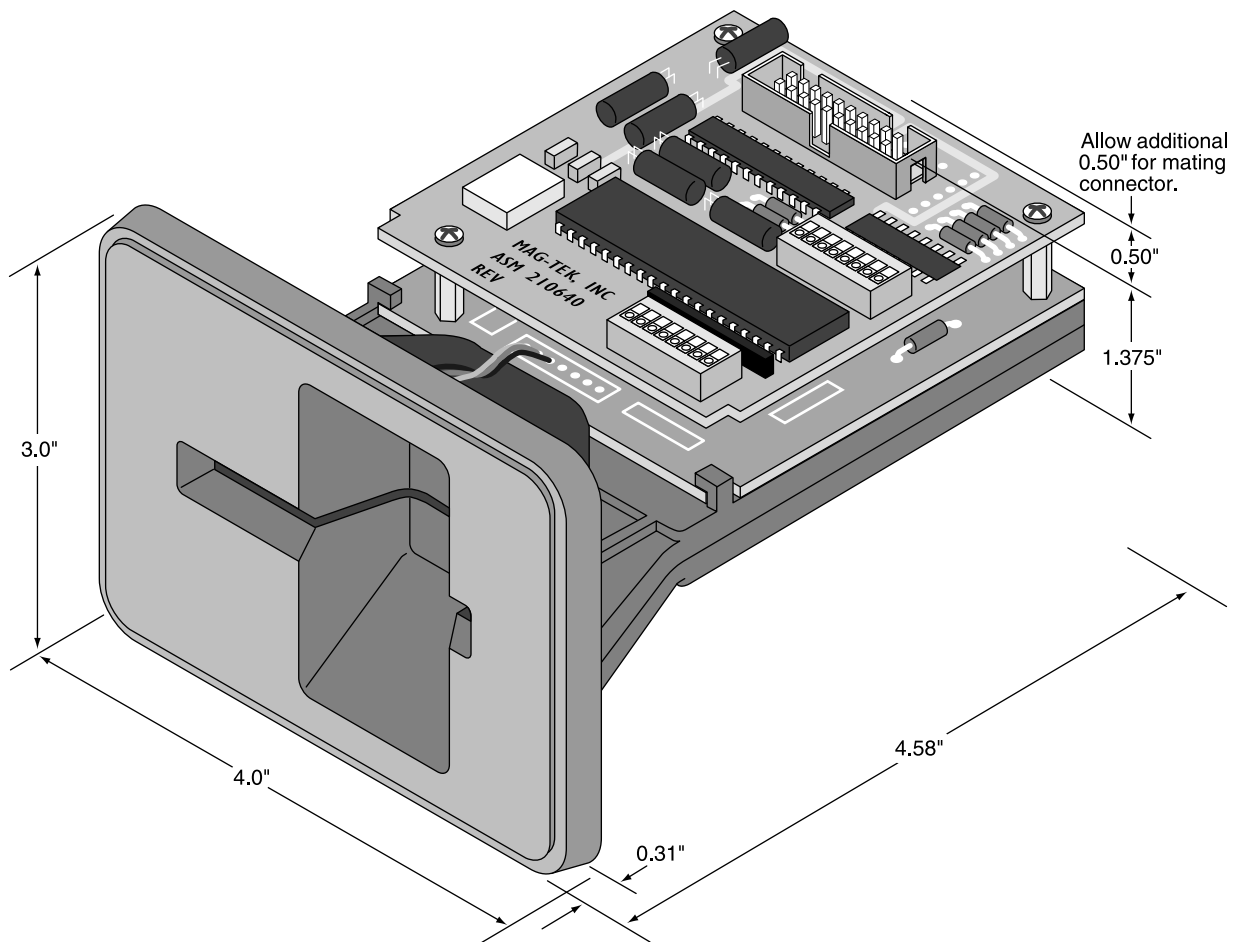

Figure 1-2. Dimensions

PIN LIST AND I/O SIGNALS

Table 1-2 lists the pin numbers, signals, and descriptions for connector J2 on the Reader. See Section 3 for the Interface Wire List for the MT215232.

Table 1-2. J2 Connector Signals

Pin Number	Signal	Description
1,2	+5v	Either one or both pins can be connected to a +5V power supply. See Specifications, Section 1 for ratings.
3,4	GND	Either one or both pins can be used as circuit ground.
5	DSR	Data Set Ready, RS-232E signal. Indicates to the Reader that the Host is active.
6		Used for factory testing only.
7	DTR	Data Terminal Ready, RS-232 signal. Indicates to the Host that the Reader is active.
8*	AUX 1	Auxiliary driver 1. Operated by commands from the Host.
9	CTS	Clear to sent, RS-232C signal. Signal from the Host to the Reader allowing data to be transmitted.
10*	AUX 2	Auxiliary driver 2. Operated by commands from the Host.
11	RTS	Request to send, RS-232E signal. The Reader transmits the signal to the Host indicating the Reader is ready to transmit data.
12	CARD PRESENT	Used for factory testing only.
13	RD	Received data, RS-232E signal. Reader receives data sent from the Host.
14***	REAR SENSOR BLOCKED	Indicates the presence of a card when it is fully inserted in the reader.
15	TD	Transmitted data, RS-232E signal. Transmits data from the Reader to the Host.
16***	BUSY	Used for factory testing only.
17**	N/C	In previous versions of the Reader this pin was used for -12V.
18***	READY	Indicates the unit is ready to accept a card.
19**	N/C	In previous versions of the Reader this pin was used for +12V.
20***	ERROR	Indicates an unsuccessful read attempt. This signal remains active for 2.0 seconds.

*These signals are open collector outputs, capable of driving visual indicators, solenoids, relays, etc. The outputs are driven by a Texas Instruments ULN 2003AN. Any use of these drivers must meet the following specifications: ON = 0.8V @0.2 amps max. OFF = 50.0V max.

**The 5V to +12V/-12V conversion is now being done on the processor board. Pins 17 and 19 (which formerly transmitted the +12V/-12V) now have no connection so that the new version of the Reader can be used interchangeably with the old version of the Reader.

***See Section 3 for details and mating connectors.

SECTION 2. INSTALLATION

The installation consists of mounting the Reader, connecting the cable, and settings the switches. Other considerations such as commands, responses, formats and timing are given in Section 3.

The switches and the connector are shown in Figure 2-1. The pin list for the connector is presented in Section 1 under Specifications. The illustration in Section 1 also shows clearance dimensions of the Reader.

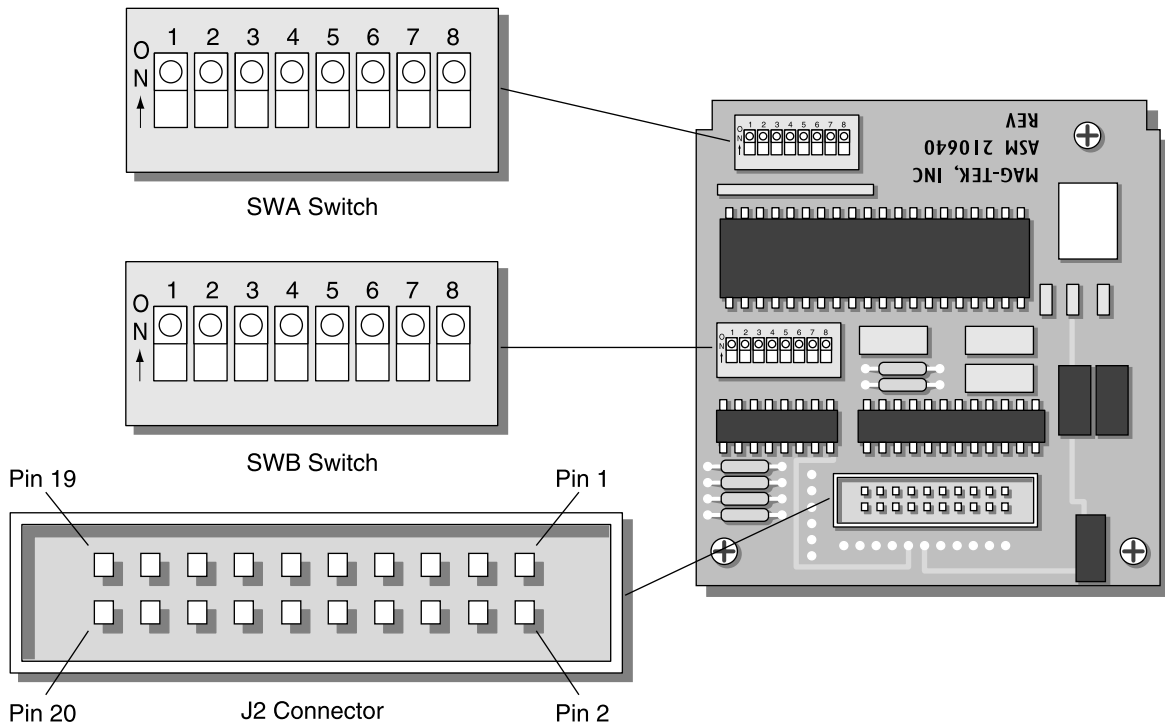

Figure 2-1. Switches and Connector

MOUNTING

Figure 2-2 shows dimensions for mounting considerations.

MT-215232 Insertion Reader

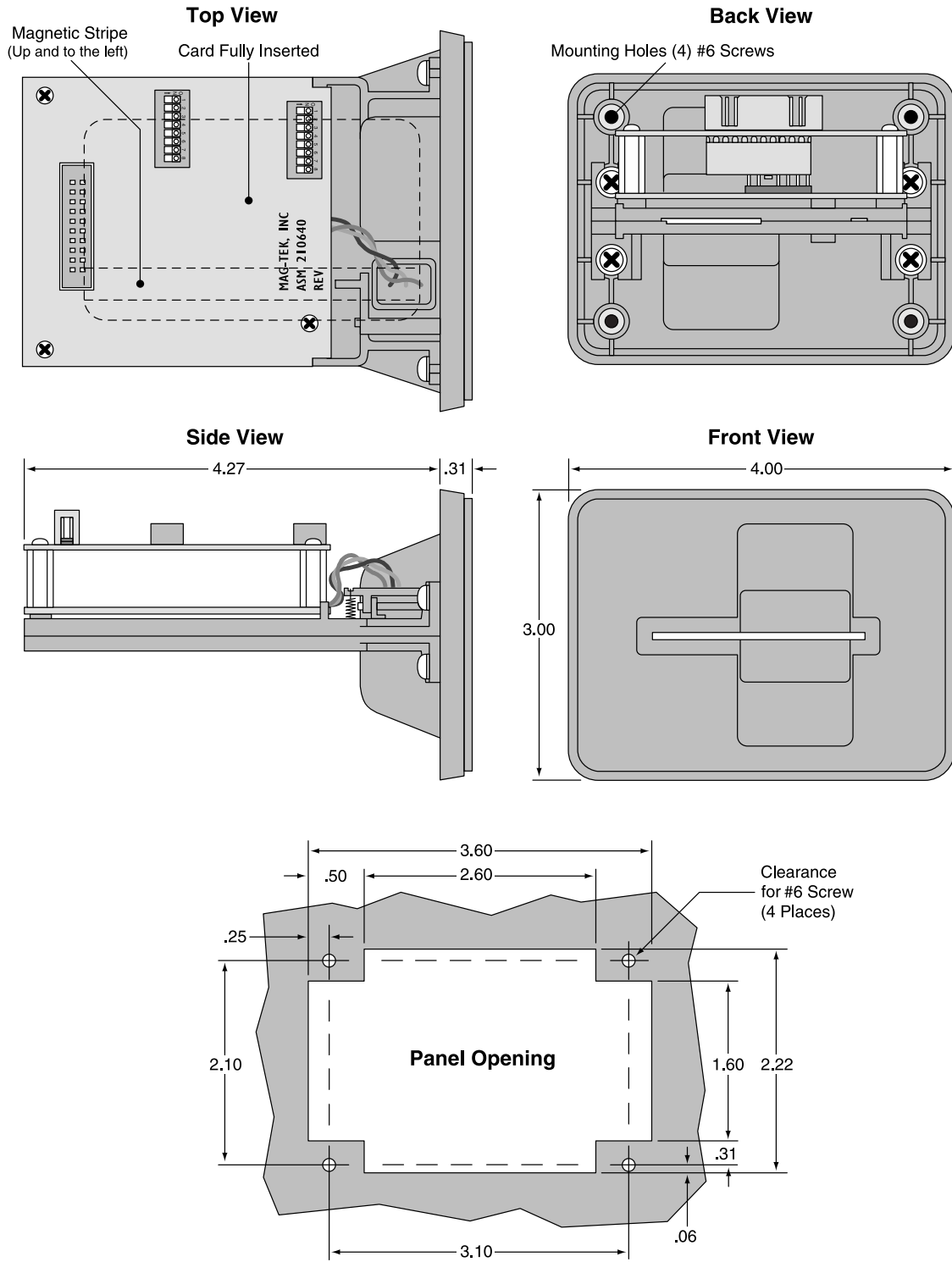

Figure 2-2. Mounting Dimensions

SWITCH SETTINGS

The switch positions and orientations are shown in Figure 2-1. The switches must be set while power is off to ensure that the switch settings are properly loaded. As shown in the illustration and designated on the printed circuit board, the switches are SWA and SWB. Set the switches as described below.

Switch SWA

On SWA switches 1, 2 and 3 set the baud rate. This is the rate at which data is transmitted and received between the Reader and the Host. The switch settings are shown in Table 2-1.

Table 2-1. Baud Rate Setting

BAUD RATE	SWA1	SWA2	SWA3
150	ON	ON	ON
300	OFF	ON	ON
600	ON	OFF	ON
1200	OFF	OFF	ON
2400	ON	ON	OFF
4800	OFF	ON	OFF
9600	ON	OFF	OFF
19200	OFF	OFF	OFF

On SWA switches 4 and 5 set the parity as shown in Table 2-2.

Table 2-2. Parity Setting

PARITY SENT	SWA4	SWA5	RECEIVED PARITY CHECK
ODD	ON	ON	ODD
EVEN	OFF	ON	EVEN
ONE (MARK)	ON	OFF	IGNORED
ZERO (SPACE)	OFF	OFF	IGNORED

SWA6:

Sets the Start of Text (STX) framing character. This character is optional. Set SW6 to ON if STX is required and to OFF if it is not.

SWA7:

Sets the ESCAPE character. This character is optional. Set SW7 to ON if ESCAPE is implemented and OFF if it is not.

SWA8:

Sets the End of Text (ETX) framing character. This character is optional. Set SW8 to ON if ETX is implemented and OFF if it is not.

Switch SWB

SWB1:

Sets the Carriage Return (CR). This character is optional. Set SWB1 to ON if CR is to be implemented and OFF if it is not.

SWB2:

Sets the operating mode of Buffered or Unbuffered. Set SWB2 to ON for Buffered or OFF for Unbuffered.

SWB3:

Two open collector auxiliary drivers are available to the user. The status of these drivers is reported by the bytes of information following the transmitted card data. If the drivers are not used, these status bytes may be suppressed by setting the switch to OFF. The status bytes are transmitted if the switch is set to ON.

SWB4:

Factory set to ON for “I” and “R”, OFF for “+” and “-” See Section 3, Operation, under Host to Reader Commands.

SWB5:

Factory set to OFF (must not be changed).

SWB6:

Factory set to OFF (for the most reliable operation should not be changed). Reader will read upon insertion and withdrawal. If set to the ON position, the Reader will read on Insert only. Data is transmitted upon contact of the rear sensor.

SWB7:

Set to the ON position to jumper the control signals RTS-CTS. Set to OFF is these signals are implemented by the Host.

SWB8:

Set to the ON position to jumper the control signals DSR-DTR. Set to OFF is these signals are implemented by the Host.

Notes:

1. In previous versions of the Reader, a switch was used to enable reading either a 5-bit data format or a 7-bit data format. In this version the function of reading a 7- or 5-bit format is performed automatically by the firmware.
2. Switches that are factory set must be set in the position indicated when used by the customer. The Reader is one of a series of products using the same microcontroller. The factory set switches make the microcontroller function properly in the Reader.

SECTION 3. COMMANDS, FORMATS, TIMING

This section includes commands from the Host to the Reader, Reader to Host message formats, transmission timing, and possible uses of drivers.

HOST TO READER COMMANDS

All commands transmitted from the Host to the Reader must be preceded by the ASCII “ESCAPE” character. These command messages may contain other framing characters, which are ignored by the Reader. Table 3-1 describes I and R commands, a switch selectable option for the ASCII command character and the Reader response to the Host. Table 3-2 describes the second character commands

Table 3-1. Commands and Responses - I and R Commands

HOST COMMANDS		READER RESPONSES
ASCII “ESCAPE” CHARACTER (1B hex)	SWITCH SELECTABLE ASCII CHARACTER - SWB4	
	ON	OFF
<ESC>	I	+
<ESC>	R	-

Table 3-2. Commands and Responses – Auxiliary Driver Commands

ASCII “ESCAPE” CHARACTER (1B hex)	ASCII SECOND CHARACTER	READER RESPONSES
<ESC>	0	Deactivates both user drivers 1 and 2.
<ESC>	1	Activates user driver 1.
<ESC>	2	Activates user driver 2.
<ESC>	3	Deactivates user driver 1.
<ESC>	4	Deactivates user driver 2

READER TO HOST FORMATS

The following diagrams represent the formats of the data transmitted after a successful card read, an unsuccessful card read, and no card read which is the response if the Host inquires and the buffer is empty.

Successful Card Read

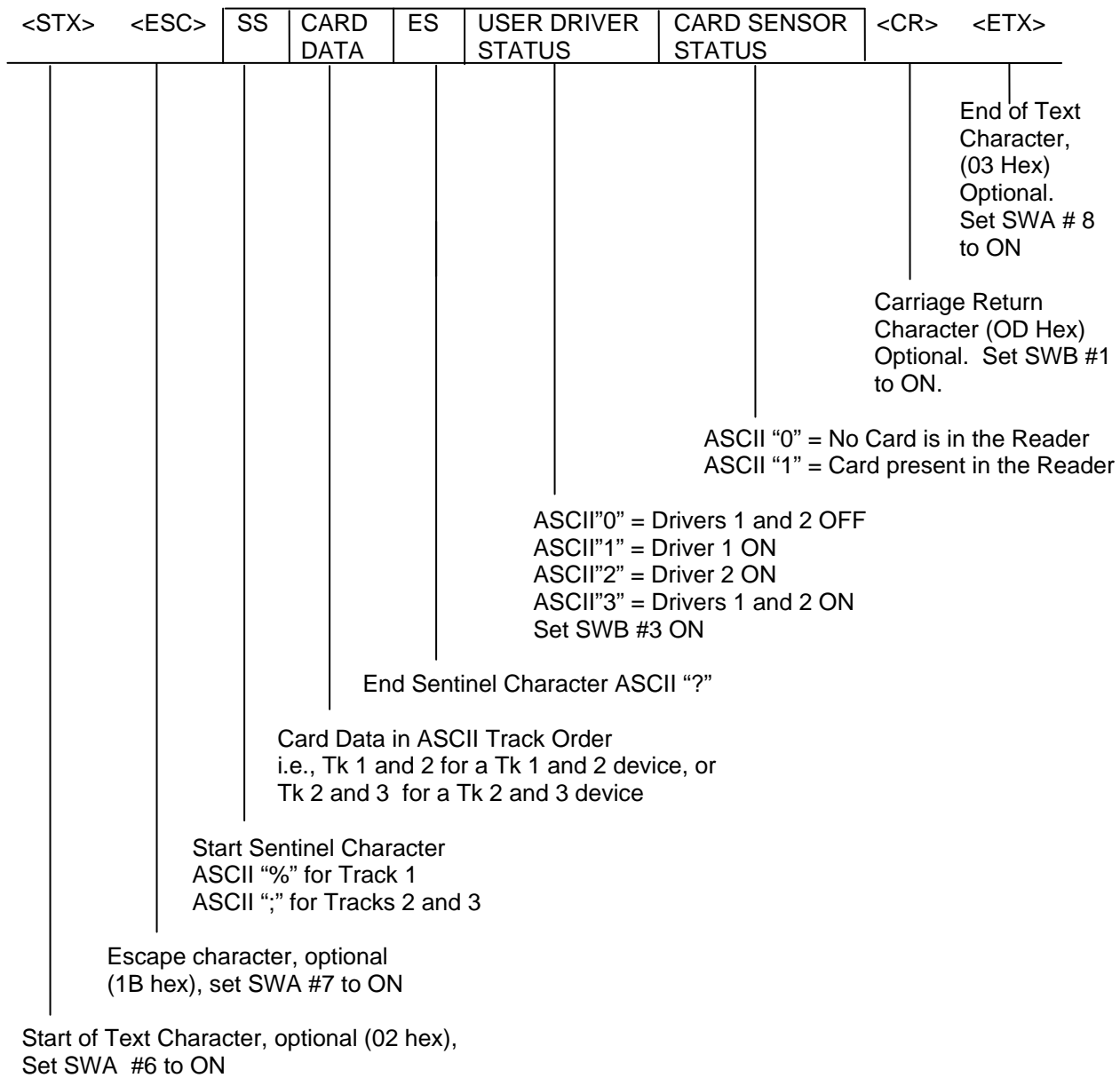

- Notes:**
1. Optional characters are used to frame the data.
 2. The LRC character is not transmitted.
 3. The optional Hex characters are shown with the parity bit as zero ("0").

Figure 3-1. Successful Card Read

Unsuccessful Card Read

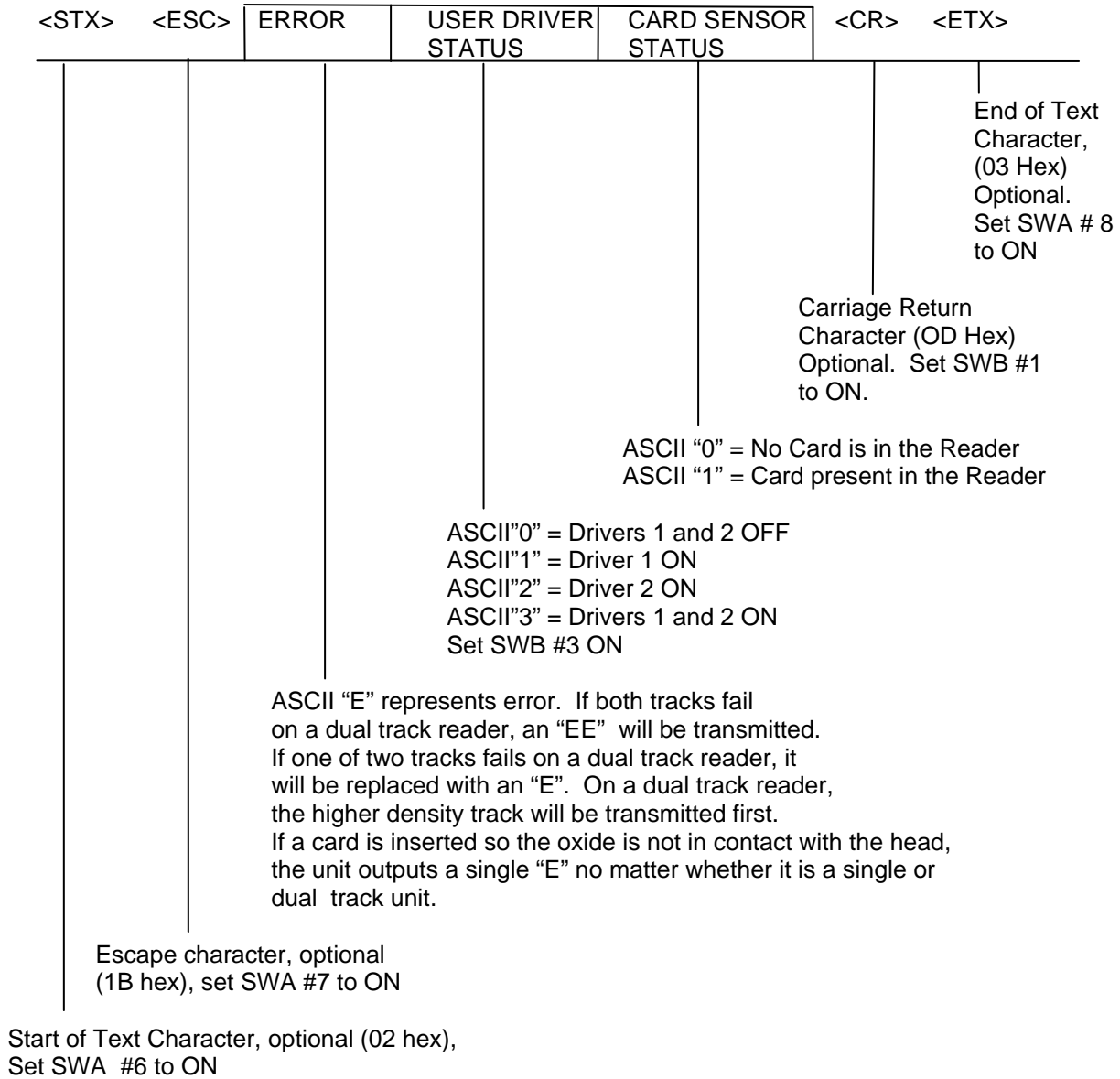

- Notes:**
1. Optional characters are used to frame the data.
 2. The optional Hex characters are shown with the parity bit as zero ("0").

Figure 3-2. Unsuccessful Card Read

No Card Read

The No Card Read is the response if the Host inquires (Esc I) and the buffer is empty.

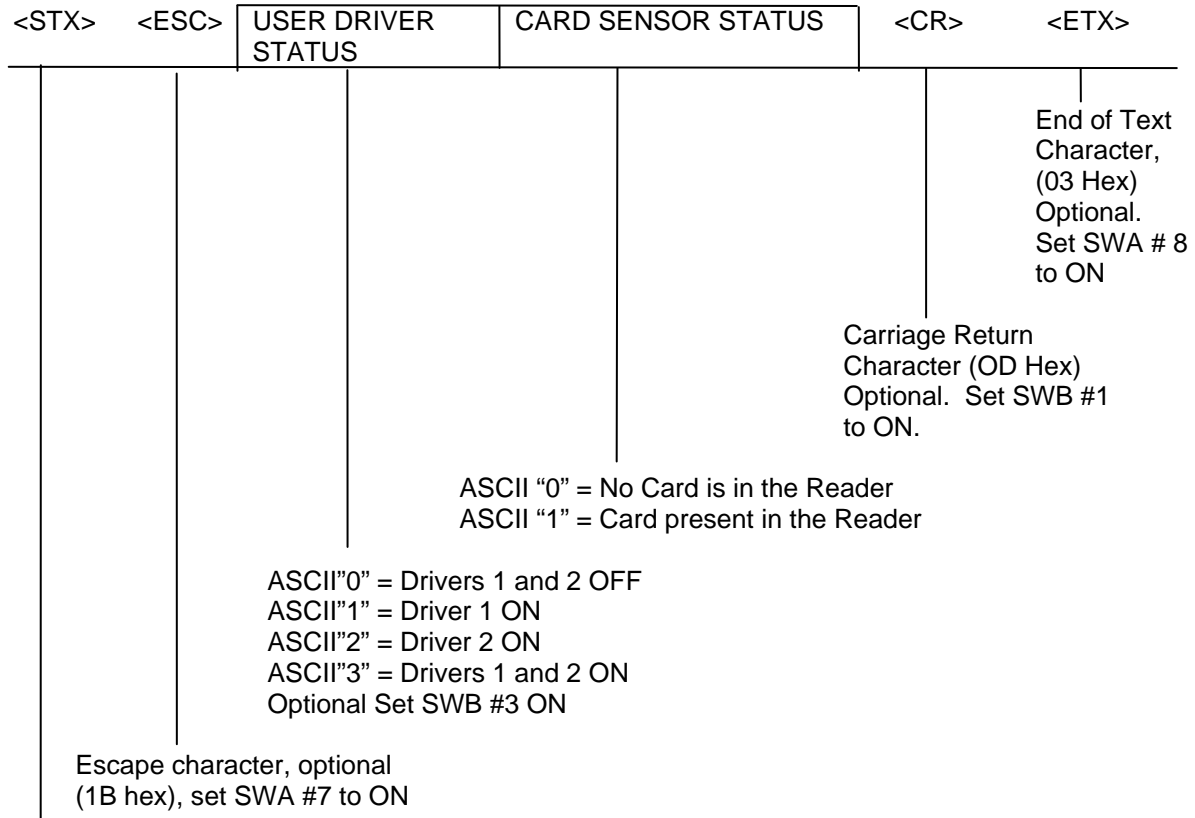

Start of Text Character, optional (02 hex), Set SWA #6 to ON

- Notes:**
1. Optional characters are used to frame the data.
 2. The optional Hex characters are shown with the parity bit as zero ("0").

Figure 3-3. No Card Read

INTERFACE WIRE LIST FOR MT-215232

The interface wire list describes the unit with and without control signals in the buffered and unbuffered modes, D9 and D25 connectors, and LED connections.

Control Signals

The control signals are defined as: DSR, pin 5; DTR, pin 7; CTS, pin 9; RTS, pin 11.

Without control signals in the unbuffered mode, the card reader will transmit the data immediately upon removal of the card.

Without control signals in the buffered mode, the card reader will transmit the data upon removal of the card and immediately after the Host has polled the card reader.

With control signals connected in the unbuffered mode, the unit will signal the Host (RTS goes positive) when it has a message and wait for the Host to signal that it is ready to accept the data. The Host raises CTS to a positive level to receive the data, and RTS will return to negative after data has been transmitted.

With control signals connected in the buffered mode, after the card is removed and polled by the Host, and the Host signals that it is ready to accept data, the data will be transmitted.

Note

Normally this last configuration is not used if the Host has full command of the control signals

Power and Connector Mating

The +5 VDC \pm 5% at 0.045 Amps power can be obtained from an external power supply or from the Host (not available on the "D" COM port connector).

The reader mates to a 20 pin connector (P2), and the Host has a "D type" connector (P3) which is normally designated as Com 1 or Com 2.

Part numbers for the 3M interface: Connector 3421-6000; Flat gray cable 3365-20; or Flat multi-color cable: 3302-20.

Tables 3-2 through 3-5 describe the correct wiring schemes for 25- and 9-pin "D" connectors with and without control signals.

Table 3-3 is used when the Host has a 9-pin “D” connector without control signals.

Note

Switches SWB7 and SWB8 must be ON for this configuration.

Table 3-3. D9 Without Control Signals

READER	HOST
P2-1 TO	+5 VDC POWER
P2-3 TO	POWER SUPPLY GROUND (RETURN)
P2-4 TO	P3-5
P2-13 TO	P3-3
P2-15 TO	P3-2
	P3-7 TO P3-8
	P3-1 TO P3-4 TO P3-6

Table 3-4 is used when the Host has a 25-pin “D” connector without control signals.

Note

Switches SWB7 and SWB8 must be ON for this configuration.

Table 3-4. D25 Without Control Signals

READER	HOST
P2-1 TO	+5 VDC POWER
P2-3 TO	POWER SUPPLY GROUND (RETURN)
P2-4 TO	P3-7
P2-13 TO	P3-2
P2-15 TO	P3-3
	P3-4 TO P3-5
	P3-6 TO P3-8 TO P3-20

Table 3-5 is used when the Host has a 9-pin “D” connector with control signals.

Note

Switches SWB7 and SWB8 must be OFF for this configuration.

Table 3-5. D9 With Control Signals

READER	CONNECT TO HOST
P2-1 TO	+5 VDC POWER
P2-3 TO	POWER SUPPLY GROUND (RETURN)
P2-4 TO	P3-5
P2-5 TO P2-9 TO	P3-4
P2-7 TO	P3-6 TO P3-8
P2-11 TO	P3-1
P2-13 TO	P3-3
P2-15 TO	P3-2

Table 3-6 is used when the Host has a 25-pin “D” connector with control signals.

Table 3-6. D25 With Control Signals

Note

Switches SWB7 and SWB8 must be OFF for this configuration.

READER	CONNECT TO HOST
P2-1 TO	+5 VDC POWER
P2-3 TO	POWER SUPPLY GROUND (RETURN)
P2-4 TO	P3-7
P2-5 TO P2-9 TO	P3-20
P2-7 TO	P3-6 TO P3-5
P2-11 TO	P3-8
P2-13 TO	P3-2
P2-15 TO	P3-3

LED Connections

It may be desirable to have a visual indication of the reader's status at the reader.

By adding two to three LED's (Light Emitting Diodes) to any of the above cables, this can be accomplished. Connect the anode of all LED's to +5 VDC.

MT-215232 Insertion Reader

Connect the cathode of a green LED to pin P2-18. This LED will illuminate when the card reader is READY to accept a card.

Connect the cathode of a red LED to pin P2-20. This LED will illuminate when the card reader has detected an ERROR. It will glow for 2 seconds after the card has been withdrawn if there was an error in reading any track.

The BUSY indicator is not very useful since it is on only when the ready LED is out. To use this LED, connect a yellow LED's cathode to P2-16.

Normally the anode is the longer lead on an LED to be connected to +5 VDC. The circuit has a built-in 220 ohm resistor to limit LED current on pins J2-14, J2-16, and J2-18.

TIMING

The Reader is capable of bidirectional communication with the Host. Transmission timing is shown in Figure 3-4. Each ASCII character is transmitted with 1 start bit, 7 data bits, 1 parity bit, and 1 stop bit. Logic levels conform to standard RS-232 levels; logic levels are “true” or “1” if the level is low (-9 VDC (quiescent state)) and “false” or “0” if the level is high (+9 VDC).

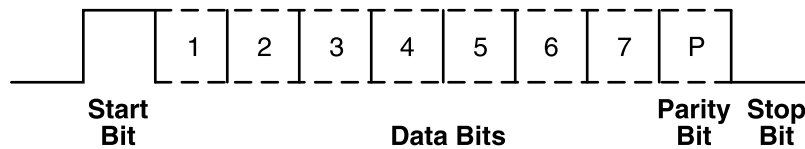

Figure 3-4. Transmission Timing

INDICATORS

There are three drivers in the Reader that may function as status indicators. They are:

REAR SENSOR (Pin J2-14): Indicates the presence of a card when it is fully inserted in the Reader.

ERROR (Pin J2-20): Indicates an unsuccessful read attempt. This indicator remains active for 2.0 seconds.

READY (Pin J2-18): Indicates that the unit is ready to accept a card.

See LED connections above.

USER DRIVERS

There are two user drivers activated or deactivated by commands from the Host, which can be defined in the Host system as indicators to prompt the operator. For Example, if the Reader sent a message to the Host indicating that it was not ready to read a card, the Host can turn one driver off. When the Host has completed a card read process, the driver would be turned back on, and a new transition could occur. Further applications of the two drivers include such functions as operating solenoids or relays. Ratings for the two drivers are listed in Section 1 under Specifications. For complete specifications, visit www.ti.com. Search ULN2003AN. Commands to activate or deactivate these drivers are shown in Table 3-2.

