

**MAXI MICR RS232
WITH OPTIONAL 2-TRACK MSR
TECHNICAL REFERENCE MANUAL**

Manual Part Number: 99875073 Rev 3

APRIL 2003

MAGTEK[®]

REGISTERED TO ISO 9001:2000

1710 Apollo Court

Seal Beach, CA 90740

Phone: (562) 546-6400

FAX: (562) 546-6301

Technical Support: (651) 415-6800

www.magtek.com

Information in this document is subject to change without notice. No part of this document may be reproduced or transmitted in any form or by any means, electronic or mechanical, for any purpose, without the express written permission of MagTek, Inc.

MagTek is a registered trademark of MagTek, Inc.

REVISIONS

Rev Number	Date	Notes
1	23 May 97	Initial Release
2	2 Aug 01	Front Matter, Agency page: Changed FCC to Class B, added UL/CUL.. Removed obsolete safety statement.
3	18 Apr 03	Front Matter: added ISO line to logo, changed Tech Support phone number, added new warranty statement.

LIMITED WARRANTY

MagTek warrants that the products sold to Reseller pursuant to this Agreement will perform in accordance with MagTek's published specifications. This warranty shall be provided only for a period of one year from the date of the shipment of the product from MagTek (the "Warranty Period"). This warranty shall apply only to the original purchaser unless the buyer is authorized by MagTek to resell the products, in which event, this warranty shall apply only to the first repurchase.

During the Warranty Period, should this product fail to conform to MagTek's specifications, MagTek will, at its option, repair or replace this product at no additional charge except as set forth below. Repair parts and replacement products will be furnished on an exchange basis and will be either reconditioned or new. All replaced parts and products become the property of MagTek. This limited warranty does not include service to repair damage to the product resulting from accident, disaster, unreasonable use, misuse, abuse, customer's negligence, Reseller's negligence, or non-MagTek modification of the product. MagTek reserves the right to examine the alleged defective goods to determine whether the warranty is applicable.

Without limiting the generality of the foregoing, MagTek specifically disclaims any liability or warranty for goods resold in other than MagTek's original packages, and for goods modified, altered, or treated by customers.

Service may be obtained by delivering the product during the warranty period to MagTek (1710 Apollo Court, Seal Beach, CA 90740). If this product is delivered by mail or by an equivalent shipping carrier, the customer agrees to insure the product or assume the risk of loss or damage in transit, to prepay shipping charges to the warranty service location and to use the original shipping container or equivalent. MagTek will return the product, prepaid, via a three (3) day shipping service. A Return Material Authorization (RMA) number must accompany all returns.

MAGTEK MAKES NO OTHER WARRANTY, EXPRESS OR IMPLIED, AND MAGTEK DISCLAIMS ANY WARRANTY OF ANY OTHER KIND, INCLUDING ANY WARRANTY OF MERCHANTABILITY OR FITNESS FOR A PARTICULAR PURPOSE.

EACH PURCHASER UNDERSTANDS THAT THE MAGTEK PRODUCT IS OFFERED AS IS. IF THIS PRODUCT DOES NOT CONFORM TO MAGTEK'S SPECIFICATIONS, THE SOLE REMEDY SHALL BE REPAIR OR REPLACEMENT AS PROVIDED ABOVE. MAGTEK'S LIABILITY, IF ANY, TO RESELLER OR TO RESELLER'S CUSTOMERS, SHALL IN NO EVENT EXCEED THE TOTAL AMOUNT PAID TO MAGTEK BY RESELLER UNDER THIS AGREEMENT. IN NO EVENT WILL MAGTEK BE LIABLE TO THE RESELLER OR THE RESELLER'S CUSTOMER FOR ANY DAMAGES, INCLUDING ANY LOST PROFITS, LOST SAVINGS OR OTHER INCIDENTAL OR CONSEQUENTIAL DAMAGES ARISING OUT OF THE USE OF OR INABILITY TO USE SUCH PRODUCT, EVEN IF MAGTEK HAS BEEN ADVISED OF THE POSSIBILITY OF SUCH DAMAGES, OR FOR ANY CLAIM BY ANY OTHER PARTY.

LIMITATION ON LIABILITY

EXCEPT AS PROVIDED IN THE SECTIONS RELATING TO MAGTEK'S LIMITED WARRANTY, MAGTEK'S LIABILITY UNDER THIS AGREEMENT IS LIMITED TO THE CONTRACT PRICE OF THE PRODUCTS.

MAGTEK MAKES NO OTHER WARRANTIES WITH RESPECT TO THE PRODUCTS, EXPRESSED OR IMPLIED, EXCEPT AS MAY BE STATED IN THIS AGREEMENT, AND MAGTEK DISCLAIMS ANY IMPLIED WARRANTY, INCLUDING WITHOUT LIMITATION ANY IMPLIED WARRANTY OF MERCHANTABILITY OR FITNESS FOR A PARTICULAR PURPOSE.

MAGTEK SHALL NOT BE LIABLE FOR CONTINGENT, INCIDENTAL, OR CONSEQUENTIAL DAMAGES TO PERSONS OR PROPERTY. MAGTEK FURTHER LIMITS ITS LIABILITY OF ANY KIND WITH RESPECT TO THE PRODUCTS, INCLUDING ANY NEGLIGENCE ON ITS PART, TO THE CONTRACT PRICE FOR THE GOODS.

MAGTEK'S SOLE LIABILITY AND BUYER'S EXCLUSIVE REMEDIES ARE STATED IN THIS SECTION AND IN THE SECTION RELATING TO MAGTEK'S LIMITED WARRANTY.

FCC WARNING STATEMENT

This equipment has been tested and found to comply with the limits for Class B digital device, pursuant to Part 15 of FCC Rules. These limits are designed to provide reasonable protection against harmful interference when the equipment is operated in a residential environment. This equipment generates, uses, and can radiate radio frequency energy and, if not installed and used in accordance with the instruction manual, may cause harmful interference to radio communications. However, there is no guarantee that interference will not occur in a particular installation.

FCC COMPLIANCE STATEMENT

This device complies with Part 15 of the FCC Rules. Operation of this device is subject to the following two conditions: (1) This device may not cause harmful interference. And (2) this device must accept any interference received, including interference that may cause undesired operation.

CANADIAN DOC STATEMENT

This digital apparatus does not exceed the Class B limits for radio noise for digital apparatus set out in the Radio Interference Regulations of the Canadian Department of Communications.

Le présent appareil numérique n'émet pas de bruits radioélectriques dépassant les limites applicables aux appareils numériques de la classe B prescrites dans le Règlement sur le brouillage radioélectrique édicté par le ministère des Communications du Canada.

UL/CSA

This product is recognized per Underwriter Laboratories and Canadian Underwriter Laboratories 1950.

TABLE OF CONTENTS

SECTION 1. OVERVIEW -----	1
FEATURES-----	1
ACCESSORIES-----	1
SPECIFICATIONS-----	2
SECTION 2. INSTALLATION -----	3
REQUIREMENTS-----	3
PROCEDURE-----	3
SECTION 3. OPERATION -----	5
CHECK READING PROCEDURE-----	5
CARD SWIPE PROCEDURE-----	5
LED INDICATORS-----	6
SECTION 4. COMMANDS -----	7
INSTA-CHANGE CHECKS-----	7
PC PROGRAM-----	7
COMMAND FORMAT-----	7
SWA - SWITCH A COMMAND-----	8
SWA PARAMETERS-----	9
Baud Rate.....	9
Data and Parity.....	9
CTS/DSR.....	9
Number of Stop Bits.....	9
Intercharacter Delay.....	9
SWB - SWITCH B COMMAND-----	10
SWB PARAMETERS-----	11
Control Characters and MICR Data.....	11
Control Characters and Card Data.....	11
Communication Modes.....	11
Send Data After Error.....	12
Send Status After Data.....	12
SWC - SWITCH C COMMAND-----	13
SWC PARAMETERS-----	14
CMC-7 Character Set.....	14
Invalid Command Response.....	14
Active RTS.....	14
FC - FORMAT CHANGE COMMAND-----	14
VR - VERSION COMMAND-----	15
SA - SAVE COMMAND-----	15
RS - RESET COMMAND-----	15
APPENDIX A. FORMAT LIST -----	17
APPENDIX B. CHECK READING -----	33
E13-B CHARACTER SET-----	33
CMC-7 CHARACTER SET-----	33
CHECK LAYOUTS-----	34
MICR FIELDS-----	35
1-Transit Field.....	35
2-On-Us Field.....	35
3-Amount Field.....	36
4-Auxiliary On-Us Field.....	36
APPENDIX C. TROUBLESHOOTING GUIDE -----	37
REQUIREMENTS-----	37
SET-UP-----	37
APPENDIX D. PINPAD INTERFACE TO MICR READER -----	45
APPENDIX E. INTERFACE CABLE PIN LISTS -----	47

FIGURES

Figure 1-1. MAXI MICR RS232 with 2-Track MSR ----- viii
 Figure 3-1. Check Orientation----- 5
 Figure B-1. Personal Checks----- 34
 Figure B-2. Business Checks ----- 35
 Figure C-1. Sensor Location ----- 43
 Figure D-1. PINPad RJ Socket ----- 45

TABLES

Table 1-1. Specifications ----- 2
 Table 3-1. LED indicators ----- 6
 Table 4-1. SWA Command ----- 8
 Table 4-2. SWB Command ----- 10
 Table 4-3. Control Characters ----- 11
 Table 4-4. Error and Status Codes ----- 12
 Table 4-5. SWC Command ----- 13
 Table B-1. CMC-7 Nonnumeric Characters ----- 34
 Table D-1. PINPad RJ Socket ----- 46
 Table E-1. DB25 Interface Cable Pin List ----- 47
 Table E-2. Adapter Cable, DB25 to DB9, Pin List----- 47

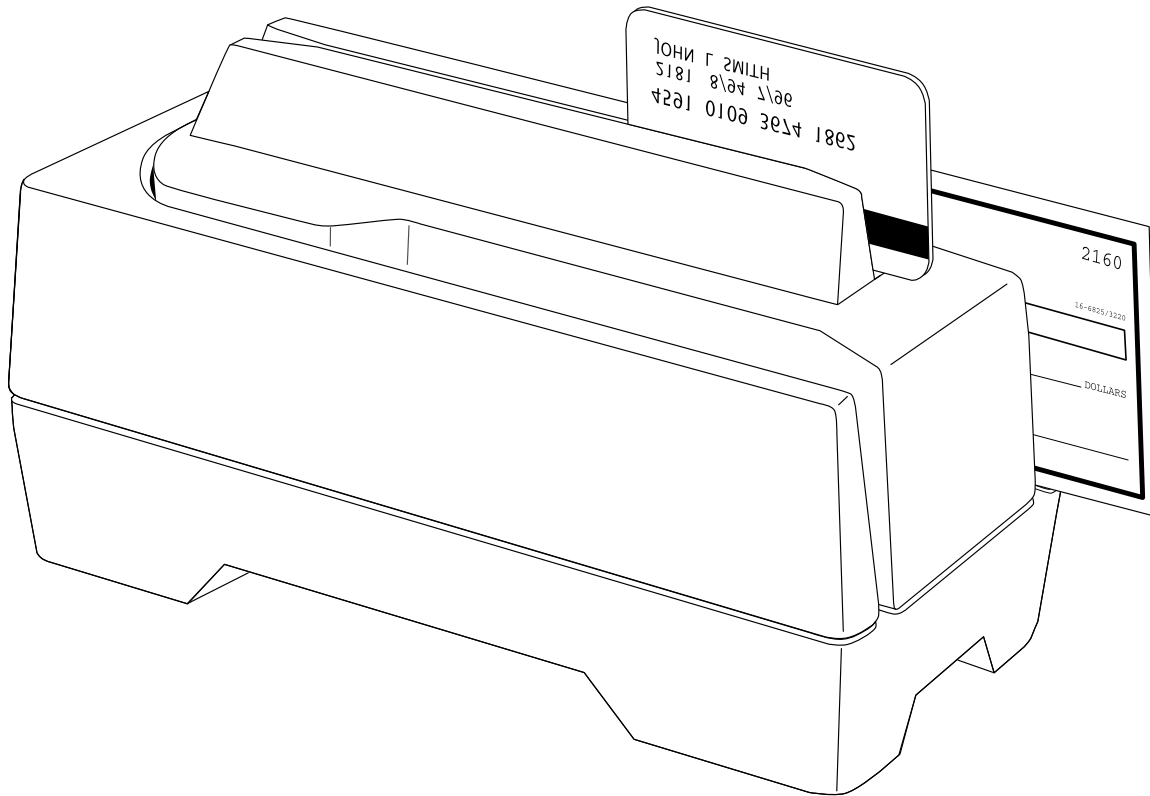

Figure 1-1. MAXI MICR RS232 with 2-Track MSR

SECTION 1. OVERVIEW

The MAXI MICR RS232 With Optional 2-Track MSR is both a MICR (Magnetic Ink Character Recognition) Check Reader and an MSR (Magnetic Stripe Reader).

The MICR Reader, in a typical application, reads the magnetic data encoded on the bottom of checks or magnetic stripe cards and transmits this data to a Host device. The Host device then uses a specific authorization or verification process to validate a business transaction.

The use of the MICR Reader improves accuracy and speed because there is no manual data entry; therefore there are no keying errors or unwanted delays.

The MICR Reader will communicate with the Host system using a standard RS-232 interface. All data is transmitted as ASCII characters (See Appendix F). The MICR Reader has the capability of supporting some hardware handshaking signals. (See Section 4, Commands.)

FEATURES

- Available with MICR Reader only or with 2-Track MSR (interface cable included – DB25 female connector to PC).
- Automatic parsing of MICR fields: transit, account, etc.
- Extensive list of formats to transmit MICR data.
- Optional error/status reporting for check reading.
- Reads E13-B and CMC-7 MICR fonts.
- In addition to the RS-232 interface, the MICR Reader is also available with other interfaces.

ACCESSORIES

Accessories available for the MICR Reader are as follows:

- Adapter Cable, DB25 male to DB9 female, Part Number 22017502
- AC Power Adapter with Cable, 120VAC to 12 VAC, 1 Amp, Part Number 64300050
- SET-MICR Demo Program, Part Number 22000020
- MICR Reader Cleaning Card, Part Number 96700006
- Sample Checks, Part Number 96530005

MAXI MICR RS232 with 2Track MSR

- Encrypting PINPad and Cable, Part Number 30015040 (See Appendix D)
- Encrypting PINPad Specification, Part Number 99815042
- Nonencrypting PINPad and Cable, Part Number 30015021 (See Appendix D)
- Nonencrypting PINPad Technical Description, Part Number 99833004

SPECIFICATIONS

Table 1-1 lists the specifications for the MICR Reader.

Table 1-1. Specifications

OPERATING	
Reference Standards	ISO/CDL/AAMVA
Power Input	120 VAC, 50/60 Hz
Output Signal Levels	12 VAC, 1 Amp
Check Read/Decode/Transit Time	1 second
MICR fonts supported	E13-B CMC-7
MSR supported	Tracks 1 and 2
MECHANICAL	
Dimensions	Length 9.25", Width 4.0", Height 4.7"
Weight:	3.75 lbs. MSR and Adapter included
Cable length	6'
Connectors	DB25 female
ENVIRONMENTAL	
Temperature	
Operating	0°C to 50°C (32°F to 122°F)
Storage	-30°C to 70°C (-22°F to 158°F)
Humidity	
Operating	10% to 90% noncondensing
Storage	Up to 100% noncondensing

SECTION 2. INSTALLATION

The installation for the MICR Reader is as follows:

REQUIREMENTS

The following is required for the Installation:

- MAXI MICR RS232 With Optional 2-Track MSR (interface cable included – DB25 female connector to PC).
- AC Power Adapter with Cable, 120VAC to 12 VAC, 1 Amp, Part Number 64300050

PROCEDURE

Perform the following steps:

1. On the interface cable connect the DB25 connector to the PC. If the adapter cable is required for a DB9 serial port, connect the adapter cable to the DB25 and the DB9 to the PC. The pin lists for these connectors are shown in Appendix E.
2. On the AC power adapter, connect the jack to the plug on the MICR Reader.
3. On the AC power adapter, connect the plug to the wall outlet.
4. The LED indicator on the MICR Reader should turn on to a steady green. The LED indicator is located below the slot where the check is first inserted for reading.

Caution

Do not place the MICR Reader within 6 inches of a computer monitor or power supply. These devices may cause undesirable interference with the check reading operation.

SECTION 3. OPERATION

This section contains check and card reading procedures and LED indicator states.

CHECK READING PROCEDURE

1. Orient the check so the MICR line is down and the printed side faces the center on the MICR Reader as shown in Figure 3-1.

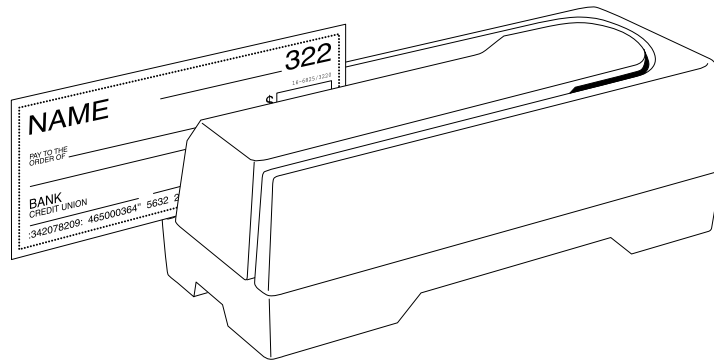

Figure 3-1. Check Orientation

2. Drop the check so the leading edge is in the open slot.
3. When the MICR Reader detects the presence of the check, the motor will turn on. At this time gently urge the check forward until the unit grabs the check. When this happens, release the check. The check will then be transported around the check path and will exit through the other side.
4. After the check is read, the MICR Reader will transmit the data as specified by the parameters described in Section 4, Commands.

CARD SWIPE PROCEDURE

The card may be swiped through the MSR in either direction, but the magnetic stripe must be oriented in only one direction as shown in Figure 1-1. The MSR will transmit raw card data (“as is” on the card) for all tracks.

LED INDICATORS

Table 3-1 describes the LED indicator conditions for check and card reading operations. The LED indicator is located below the slot where the check is first inserted for reading.

Table 3-1. LED indicators

LED INDICATOR	DESCRIPTION
OFF	Power off
SOLID GREEN	Ready to read check or card
OFF → SOLID RED	Check or card read error
OFF → SOLID GREEN	Good read
FLASH GREEN	Needs initialization*
FLASH RED/GREEN	Data sensor blocked (motor does not run)*
FLASH RED	Motor sensor blocked (motor does not run)*
FLASH GREEN FAST	Monitor mode (factory use only)*

*Refer to "Appendix C. Troubleshooting Guide."

SECTION 4. COMMANDS

This section describes the use of commands and programmable options available for the MICR Reader.

Note

All options described below can be factory set as specified by the user when ordering.

To execute the MICR Reader commands, either one of two methods is required: Insta-Change checks or a PC with a program that provides access to a serial communications (COMM) port.

INSTA-CHANGE CHECKS

The first method is the use of Insta-Change checks, which is a more practical way of setting up the MICR Reader for most applications. The Insta-Change check is a MICR encoded document that contains commands and options used to reset the parameters of the MICR Reader. Multiple commands and options may be contained on one Insta-Change check. When used, the Insta-Change checks are run through the MICR Reader the same as a standard check, and the options to be used are automatically selected. To obtain Insta-Change checks, notify a MagTek representative and specify what options will be used. To operate Insta-Change checks, install the MICR Reader as described in Section 2, and watch the LED indicator. When the Insta-Change check is run through the MICR Reader and read successfully, the LED indicator will blink green. If the LED indicator turns red, the read is not successful. Try again or use a different Insta-Change check.

PC PROGRAM

The second method, the PC program, may be MagTek's SET-MICR Demo program, or any other user provided PC program that permits access to the COMM port. With the SET-MICR program, commands may be selected from menus, but with any other program the command data is entered manually (typed) into the system. Whether SET-MICR, or any other program is used, the PC and the MICR Reader must be set to the same communication parameters (baud rate, parity, stop bits, etc.)

COMMAND FORMAT

When the commands are entered manually, they must use the following format:

[COMMAND] [DATA] <CR>

where:

- [**COMMAND**] is 2 or 3 alpha characters.
- [**Data**] is optional as described below for each command.
- <**CR**> is always required.
- All characters are ASCII
- No spaces, brackets, or angle brackets required.

SWA - SWITCH A COMMAND

The SWA command controls the communication parameters, shown in Table 4-1. The data for this command consists of 8 ASCII bits (“0” = hex 30 and “1” = hex 31).

Table 4-1. SWA Command

BITS								PARAMETERS
7	6	5	4	3	2	1	0	
					0	0	0	Reserved
					0	0	1	Baud Rate: 300
					0	1	0	Baud Rate: 600
					0	1	1	Baud Rate: 1200
					1	0	0	Baud Rate: 2400
					1	0	1	Baud Rate: 4800
					1	1	0	Baud Rate: 9600
					1	1	1	Baud Rate: 19200
			0	0				Data and Parity: 8, None
			0	1				Data and Parity: 7, Mark(1)
			1	0				Data and Parity: 7, Even
			1	1				Data and Parity: 7, Odd
		0						CTS/DSR: Use
		1						CTS/DSR: Ignore
	0							Number of Stop Bits: 1
	1							Number of Stop Bits: 2
0								Intercharacter Delay: No
1								Intercharacter Delay: Yes

To execute, send the SWA command as follows:

SWA 01010101<CR> (with data)
 or
SWA <CR> (without data)

When sending data, all 8 bits must be provided. The MICR Reader will execute the command but it will not reply. To make this command permanent, use the SA (Save) command described at the end of this section.

If no data is sent, the MICR Reader responds with the current settings for SWA.

Note

The new settings for the serial port will not become effective until the RS (Reset) command is executed. The Reset command is described at the end of this section.

SWA PARAMETERS

The SWA functions are listed in Table 4-1 and described below.

Baud Rate

The baud rate is one of seven speeds at which the MICR Reader communicates with the Host. The lowest speed is 300 baud, and the highest is 19200.

Data and Parity

The number of data bits and the parity bit are interrelated. If even, odd, or mark parity is selected, the MICR Reader will use seven data bits per byte with one parity bit. If a parity of none is selected, the MICR Reader will use eight data bits per byte.

CTS/DSR

When CTS/DSR (Clear to Send/Data Set Ready) is set to IGNORE, the MICR Reader sends data to the Host without waiting for the CTS and DSR signals to be active. When CTS/DSR is set to USE, the MICR Reader waits for the CTS and DSR signals to be active before sending data.

Number of Stop Bits

The number of stop bits is either 1 or 2. Normally, one stop bit is used for most applications. Two stop bits are used to allow extra time for slower Host equipment.

Intercharacter Delay

The intercharacter delay is used to increase the time between characters transmitted from the MICR Reader. The time is increased to 13 milliseconds. This parameter affects character rate but not baud rate (i.e., each character takes the same time to transmit but the time between characters is increased).

SWB - SWITCH B COMMAND

The SWB command controls the message format, shown in Table 4-2. The data for this command consists of 8 ASCII bits (“0” = hex 30 and “1” = hex 31).

To execute, send the SWB command as follows:

SWB 01010101<CR> (with data)

or

SWB <CR> (without data)

When sending data, all 8 bits must be provided. The MICR Reader will execute the command but it will not reply. The new settings become effective immediately. To make this command permanent, use the command SA (Save) described at the end of this section.

If no data is sent, the MICR Reader responds with the current settings for SWB.

Table 4-2. SWB Command

BIT								PARAMETERS
7	6	5	4	3	2	1	0	
							0	<LF>: No
							1	<LF>: Yes
						0		<CR>: No
						1		<CR>: Yes
					0			<ETX>: No
					1			<ETX>: Yes
				0				<ESC>: No
				1				<ESC>: Yes
			0					<STX>: No
			1					<STX>: Yes
		0						Send Data After Error?: No
		1						Send Data After Error?: Yes
	0							Send Status After Data?: No
	1							Send Status After Data?: Yes
0			0	0	0	0	0	Comm Mode: 0 - Data Only
1			0	0	0	0	0	Comm Mode: 1 - Data <CR>
0			0	0	0	0	1	Comm Mode: 2 - Data -<LF>
0			0	0	0	1	1	Comm Mode: 3 - Data -<CR><LF>
0			0	1	0	0	0	Comm Mode: 4 - <ESC> Data
0			0	1	0	1	0	Comm Mode: 5 - <ESC> Data<CR>
0			1	0	1	0	0	Comm Mode: 6 - <STX> Data<ETX>
1			0	0	0	0	1	Comm Mode: 7 - <STX>Data<ETX><LRC>

SWB PARAMETERS

The SWB functions are listed in Table 4-2 and described below.

Control Characters and MICR Data

Control Characters may be added to the MICR data message. The characters are always in the following locations:

<STX> <ESC> data <ETX> <CR> <LF>

The control characters, descriptions, and hex values are shown in Table 4-3.

Table 4-3. Control Characters

CONTROL CHARACTER	DESCRIPTION	HEX VALUE
<STX>	Start of Text	02
<ESC>	Escape	1B
<ETX>	End of Text	03
<CR>	Carriage Return	0D
<LF>	Line Feed	0A

For example, if <STX> and <CR> are set to YES, the message from the MICR Reader will look like this:

MICR Data: <STX>data<CR>

Control Characters and Card Data

The control characters are also available for card data but they are applied to each track individually. For example, if the <STX> and <ETX> options are set to YES, the card data message is transmitted as follows:

Card Data: <STX>[TK1 data]<ETX><STX>[TK2 data]<ETX><STX>[TK3 data]<ETX>

Communication Modes

The selection of comm modes is a quick way of selecting multiple Control Characters. For instance, to send a carriage return/line feed pair after the data, you can specify Comm Mode 3.

Comm Mode 7, also known as Packet Mode, calculates an LRC (Longitudinal Redundancy Check), and appends it to the data message. Also, if a <NAK> (hex 15) character is received in this mode, the MICR Reader will resend the last message.

Send Data After Error

The request Send Data After Error specifies whether the MICR Reader will return data to the Host after a read error. If YES is selected and the MICR Reader detects a read error, the MICR Reader will still send the data back to the Host. If NO is selected and the MICR Reader finds an error, it will discard the data and nothing will be sent. The error conditions are listed in Table 4-4.

Send Status After Data

The Send Status After Data option makes the MICR Reader append a two-digit error/status code to the end of the MICR data. For most formats (See Appendix A), the error/status code will always be preceded by a forward slash (/). The error/status codes are listed in Table 4-4.

For example, if a Canadian check (code 08) is read and had no errors, and the MICR data is “1234567890”, then the message from the MICR Reader will look like this:

MICR Data: 1234567890/08

The status code is always at the end of the data, not the end of the message. For example, using the above conditions, with the message format set to send <STX> and <ETX>, the message from the MICR Reader will look like this:

MICR Data: <STX>1234567890/08<ETX>

Table 4-4. Error and Status Codes

PRIORITY	CODE	TYPE	DESCRIPTION
9	01	Error	No MICR data: no transit and no account found
8	09	Status	Mexican check
7	08	Status	Canadian check
6	05	Error	Transit error: No transit, bad character, bad length, bad check digit
5	07	Error	Account error: No account, bad character
4	04	Error	Check # error: Bad character in check number
4	04	Status	No check number
3	03	Status	Low MICR signal, good read
2	10	Status	Business check
1	11	Status	Amount field present
0	00	Status	Good read

Notes:

- The LED indicator will turn red on all error conditions.
- The absence of a check number is not considered an error.
- If a multiple error condition occurs, the error or status code with the highest priority is reported.
- All unreadable MICR characters are transmitted as an “?” ASCII character (hex 3F), except for Format 00xx (See Appendix A).

SWC - SWITCH C COMMAND

The SWC command controls miscellaneous functions, shown in Table 4-5. The data for this command consists of 8 ASCII bits (“0” = hex 30 and “1” = hex 31).

To execute, send the SWC command as follows:

SWC 01010101<CR> (with data)
 or
SWC <CR> (without data)

When sending data, all 8 bits must be provided. The MICR Reader will execute the command but it will not reply. The new settings become effective immediately. To make this command permanent, use the SA (Save) command described at the end of this section.

If no data is sent, the MICR Reader responds with the current settings for SWC.

Table 4-5. SWC Command

BITS								PARAMETERS
7	6	5	4	3	2	1	0	
							0	CMC-7 Character Set: No
							1	CMC-7 Character Set: Yes
					0	0		Invalid Commands: ?<CR>
					0	1		Invalid Commands : No Reply (Header Required)*
					1	0		Invalid Commands: No Reply (No Header Required)
					1	1		Ignore all Commands
				0				Active RTS: No
				1				Active RTS: Yes
0	0	0	0					These bits are always set to 0

*Header Required means all commands must be preceded by a GS character (Hex 1D).

SWC PARAMETERS

The SWC functions are listed in Table 4-5 and described below.

CMC-7 Character Set

If NO is selected the MICR Reader will only read E13-B characters. When YES is selected, the MICR Reader will read both CMC-7 and E13-B characters (see Appendix B). However, the MICR Reader will only output raw data ("as is" on the check) for both types of characters.

Invalid Command Response

Invalid command response is the action the MICR Reader takes upon receipt of a command it does not recognize. It can also be used to stop the MICR Reader from receiving any more commands.

The first option “?**CR**” is the default. If the MICR Reader receives an unrecognized command, it will return a question mark and carriage return to the Host. The MICR Reader will then return to an idle state and wait for further commands or check/credit card reads.

For the second option, “no reply - header required,” the MICR Reader will only execute commands preceded by a GS ASCII character (hex 1D). All other commands will be ignored. Also, the MICR Reader will not reply to invalid commands.

For the third option, “no reply,” the MICR Reader will execute all valid commands, but it will not reply to invalid commands.

The fourth option, “ignore all commands,” causes the MICR Reader to ignore any further commands. Even the SA (Save) command is ignored and therefore this fourth option is only temporary. To make this option permanent or to reset it, you must use an Insta-Change check.

Active RTS

When this function is set to YES, the MICR Reader will raise RTS and wait 5 seconds for CTS to become active before sending any data. If the 5 seconds expire and CTS is not active, the data message will be discarded and nothing will be sent

FC - FORMAT CHANGE COMMAND

Formats are used by the MICR Reader to process and transmit the MICR fields. The format command allows the selection of a format from the Format List, Appendix A. The data for this command consists of 4 digits (ASCII characters 0-9). To execute, send the command as follows:

FC 6600<CR> (with data)

or

FC <CR> (without data)

When sending data, all 4 digits must be provided. The MICR Reader will execute the command but it will not reply. The new settings become effective immediately. To make this command permanent, use the SA (Save) command described below.

If no data is provided, the MICR Reader will respond with the current format number.

VR - VERSION COMMAND

The Version command gives the current software revision in the MICR Reader. To execute, send the VR command followed by a carriage return as follows:

VR<CR>

The MICR Reader responds as follows:

MICR data: [software revision]<CR>

SA - SAVE COMMAND

All changes are considered temporary until the Save command is executed. The Save command saves all changes to the MICR Reader memory and makes them permanent. The MICR Reader will execute the command but it will not reply. To execute, send the SA command followed by a carriage return as follows:

SA<CR>

RS - RESET COMMAND

The Reset command resets the MICR firmware to the normal operating state of waiting for a check or card to be read. The command also resets the serial port to the most recent settings provided by the SWA command. To execute, send the RS command followed by a carriage return as follows:

RS<CR>

APPENDIX A. FORMAT LIST

For check reading, the MICR Reader provides the flexibility to format the MICR fields and build a specific output string that will be transmitted to the Host. These output strings are referred to as formats. The Reader has a built-in list of formats (described below) from which the user may select one to become the active format every time a check is read. The formats may be selected using the FC command (Section 4, Commands) or Insta-Change checks provided by MagTek.

Each format is assigned a 4-digit number. The first two digits indicate the format number, and the last two digits are specific parameters used for various functions by each format. For example, in format "0415", the "04" refers to format number 4 and the 15 refers the maximum number of characters allowed for the account field.

Note

*The formats listed in this section apply only to U.S. and Canadian checks.
The MICR line on checks from other countries will not be broken or
parsed as described in these formats.*

A complete description for each format follows.

Fmt 00xx: Raw Data Format - sends the entire MICR line - where:

xx - specify what symbol set to use. Choose from the table
Add xx + 16 - change multiple spaces to one space
Add xx + 32 - Remove all spaces

Examples:

```
MICR LINE:  T122000218T 1234 5678 9U 1321
             FC0001 - t122000218t 1234 5678 9o 1321
(+16) FC0017 - t122000218t 1234 5678 9o 1321
(+32) FC0033 - t122000218t123456789o1321.
```

xx	Transit	On-Us	Amount	Dash	Error
00	T	U	\$	-	?
01	t	o	a	d	?
02	T	O	A	D	?
03	T	U	\$	-	*
04	T	U	\$	0	?
05	T	U	\$	0	*
06	t	o	a	0	?
07	T	U	\$	none	?

MAXI MICR RS232 with 2-Track MSR

Fmt 01xx: Parsed Text Format

FC0100 - Parsed text with dashes
FC0101 - Parsed text, replace dashes with "d"
Field Labels - TR-transit, AC-account #, CK-check #, AM-amount, TP-tpc,
EP-epc
Example: - PTTR444455556;AC 999-222-3;CK11045

Fmt 02xx: Parsed Text Format with Error Labels

FC0200 - Parsed text with dashes
FC0201 - Parsed text, replace dashes with "d"
Error Labels - PE-parsed error, NE-no error, TR-transit error,
CK-chk # error, TC-transit check digit error,
AM-amount error, OU-on us/account# error, TP-tpc error
Examples: - PTTR444455556;AC999-222-3;CK11045/PENE
- PTTR111?11111;AC123456/PETR ("?" = unreadable character)

Fmt 03xx: [acct #]

- [acct #]: - maximum of xx characters; when xx=00 all characters are sent
- keep spaces and dashes

Fmt 04xx: [acct #]

- [acct #]: - maximum of xx characters; when xx=00 all characters are sent
- remove spaces and dashes

Fmt 05xx: [acct #]

- [acct #]: - maximum of xx characters; when xx=00 all characters are sent
- replace spaces and dashes with zeros

Fmt 06xx: [acct #]

- [acct #]: - always xx characters, zero filled;
when xx=00 all characters are sent
- replace spaces and dashes with zeros

Fmt 07xx: [acct #]

- [acct #]: - always xx characters, zero filled;
when xx=00 all characters are sent
- remove spaces and dashes

Fmt 08xx: [transit] [acct #]

- [transit]: - all characters in the field
- keep dashes
- [acct #]: - maximum of xx characters; when xx=00 all characters are sent
- remove spaces and dashes

Fmt 09xx: [transit] [acct #]

- **[transit]:** - all characters in the field
- keep dashes
- **[acct #]:** - maximum of xx characters; when xx=00 all characters are sent
- replace spaces and dashes with zeros

Fmt 10xx: [transit] [acct #]

- **[transit]:** - all characters in the field
- keep dashes
- **[acct #]:** - always xx characters, zero filled;
when xx=00 all characters are sent
- replace spaces and dashes with zeros

Fmt 11xx: [transit] 'T' [acct #] 'A' [check #]

- **[transit]:** - all characters in the field
- keep dashes
- **[acct #]:** - maximum of xx characters; when xx=00 all characters are sent
- remove spaces and dashes
- **[check #]:** - all characters in the field

Fmt 12xx: [transit] 'T' [acct #] 'A' [check #]

- **[transit]:** - all characters in the field
- keep dashes
- **[acct #]:** - maximum of xx characters; when xx=00 all characters are sent
- remove spaces and dashes
- **[check #]:** - always 6 characters, zero filled

Fmt 13xx: [transit] 'T' [acct #] 'A' [check #] '000'

- **[transit]:** - all characters in the field
- keep dashes
- **[acct #]:** - maximum of xx characters; when xx=00 all characters are sent
- remove spaces and dashes
- **[check #]:** - always 6 characters, zero filled

MAXI MICR RS232 with 2-Track MSR

Fmt 14xx: [transit] [acct #] [check #]

- **[transit]:** - all characters in the field
- keep dashes
- **[acct #]:** - maximum of xx characters; when xx=00 all characters are sent
- remove spaces and dashes
- **[check #]:** - always 6 characters, zero filled

Fmt 15xx: [bank #] [acct #]

- **[bank #]:** - all characters in the field
- keep spaces and dashes
- **[acct #]:** - maximum of xx characters; when xx=00 all characters are sent
- remove spaces and dashes

Fmt 16xx: [bank #] [chk dgt] [acct #]

- **[bank #]:** - all characters in the field
- keep spaces and dashes
- **[chk dgt]:** - all characters (one character long)
- **[acct #]:** - maximum of xx characters; when xx=00 all characters are sent
- remove spaces and dashes

Fmt 17xx: [transit] [acct #]

- **[transit]:** - all characters in the field
- keep dashes
- **[acct #]:** - maximum of xx characters; when xx=00 all characters are sent
- keep spaces and dashes

Fmt 18xx: [acct #] "/" [check #]

- **[acct #]:** - maximum of xx characters; when xx=00 all characters are sent
- keep spaces and dashes
- **[check #]:** - all characters in the field

Fmt 19xx: [transit] [acct #] [check #]

- **[transit]:** - all characters in the field
- keep dashes
- **[acct #]:** - maximum of xx characters; when xx=00 all characters are sent
- replace spaces and dashes with zeros
- **[check #]:** - all characters in the field

Fmt 20xx: [transit] [acct #] <CR> [check #]

- **[transit]:** - all characters in the field
- keep dashes
- **[acct #]:** - maximum of xx characters; when xx=00 all characters are sent
- replace spaces and dashes with zeros
- **[check #]:** - all characters in the field

Fmt 21xx: [transit] [acct #] [check #]

- **[transit]:** - all characters in the field
- keep dashes
- **[acct #]:** - always xx characters, zero filled;
when xx=00 all characters are sent
- replace spaces and dashes with zeros
- **[check #]:** - all characters in the field

Fmt 22xx: [bank #] [acct #] [check #]

- **[bank #]:** - all characters in the field
- keep dashes
- **[acct #]:** - always xx characters, zero filled;
when xx=00 all characters are sent
- replace spaces and dashes with zeros
- **[check #]:** - all characters in the field

Fmt 23xx: [error #] [transit] [acct #] [check #] 'S'

- **[error #]:** - one digit, always present
- '0' read OK
- '1' read error: bad char, empty field, invalid length, validation
- **[transit]:** - always 9 characters, zero filled
- keep dashes
- **[acct #]:** - always xx characters, trailing spaces;
when xx=00 all characters are sent
- remove spaces and dashes
- **[check #]:** - always 6 characters, zero filled
- remove spaces and dashes

MAXI MICR RS232 with 2-Track MSR

Fmt 24xx: [transit] 'T' [acct #] 'A' [check #] 'C' [amount] '\$'

- [transit]: - all characters in the field
- keep dashes
- [acct #]: - maximum of xx characters; when xx=00 all characters are sent
- remove spaces and dashes
- [check #]: - always 6 characters, zero filled
- [amount]: - all characters in the field

Fmt 25xx: 'M' 'C' [transit] 'D' [acct #] 'E' [check #]

- [transit]: - all characters in the field
- remove dashes and keep spaces (contig spcs = 1 spc)
- if the field is empty, remove 'C'
- [acct #]: - include leading characters
- maximum of xx characters; when xx=00 all characters are sent
- remove dashes and keep all spaces
- if the field is empty, remove 'D'
- [check #]: - all characters in the field
- if the field is empty, remove 'E'

Fmt 26xx: [acct #]

- [acct #]: - work with characters in acct and transit fields
- a window of xx characters; xx must be greater than 00
- remove spaces and dashes

Fmt 27xx: [acct #]

- [acct #]: - work with characters in the acct field only
- a window of xx characters; xx must be greater than 00
- remove spaces and dashes

Fmt 28xx: [acct #]

- [acct #]: - work with characters in the acct field only
- a window of xx characters; xx must be greater than 00
- minimum of 6 digits, fill with zeros if necessary
- remove spaces and dashes

Fmt 29xx: 'C' '/' [transit] '/' [acct #] '/' [check #] '/' [status]

- [transit]: - all characters in the field
- keep dashes
- [acct #]: - maximum of xx characters; when xx=00 all characters are sent
- remove spaces and dashes
- [check #]: - maximum of 6 digits
- [status]: - this is a programmable option that must be enabled (See Table 4-4).

Fmt 30xx: [zero fill] [transit] [acct #]

- [zero fill]: - if length of (transit+account) is less than xx;
xx must be greater than 00
- [transit]: - all characters in the field
- remove dashes
- [acct #]: - all characters in the field
- remove spaces and dashes

Fmt 31xx: [transit] '/' [acct #] '/' [check #]

- [transit]: - all characters in the field
- remove dashes
- [acct #]: - maximum of xx characters; when xx=00 all characters are sent
- remove spaces and dashes
- [check #]: - maximum of 10 digits
- remove spaces and dashes
- if no check number, remove preceding slash ('/')

Fmt 3200: '^' [transit] '^' [acct #] '^' [check #] '^' [status]

- [transit]: - all characters in the field
- remove dashes
- [acct #]: - all characters in the field
- remove spaces and dashes
- [check #]: - all characters in the field
- remove spaces and dashes
- [status] : - this is a programmable option that must be enabled (See Table 4-4).

MAXI MICR RS232 with 2-Track MSR

Fmt 3300: '=' [transit] '=' [acct #] '=' [check #] '=' [status]

- [transit]: - all characters in the field
- remove dashes
- [acct #] : - maximum of 14 digits
- remove spaces and dashes
- [check #]: - maximum of 8 digits
- remove spaces and dashes
- [status]: - this is a programmable option that must be enabled (See Table 4-4).

Fmt 34xx: [transit] [acct #] [zero fill]

- [transit]: - all characters in the field
- remove dashes
- [acct #]: - all characters in the field
- remove spaces and dashes
- [zero fill]: - zero filled up to xx; xx must be greater than 00

Fmt 3500: MA [aux] B [epc] C [tran] D [acct] E [chk] F [tpc] G [amt]

This format is defined specifically for Target Test Checks. A description of the Target Test Check must be loaded in the exception table.

- [aux], [epc], [tran], [chk], [tpc], [amt]:
- all characters in the field
- keep spaces and dashes
- [acct]: - all characters in the field
- keep spaces and remove dashes

Fmt 36xx: Read OK : [transit] [acct #] [check #] '/'
Read error: '0' '/'

- [transit]: - all characters in the field
- remove spaces and dashes
- [acct #]: - maximum of xx characters; when xx=00 all characters are sent
- remove spaces and dashes
- [check #]: - always 6 characters, zero filled
- remove spaces and dashes

Fmt 37xx: [ABA] [chk dgt] [acct #]

- [ABA], [chk dgt]:
 - all characters in the field
 - keep spaces and dashes
- [acct #]:
 - work with characters in the acct field only
 - window of xx characters; xx must be greater than 00
 - remove spaces and dashes

Fmt 38xx: 'T' [transit] 'A' [acct #] 'C' [check #]

- [transit]:
 - all characters in the field
 - keep dashes
- [acct #]:
 - maximum of xx characters; when xx=00 all characters are sent
 - include leading characters
 - keep spaces and dashes
- [check #]:
 - all characters in the field

Fmt 39xx: [transit] <CR> [acct #]

- [transit]:
 - all characters in the field
 - remove dashes
- [acct #]:
 - maximum of xx characters; when xx=00 all characters are sent
 - remove spaces and keep dashes

Fmt 40xx: [country code] [transit] [acct #]

- [country code]:
 - '1' for US checks
 - '2' for Canadian checks
- [transit]:
 - all characters in the field
 - remove dashes
- [acct #]:
 - maximum of xx characters; when xx=00 all characters are sent
 - remove spaces and dashes

Fmt 4100: 'S' 'T' [transit] 'A' [acct #] 'C' [check #]

- [transit]:
 - all characters in the field
 - remove dashes
- [acct #]:
 - all characters in the field
 - place a slash ('/') after 10th character
 - if 10 characters or less, precede with a slash ('/')
 - remove spaces and dashes
- [check #]:
 - always 6 characters, zero filled
 - remove spaces and dashes

MAXI MICR RS232 with 2-Track MSR

Fmt 42xx: US check : [transit] [acct #]

Can check: '9' [transit] [acct #]

- [transit]: - all characters in the field
- remove dashes
- [acct #]: - always xx characters; zero filled;
when xx=00 all characters are sent.
- remove spaces and dashes

Fmt 43xx: [check #] <CR> <CR> [transit] <CR> [acct #]

- [check #]: - maximum of 6 digits
- remove spaces and dashes
- [transit]: - all characters in the field
- remove dashes
- [acct #]: - maximum of xx characters; when xx=00 all characters are sent
- remove spaces and dashes

Fmt 44xx: [transit] [acct #]

- [transit]: - all characters in the field
- if Canadian check, replace dash with a space
- [acct #]: - always xx characters, trailing spaces,
when xx=00 all characters are sent
- remove spaces and dashes

Fmt 45xx: [transit] <CR> [acct #] <CR> [check #]

- [transit]: - all characters in the field
- remove dashes
- [acct #]: - maximum of xx characters; when xx=00 all characters are sent
- remove spaces, dashes and leading zeros
- [check #]: - all characters in the field

Fmt 46xx: [transit] [acct #] [check #]

- [transit]: - all characters in the field
- remove dashes
- [acct #]: - always xx characters, zero filled;
when xx=00 all characters are sent
- remove spaces and dashes
- [check #]: - always 6 characters, zero filled
- remove spaces and dashes

Fmt 47xx: [transit] 'T' [acct #] 'A' [check #]

- [transit]: - all characters in the field
- remove dashes
- [acct #]: - maximum of xx characters; when xx=00 all characters are sent
- remove spaces and dashes
- [check #]: - all characters in the field

Fmt 48xx: [transit] 'T' [acct #] 'A'

- [transit]: - all characters in the field
- remove dashes
- [acct #]: - maximum of xx characters; when xx=00 all characters are sent
- remove spaces and dashes

Fmt 49xx: [transit] '/' [acct #] '/' [check #] '/' [check type]

- [transit]: - always 9 characters, zero filled
- remove dashes
- [acct #]: - maximum of xx characters; when xx=00 all characters are sent
- remove spaces and dashes
- [check #]: - maximum of 9 digits
- [check type]: - personal checks ('1'); commercial checks ('2')

Fmt 50xx: 'T' [transit] 'T' 'O' [acct #] 'O' [check #]

- [transit]: - all characters in the field
- remove dashes
- [acct #]: - maximum of xx characters; when xx=00 all characters are sent
- remove spaces and dashes
- [check #]: - all characters in the field

Fmt 51xx: '=' [transit] '=' [acct #] '='

- [transit]: - all characters in the field
- remove dashes
- [acct #]: - maximum of xx characters; when xx=00 all characters are sent
- remove spaces and dashes

MAXI MICR RS232 with 2-Track MSR

Fmt 52xx: 'T' [transit] 'T' [acct #] 'A' [check #]

- [transit]: - all characters in the field
- remove dashes
- [acct #]: - maximum of xx characters; when xx=00 all characters are sent
- remove spaces and dashes
- [check #]: - all characters in the field
- remove dashes and spaces

Fmt 53xx: '/' [transit] '/' [acct #] '/' [check #] '/' [tpc] '/' [status] '/'

- [transit]: - all characters in the field
- remove dashes
- [acct #]: - maximum of xx characters; when xx=00 all characters are sent
- remove spaces and dashes
- [check #]: - all characters in the field
- [tpc]: - all characters in the field
- [status]: - this is a programmable option that must be enabled (See Table 4-4)

Fmt 54xx: [transit] [acct #] [check #] [status]

- [transit]: - always 12 characters, zero filled
- remove dashes
- [acct #]: - always xx characters, zero filled;
when xx=00 all characters are sent
- remove spaces and dashes
- [check #]: - always 12 characters, zero filled
- remove dashes and spaces
- [status]: - this is a programmable option that must be enabled (See Table 4-4)

Fmt 55xx: 'C' '/' [acct #] '/' [transit] '/' [check #] '/' 000000000

- [acct #]: - always xx characters, zero filled;
when xx=00 all characters are sent
- remove spaces and dashes
- [transit]: - all characters in the field
- remove dashes
- [check #]: - always 6 characters, zero filled
- remove dashes and spaces

Fmt 56xx: [transit] <CR> [acct #] <CR> [check #] <CR> [amount]

- [transit]: - all characters in the field
- remove dashes
- [acct #]: - maximum of xx characters; when xx=00 all characters are sent
- remove spaces and dashes
- [check #]: - all characters in the field
- remove dashes and spaces
- [amount]: - all characters in the field
- remove dashes and spaces

Fmt 57xx: [acct #] <CR> [amount]

- [acct #]: - maximum of xx characters; when xx=00 all characters are sent
- remove spaces and dashes
- [amount]: - all characters in the field
- remove dashes and spaces

Fmt 58xx: [short transit] [acct #] ':'

- [transit]: - 3 rightmost characters
- remove dashes
- [acct #]: - maximum of xx characters; when xx=00 all characters are sent
- remove spaces and dashes

Fmt 59xx: [transit] [acct #] <TAB> [check #] [amount]

- [transit]: - all characters in the field
- remove dashes
- [acct #]: - maximum of xx characters; when xx=00 all characters are sent
- remove spaces and dashes
- [check #]: - always 9 characters, zero filled
- remove dashes and spaces
- [amount]: - all characters in the field
- remove dashes and spaces
- insert decimal point ('.') before 2nd rightmost digit

MAXI MICR RS232 with 2-Track MSR

Fmt 60xx: [transit] '/' [acct #] '/' [check #] '/' [check type]

- [transit]: - all characters in the field
- remove dashes
- [acct #]: - maximum of xx characters; when xx=00 all characters are sent
- remove spaces and dashes
- [check #]: - maximum of 10 characters
- remove spaces and dashes
- if no check #, remove preceding slash ('/')
- [check type]: - personal checks ('1'); commercial checks ('2')

Fmt 61xx: [transit] <TAB> [acct #] <TAB> [check #] <TAB>

- [transit]: - all characters in the field
- remove dashes
- [acct #]: - maximum of xx characters; when xx=00 all characters are sent
- remove spaces, dashes and leading zeros
- [check #]: - all characters in the field

Fmt 62xx: 'T' [transit] 'T' [acct #] 'A' [check #] 'S' [status]

- [transit]: - all characters in the field
- remove dashes
- [acct #]: - maximum of xx characters; when xx=00 all characters are sent
- remove spaces and dashes
- [check #]: - all characters in the field
- remove dashes and spaces
- [status]: - this is a programmable option that must be enabled (See Table 4-4).

Fmt 63xx: [transit] [acct #] [check #]

- [transit]: - all characters in the field
- remove dashes
- [acct #]: - maximum of xx characters; when xx=00 all characters are sent
- remove spaces and dashes
- [check #]: - always 4 characters, zero filled
- remove spaces and dashes

Fmt 64xx: [transit] [acct #] [check #] [amount]

- [transit]: - all characters in the field
- keep dashes
- [acct #]: - always xx characters, trailing spaces;
when xx=00 all characters are sent
- keep spaces and dashes
- [check #]: - always 6 characters (N is on quick-init check), trailing spaces
- remove spaces and dashes
- [amount]: - all characters in the field
- remove spaces and dashes
- insert decimal point ('.') before 2nd rightmost digit

Fmt 65xx: '!' [transit] '/' [acct #] '/' [check #] '/' [amount]

- [transit]: - all characters in the field
- remove dashes
- [acct #]: - maximum of xx characters; when xx=00 all characters are sent
- remove spaces and dashes
- [check #]: - all characters in the field
- remove dashes and spaces
- [amount]: - all characters in the field
- remove dashes and spaces

Fmt 66xx: [transit] [acct #] <CR> '7' '1' <CR>

- [transit]: - all characters in the field
- keep dashes
- [acct #]: - maximum of xx characters; when xx=00 all characters are sent
- remove spaces and dashes

Fmt 67xx: <CR> <CR> [check #]

- [check #] : - maximum of xx characters; when x=00 all characters are sent
- remove spaces and dashes

MAXI MICR RS232 with 2-Track MSR

Fmt 68xx: [transit] <TAB> [acct #] <TAB> [check #] <TAB> [amount] <TAB>

- [transit]: - all characters in the field
- remove dashes
- [acct #]: - maximum of xx characters; when xx=00 all characters are sent
- remove spaces and dashes
- [check #]: - all characters in the field
- remove dashes and spaces
- [amount]: - all characters in the field
- remove dashes, spaces and leading zeros
- insert decimal point ('.') before 2nd rightmost digit

Fmt 69xx: Read OK : [transit] [acct #] [check #]

Read error: '0' '/'

- [transit]: - all characters in the field
- remove dashes
- [acct #]: - always xx characters, trailing spaces;
when xx=00 all characters are sent
- remove spaces and dashes
- [check #]: - always 6 characters, zero filled
- remove dashes and spaces

Fmt 70: [transit] ',' [acct #] ',' [check #] ',' [amount]

- [transit]: - all characters in the field
- keep dashes
- [acct #]: - always N characters (N is on quick-init check), space filled
- remove spaces and dashes from the account
- [check #]: - always 8 characters, zero filled
- remove dashes and spaces
- [amount]: - all characters in the field
- remove dashes and spaces
- if amount is not present, remove last ','

Fmt 71: [acct #] '?' [check #]

- [acct #]: - work with a window of N characters in the acct field
- always N characters (N is on quick-init check), zero filled
- remove spaces and dashes
- [check #]: - maximum of 4 characters
- remove spaces and dashes

APPENDIX B. CHECK READING

The characters printed on the bottom line of commercial and personal checks are special. They are printed with magnetic ink to meet specific standards . These characters can be read by a MICR Reader at higher speeds and with more accuracy than manual data entry. Two MICR character sets are used world wide; they are: E13-B and CMC-7. The E13-B set is used in the US, Canada, Australia, United Kingdom, Japan, India, Mexico, Venezuela, Colombia, and the Far East. The CMC-7 set is used in France, Spain, other Mediterranean countries, and most South American countries.

E13-B CHARACTER SET

The MICR font character set E13-B includes digits 0 through 9 and four symbols. The numbers found on U.S. checks are of the E13-B character set. The numbers and symbols of E13-B are as follows:

1	6	
2	7	┆┆ Transit symbol
3	8	┆┆┆ Dash Symbol
4	9	┆┆ On-Us Symbol
5	0	┆┆ Amount Symbol

CMC-7 CHARACTER SET

The numbers and symbols of the CMC-7 character set are as follows:

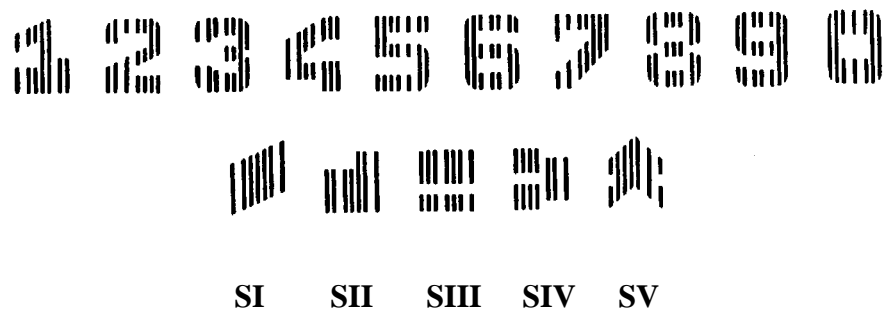

The nonnumeric CMC-7 characters are translated by the MICR Reader as shown in Table B-1.

Table B-1. CMC-7 Nonnumeric Characters

CMC-7 Character	MICR Reader Output
SI	A
SII	B
SIII	C
SIV	D
SV	E

CHECK LAYOUTS

Personal checks with MICR fields are shown in Figure B-1. Business checks are shown in Figure B-2. The digits 1 through 4 in the illustrations are described below under MICR Fields.

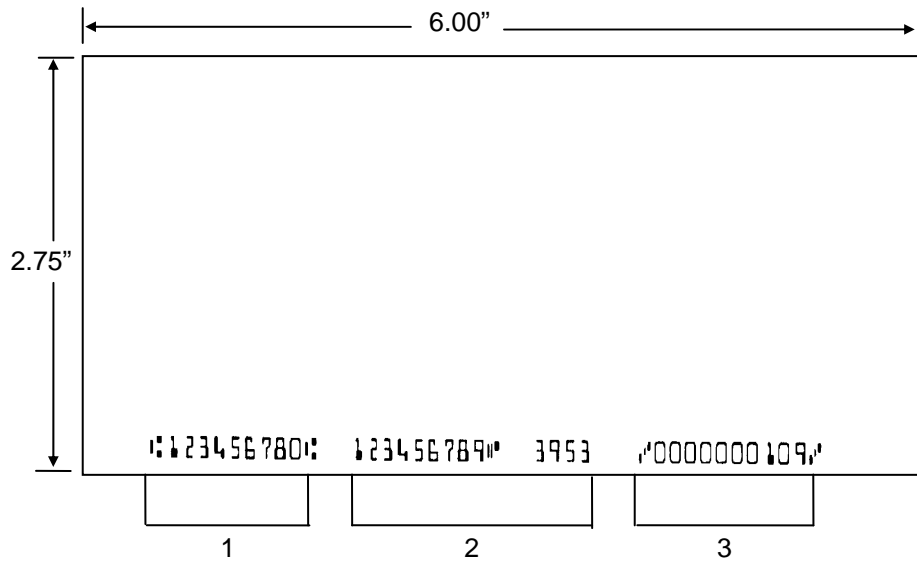

Figure B-1. Personal Checks

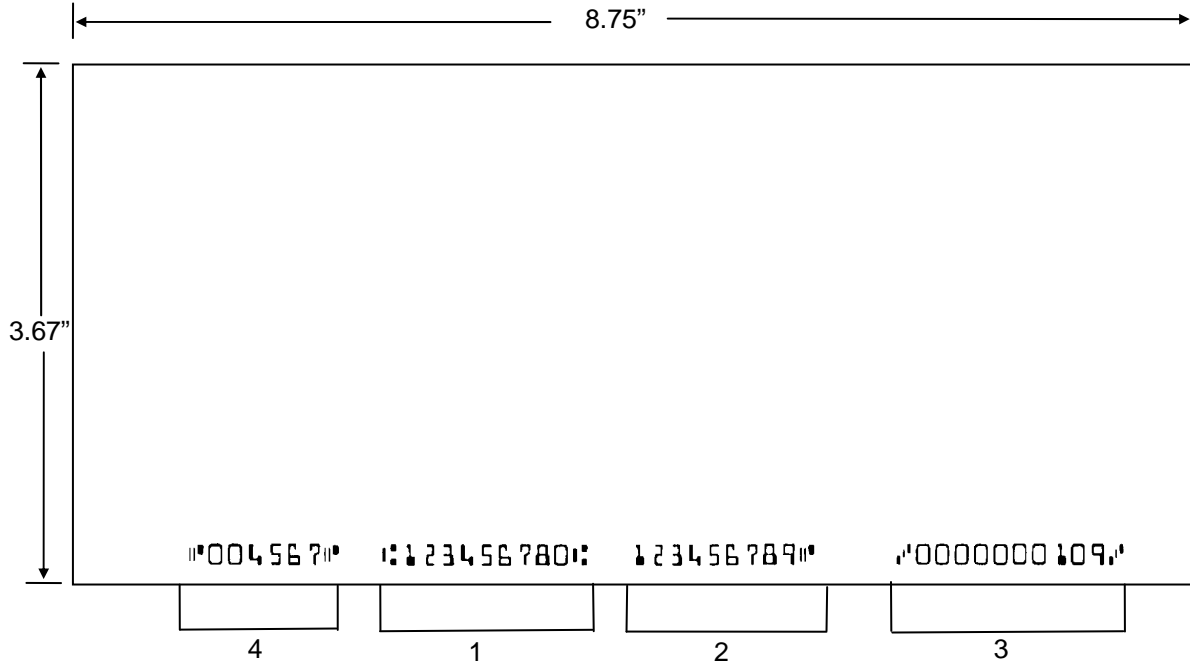

Figure B-2. Business Checks

MICR FIELDS

The numbers 1 through 4 refer to the numbers below the checks on the illustration and represent the 4 MICR fields.

1-Transit Field

The Transit field is a 9-digit field bracketed by two Transit symbols. The field is subdivided as follows:

- Digits 1-4 Federal Reserve Routing Number
- Digits 5-8 Bank ID Number (American Banking Association)
- Digit 9 Check Digit

2-On-Us Field

The On-Us field is variable, up to 19 characters (including symbols). Valid characters are digits, spaces, dashes, and On-Us symbols. The On-Us field contains the account number and may also contain a serial number (Check number) and/or a transaction code. Note that an On-Us symbol must always appear to the right of the account number.

3-Amount Field

The Amount field is a 10-digit field bracketed by Amount symbols. The field is always zero-filled to the left.

4-Auxiliary On-Us Field

The Auxiliary On-Us field is variable, 4-10 digits, bracketed by two On-Us symbols. This field is not present on personal checks. On business checks, this field contains the check serial number.

APPENDIX C. TROUBLESHOOTING GUIDE

REQUIREMENTS

- Personal Computer.
- AC adapter, P/N 64300050.
- SET-MICR program, P/N 22000020.
- Sample checks, P/N 96530005.
- A small bottle of compressed air.
- A cleaning card, P/N 96700006.

SET-UP

1. Plug the DB25 or DB9 connector into the PC.
2. Power on the MICR Reader.
3. Run the SET-MICR program on the PC.
4. Press <F9> to establish communication between the PC and the MICR Reader.
5. Start trouble-shooting procedure at Step 00.

00	Check LED
-----------	------------------

Check the status of the LED indicator:

- ◇ off, continue to step 01.
- ◇ green, continue to step 02.
- ◇ blinking red, continue to step 11.
- ◇ blinking green, continue to step 16.
- ◇ blinking red/green, continue to 12.
- ◇ red or orange, continue to step 17.

01	Check the Power to the MICR Reader
-----------	---

Possible causes for this problem are:

- AC adapter connection to outlet - make sure the AC adapter is securely connected to outlet on the wall or power strip.
- AC adapter connection to MICR Reader - make sure the AC adapter is securely connected to the power jack on the MICR Reader.
- Power strip - if using a power strip, make sure the strip is connected to outlet on the wall and the switch on the strip is turned on.
- AC adapter is defective - replace the AC adapter.

Determine if any of the conditions described above are true:

- ◇ If yes, rectify and continue to step 00.
- ◇ If no, continue to step 17.

02	Read a check
-----------	---------------------

Read a check through the MICR Reader:

- ◇ If the check is transported all the way around the check path, continue to step 03.
- ◇ If the check gets "stuck" in the check path, continue to step 10.
- ◇ If the motor does not turn on, continue to step 17.

03	Did PC receive data?
-----------	-----------------------------

After the check is read, did the PC receive any data?

- ◇ If yes, continue to step 04.
- ◇ If no, continue to step 05

04	Analyze data
-----------	---------------------

Analyze the data received by the PC:

- ◇ If the data is good, continue to step 15.
- ◇ If the data contains one or more '?', continue to step 06.
- ◇ If the data is missing characters, continue to step 07.
- ◇ If the data is garbled, continue to step 08.
- ◇ If the data is good but not what is expected, continue to step 09.

05	Verify parameters
-----------	--------------------------

Use SET-MICR to verify the following parameters:

- "Send Data After Error" - if this option is set to NO, the MICR Reader will not send any data after a read error. Use SET-MICR to change this option to YES.
- "Use CTS/DSR" - if this option is set to USE, the MICR Reader will not send any data unless the CTS and DSR signals are enabled. Use SET-MICR to change this option to IGNORE.

Determine if any of the conditions described above are true:

- ◇ If yes, rectify and continue to step 02.
- ◇ If no, continue to step 13.

06	Read error
-----------	-------------------

Possible causes for this problem are:

- Interference - the MICR Reader may be too close to a monitor, AC adapter or magnetic device. Move the MICRF Reader away from the source of interference.
- Printing problem - the check being read may not meet the requirements of the ANSI Standards. Use one the sample checks provided by MagTek .
- Feeding the check - do not hold on to the check as it goes around the path. Release the check immediately after the MICR Reader "grabs" it. Also, make sure that the front end is not tilted up while the check is being read.
- Foreign debris – power off the MICR Reader and try to push out any loose debris on the check path. Grab the cleaning card and force it through the check path (this is a manual process, the motor will not turn on). Try this procedure several times until the debris comes out. Power on the MICR Reader again.

MAXI MICR RS232 with 2-Track MSR

Determine if any of the conditions described above are true:

- ◇ If yes, rectify and continue to step 02.
- ◇ If no, continue to step 14.

07	Missing characters
-----------	---------------------------

Possible causes for this problem are:

- Character rate - the character rate at which the MICR Reader is transmitting data may be too fast for the PC. Use SET-MICR to set the "Inter-character Delay" option to YES.
- Feeding the check - When feeding the check, make sure that the MICR line is at the bottom and the printed side of the check is facing the MagTek logo on the MICR Reader.

Determine if any of the conditions described above are true:

- ◇ If yes, rectify and continue to step 02.
- ◇ If no, continue to step 08.

08	Communication parameters do not match
-----------	--

Verify that the communication parameters of the MICR Reader match the parameters of the PC. Use SET-MICR to verify/change the communication parameters.

Determine if the condition described above is true:

- ◇ If yes, rectify and continue to step 02.
- ◇ If no, continue to step 14.

09	Incorrect Format
-----------	-------------------------

Possible causes for this problem are:

- Incorrect Format Number - the current Check data format in the MICR Reader is not the desired format. Use SET-MICR to verify/change the format.
- Incorrect Message Format - the current Message format in the MICR Reader is not the desired format. Use SET-MICR to verify/change the Message format.

Determine if any of the conditions described above are true:

- ◇ If yes, rectify and continue to step 02.
- ◇ If no, continue to step 17.

10	Path is obstructed
-----------	---------------------------

Foreign debris is obstructing the check path:

- Loose debris - power off the MICR Reader and try to push out any loose debris on the check path. Grab the cleaning card and force it through the check path (this is a manual process, the motor will not turn on). Try this procedure several times until the debris comes out. Power on the MICR Reader.
- Wedged debris - the debris is wedged in and cannot be removed with the procedure described above.

Is the foreign debris removable?

- ◇ if yes, remove and continue to step 02.
- ◇ If no, continue to step 17.

11	Motor sensor is blocked
-----------	--------------------------------

The Motor sensor may be blocked by dust build-up or foreign debris (see Figure C-1). Use forced air to clean the sensor.

Power off the MICR Reader and then power on again, observe the LED indicator:

- ◇ If the LED indicator blinks red, continue to step 17.
- ◇ Any other LED indicator status, continue to step 00.

12	Data sensor is blocked
-----------	-------------------------------

The data sensor may be blocked (see Figure C-1). Try one or both of the following procedures:

- Forced air - use forced air to clean the sensor.
- Cleaning card - power off the MICR Reader and try to push out any loose debris on the check path. Grab the cleaning card and force it through the check path (this is a manual process, the motor will not turn on). Try this procedure several times until the debris comes out.

Power off the MICR Reader and then power on again, observe the LED indicator:

- ◇ If the LED indicator blinks red/green, continue to step 17.
- ◇ Any other LED indicator status, continue to step 00.

13	No MICR data detected
-----------	------------------------------

Possible causes for this problem are:

- No MICR characters - the ink used to print the MICR characters does not have magnetic properties. Try one of the sample checks provided by MagTek.
- Feeding the check - When feeding the check, make sure that the MICR line is at the bottom and the printed side of the check is facing the MagTek logo on the MICR Reader.

Determine if any of the conditions described above are true:

- ◇ If yes, rectify and continue to step 02.
- ◇ If no, continue to step 14.

14	Cable problem
-----------	----------------------

Possible causes for this problem are:

- Loose connection - the cable connector on the PC or the MICR Reader may be loose. Make sure that both connectors are tightly connected.
- Damaged cable - the connectors, pins or wires in the cable may be damaged. Replace cable.

Determine if any of the conditions described above are true:

- ◇ If yes, rectify and continue to step 02.
- ◇ If no, continue to step 17.

15	No problem found
-----------	-------------------------

The MICR Reader is operating properly. If you have additional concerns or requirements please contact your MagTek representative.

16	Read Insta-Change check
-----------	--------------------------------

Read Insta-Change check with the appropriate settings. Return to step 00. If condition persists, continue to step 17.

17	Return MICR Reader to MagTek
-----------	-------------------------------------

The MICR Reader has a problem that needs further analysis, testing, and possibly repair. Please contact the MagTek Help Desk at (451) 651-6800, and make arrangements to send the unit back to MagTek. Include a detailed description of the problem.

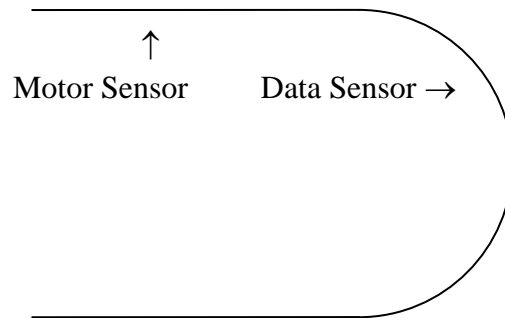

Figure C-1. Sensor Location

APPENDIX D. PINPAD INTERFACE TO MICR READER

The PINPad device connects to the 4-pin RJ socket on the MICR Reader. This socket is referred to as the PINPad port. This port uses the RS232 protocol at TTL voltage levels with settings fixed at 300 baud rate, 7 data bits and odd parity.

In a typical connection, the PINpad connects to the MICR Reader, and the MICR Reader connects to the Host. The MICR Reader serves as a communication bridge between Host and PINPad. It should be noted that the MICR Reader simply directs the data flow from the Host to the PINPad (and vice versa) and is never responsible for the PINPad operation. At all times, the Host is responsible for the control of the PINPad operation.

Connect the PINPad to the RJ socket on the MICR Reader. The RJ socket is shown in Figure D-1, and the pin descriptions are listed in Table D-1.

To communicate with the PINPad through the MICR Reader, all PINPad commands from the Host must be in the following format:

<STX>[PINPad Command]<ETX>

When the MICR Reader receives commands for the PINPad, the MICR Reader just passes the commands along to the PINPad.

In the same manner all PINPad data to the Host will be in the following format:

<STX>[PINPad Data]<ETX>

For further information on PINPad operation refer to the following documents:

- Encrypting PINPad Specification, Part Number 99815042
- Nonencrypting PINPad Technical Description, Part Number 99833004

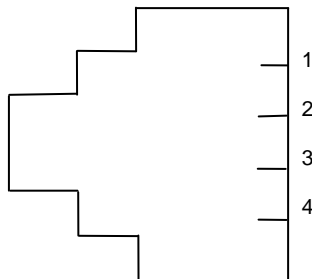

Figure D-1. PINPad RJ Socket

Table D-1. PINPad RJ Socket

PIN NUMBER	SIGNAL (MICR as Reference)	DESCRIPTION
2	GND	Ground
3	TXD	Transmitted Data, RS-232 Signal. Transmits data from the MICR to the PINPad.
1	RXD	Received Data, RS-232 Signal. Receives data from the PINPad to the MICR.
4	+5V	+5 volt DC Power

APPENDIX E. INTERFACE CABLE PIN LISTS

The pin list for the DB25 Interface Cable is shown in Table E-1, and the Adapter Cable, DB25 male to DB9 female, is shown in Table E-2.

Table E-1. DB25 Interface Cable Pin List

PIN	SIGNAL (Host as Reference)	DESCRIPTION
2	TXD	Transmitted Data. Transmits data from the Host to the MICR Reader.
3	RXD	Received Data. Receives data from the MICR Reader to the Host.
4	RTS	Request to Send. Sends a signal to the MICR Reader to indicate that the Host is ready to receive data.
5	CTS	Clear to Send. Receives a signal from the MICR Reader to indicate that the MICR Reader is ready to send data.
6 8	DSR DCD	Data Set Ready. Receives a signal from the MICR Reader to indicate that the MICR Reader is active, i.e., power is on.
7	GND	Ground
20	DTR	Data Terminal Ready. Transmits a signal to the MICR Reader to indicate that the Host is active, i.e., power is on.

Table E-2. Adapter Cable, DB25 to DB9, Pin List

DB25 male	DB9 female
SHELL (GND) 1	SHELL (GND)
8	1
3	2
2	3
20	4
7	5
6	6
4	7
5	8
22	9

APPENDIX F. ASCII CODES

The following is a listing of the ASCII (American Standard Code for Information Interchange) codes. ASCII is a 7-bit code, which is represented here with a pair of hexadecimal digits.

ASCII Hex value	ASCII Hex Value	ASCII Hex Value	ASCII Hex Value
NUL 00	SP 20	@ 40	` 60
SOH 01	! 21	A 41	a 61
STX 02	" 22	B 42	b 62
ETX 03	# 23	C 43	c 63
EOT 04	\$ 24	D 44	d 64
ENQ 05	% 25	E 45	e 65
ACK 06	& 26	F 46	f 66
BEL 07	' 27	G 47	g 67
BS 08	(28	H 48	h 68
HT 09) 29	I 49	i 69
LF 0A	* 2A	J 4A	j 6A
VT 0B	+ 2B	K 4B	k 6B
FF 0C	, 2C	L 4C	l 6C
CR 0D	- 2D	M 4D	m 6D
SO 0E	. 2E	N 4E	n 6E
SI 0F	/ 2F	O 4F	o 6F
DLE 10	0 30	P 50	p 70
DC1 11	1 31	Q 51	q 71
DC2 12	2 32	R 52	r 72
DC3 13	3 33	S 53	s 73
DC4 14	4 34	T 54	t 74
NAK 15	5 35	U 55	u 75
SYN 16	6 36	V 56	v 76
ETB 17	7 37	W 57	w 77
CAN 18	8 38	X 58	x 78
EM 19	9 39	Y 59	y 79
SUB 1A	: 3A	Z 5A	z 7A
ESC 1B	; 3B	[5B	{ 7B
FS 1C	< 3C	\ 5C	7C
GS 1D	= 3D] 5D	} 7D
RS 1E	> 3E	^ 5E	~ 7E
US 1F	? 3F	_ 5F	DEL 7F

