



MagneSafe I-65

Hybrid Insertion Secure Card Reader Authenticator for Magstripe and Smart Card

The MagneSafe I-65 manual insertion style Secure Card Reader Authenticator (SCRA) allows for fast and reliable reading of magstripe and/or Smart Card data on cards that meet the ISO 7810, 7811, 7816 specifications. Its ergonomically designed chassis allows for easy user interface, and ensures accurate and consistent card reading under all conditions.

Benefits

The MagneSafe I-65 can withstand a wide range of operational and environmental conditions, and is an ideal solution for environments such as ATM, Vending Machine, or Self-Service kiosks.

The optional card-latch feature allows the card to be securely held within the reader during the entire transaction process, and reduces the possibility of unwanted human intervention during card read operations. Power-fail card latch release and manual override features are available to ensure that a customer's card can be easily retrieved under any condition.

The Reader communicates to a host using an RS-232 or USB interface with a defined protocol and command set. The 3-track Reader has an industry standard mechanical footprint. The MagneSafe I-65 is designed for self-service applications such as ATMs, vending machines, kiosks, and fuel pumps.

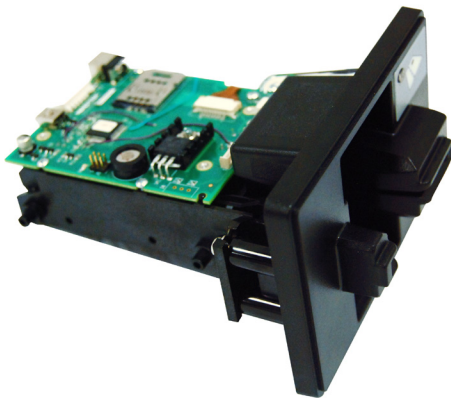

MagneSafe I-65

Insertion secure card reader authenticator able to read magstripes and smart cards



Call a representative to learn more: 562-546-6400.

Specifications

Features

- Reads magnetic stripe cards
- Reads encoded data that meets ANSI/ISO/AAMVA standards
- Reads up to three tracks of card data
- Supplies 54 byte MagnePrint™ value
- Encrypts all track data and the MagnePrint value
- Provides clear text confirmation data including cardholder's name, expiration date, and a portion of the PAN as part of the Masked Track Data
- Communicates with ISO smart cards and many popular memory cards
- Supports one on-board SAM (Security Access Module)
- Includes an integrated USB interface
- Optionally supports Contactless smart card communication

Configuration

Most of the MagneSafe I-65 readers include the following capabilities:

- MagneSafe features including key management, encryption and MagnePrint
- USB and RS-232 interface
- Smart Card connector with 8 contacts
- Single SAM socket
- Debris gate
- Card retention latch with power fail release
- Single 3-track head with integrated encryption and MagnePrint
- Card seated switch integrated into the contact block
- Bezel with built-in red/green LED

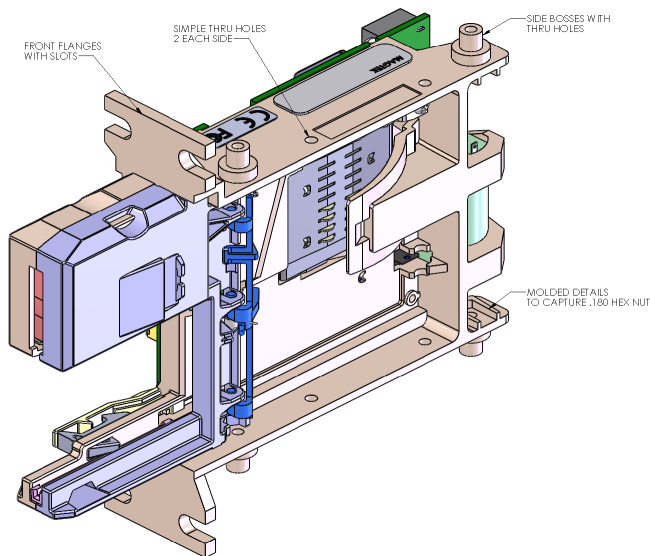

SPECIFICATIONS	
Reference Standards	ISO/AAMVA/JIS formats ISO 7810, 7811, JIS x 6302 Type 2 ISO 7816 T=0 and T=1 protocols, many popular memory cards EMVCo Level 1 Approval
Magstripe Functions	Track 1,2,3
Smart card Functions	Data Format Specification*
Recording Method	Two-frequency coherent phase (F2F)
Card Speed	3 IPS (7,62 cm/sec) to 50 IPS (127, cm/sec)
* ISO (International Standards Organization), AAMVA, (American Association of Motor Vehicle Administrators), JIS (Japanese Industrial Standard)	
OPERATING	
Chassis Mounting Options	Front Flange, Side Mounting Studs, Side Mounting Holes
MTBF	
Head	1,000,000 passes (1,000,000 Insertion Cycles)
Smart card contacts	500,000 insertions
ELECTRICAL	
Input Voltage	12.0 VDC +/- 5%
Current	
With latch	500mA max
Without latch	400mA max
Idle	70mA idle
With contactless, add	500mA
ENVIRONMENTAL	
Temperature	
Operating	-4°F to 122°F (-20° C to 60°C) (without contactless smart card option) -4°F to 122°F (-20°C to 50°C) (with contactless smart card option)
Storage	-4°F to 158°F (-20°C to 70°C)
Humidity	
Operating	10% to 90% noncondensing
Storage	10% to 90% noncondensing
Altitude	
Operating	0 - 10,000 ft. (0 - 3,048m)
Storage	0 - 50,000 ft. (0 - 15,240m)
DIMENSIONS	
Overall Length	4.70 in. (119.4mm)
Mounting Depth	3.80 in. (96.5mm) with front flanges
Height	1.40 in. (35.6mm)
Width	2.60 in. (66.0mm) w/o mounting bosses or flanges
Weight	5.02 oz (142.2g)