

# **FULL SIZE PORT POWERED SWIPE READER TECHNICAL REFERENCE MANUAL**

**Manual Part Number 99875180 Rev 6**

**JUNE 2010**

**MAGTEK<sup>®</sup>**  
**REGISTERED TO ISO 9001:2008**  
1710 Apollo Court  
Seal Beach, CA 90740  
Phone: (562) 546-6400  
FAX: (562) 546-6301  
Technical Support: (651) 415-6800  
*www.magtek.com*

Copyright© 2000-2010  
MagTek®, Inc.  
Printed in the United States of America

Information in this document is subject to change without notice. No part of this document may be reproduced or transmitted in any form or by any means, electronic or mechanical, for any purpose, without the express written permission of MagTek, Inc.

MagTek is a registered trademark of MagTek, Inc.  
Procomm is a registered trademark of Datastorm Technologies, Inc.

## REVISIONS

Rev Number	Date	Notes
1	8 Dec 00	Initial Release
2	12 Feb 01	Changed title from "Maxi Port Powered" to "Full-Size Port Powered" throughout manual
3	25 Jul 01	Front Matter: Added to Agency page: FCC Class B, UL and CUL. Copyright 2001 added.
4	07 Aug 02	Sec 1: changed firmware P/N, added related documents, configuration added P/N 21088063, changed firmware P/Ns, added cable lengths, specs added cm card speed, added cable lengths; Sec 3: added note to Table 3-1 for abbreviations.
5	27 May 03	Editorial throughout. Front Matter: added ISO line to logo, changed Tech Support phone number, added new warranty statement. Sec 1 and 3: deleted references to red LED.
6	2 June 10	Formatting changes and updated Limited Warranty & Agency Approvals

## LIMITED WARRANTY

MagTek warrants that the products sold pursuant to this Agreement will perform in accordance with MagTek's published specifications. This warranty shall be provided only for a period of one year from the date of the shipment of the product from MagTek (the "Warranty Period"). This warranty shall apply only to the "Buyer" (the original purchaser, unless that entity resells the product as authorized by MagTek, in which event this warranty shall apply only to the first repurchaser).

During the Warranty Period, should this product fail to conform to MagTek's specifications, MagTek will, at its option, repair or replace this product at no additional charge except as set forth below. Repair parts and replacement products will be furnished on an exchange basis and will be either reconditioned or new. All replaced parts and products become the property of MagTek. This limited warranty does not include service to repair damage to the product resulting from accident, disaster, unreasonable use, misuse, abuse, negligence, or modification of the product not authorized by MagTek. MagTek reserves the right to examine the alleged defective goods to determine whether the warranty is applicable.

Without limiting the generality of the foregoing, MagTek specifically disclaims any liability or warranty for goods resold in other than MagTek's original packages, and for goods modified, altered, or treated without authorization by MagTek.

Service may be obtained by delivering the product during the warranty period to MagTek (1710 Apollo Court, Seal Beach, CA 90740). If this product is delivered by mail or by an equivalent shipping carrier, the customer agrees to insure the product or assume the risk of loss or damage in transit, to prepay shipping charges to the warranty service location, and to use the original shipping container or equivalent. MagTek will return the product, prepaid, via a three (3) day shipping service. A Return Material Authorization ("RMA") number must accompany all returns. Buyers may obtain an RMA number by contacting Technical Support at (888) 624-8350.

**EACH BUYER UNDERSTANDS THAT THIS MAGTEK PRODUCT IS OFFERED AS IS. MAGTEK MAKES NO OTHER WARRANTY, EXPRESS OR IMPLIED, AND MAGTEK DISCLAIMS ANY WARRANTY OF ANY OTHER KIND, INCLUDING ANY WARRANTY OF MERCHANTABILITY OR FITNESS FOR A PARTICULAR PURPOSE.**

IF THIS PRODUCT DOES NOT CONFORM TO MAGTEK'S SPECIFICATIONS, THE SOLE REMEDY SHALL BE REPAIR OR REPLACEMENT AS PROVIDED ABOVE. MAGTEK'S LIABILITY, IF ANY, SHALL IN NO EVENT EXCEED THE TOTAL AMOUNT PAID TO MAGTEK UNDER THIS AGREEMENT. IN NO EVENT WILL MAGTEK BE LIABLE TO THE BUYER FOR ANY DAMAGES, INCLUDING ANY LOST PROFITS, LOST SAVINGS, OR OTHER INCIDENTAL OR CONSEQUENTIAL DAMAGES ARISING OUT OF THE USE OF, OR INABILITY TO USE, SUCH PRODUCT, EVEN IF MAGTEK HAS BEEN ADVISED OF THE POSSIBILITY OF SUCH DAMAGES, OR FOR ANY CLAIM BY ANY OTHER PARTY.

### LIMITATION ON LIABILITY

EXCEPT AS PROVIDED IN THE SECTIONS RELATING TO MAGTEK'S LIMITED WARRANTY, MAGTEK'S LIABILITY UNDER THIS AGREEMENT IS LIMITED TO THE CONTRACT PRICE OF THIS PRODUCT.

MAGTEK MAKES NO OTHER WARRANTIES WITH RESPECT TO THE PRODUCT, EXPRESSED OR IMPLIED, EXCEPT AS MAY BE STATED IN THIS AGREEMENT, AND MAGTEK DISCLAIMS ANY IMPLIED WARRANTY, INCLUDING WITHOUT LIMITATION ANY IMPLIED WARRANTY OF MERCHANTABILITY OR FITNESS FOR A PARTICULAR PURPOSE.

MAGTEK SHALL NOT BE LIABLE FOR CONTINGENT, INCIDENTAL, OR CONSEQUENTIAL DAMAGES TO PERSONS OR PROPERTY. MAGTEK FURTHER LIMITS ITS LIABILITY OF ANY KIND WITH RESPECT TO THE PRODUCT, INCLUDING ANY NEGLIGENCE ON ITS PART, TO THE CONTRACT PRICE FOR THE GOODS.

MAGTEK'S SOLE LIABILITY AND BUYER'S EXCLUSIVE REMEDIES ARE STATED IN THIS SECTION AND IN THE SECTION RELATING TO MAGTEK'S LIMITED WARRANTY

### **FCC WARNING STATEMENT**

This equipment has been tested and was found to comply with the limits for a Class B digital device pursuant to Part 15 of FCC Rules. These limits are designed to provide reasonable protection against harmful interference when the equipment is operated in a residential environment. This equipment generates, uses, and can radiate radio frequency energy and, if not installed and used in accordance with the instruction manual, may cause harmful interference with radio communications. However, there is no guarantee that interference will not occur in a particular installation.

### **FCC COMPLIANCE STATEMENT**

This device complies with Part 15 of the FCC Rules. Operation of this device is subject to the following two conditions: (1) this device may not cause harmful interference, and (2) this device must accept any interference received, including interference that may cause undesired operation.

### **CANADIAN DOC STATEMENT**

This digital apparatus does not exceed the Class B limits for radio noise from digital apparatus set out in the Radio Interference Regulations of the Canadian Department of Communications.

Le présent appareil numérique n'émet pas de bruits radioélectriques dépassant les limites applicables aux appareils numériques de la classe B prescrites dans le Règlement sur le brouillage radioélectrique édicté par le ministère des Communications du Canada.

This Class B digital apparatus complies with Canadian ICES-003.

Cet appareil numérique de la classe B est conforme à la norme NMB-003 du Canada.

### **CE STANDARDS**

Testing for compliance with CE requirements was performed by an independent laboratory. The unit under test was found compliant with standards established for Class B devices.

### **UL/CSA**

This product is recognized per Underwriter Laboratories and Canadian Underwriter Laboratories 1950.

### **RoHS STATEMENT**

When ordered as RoHS compliant, this product meets the Electrical and Electronic Equipment (EEE) Reduction of Hazardous Substances (RoHS) European Directive 2002/95/EC. The marking is clearly recognizable, either as written words like "Pb-free", "lead-free", or as another clear symbol ()

## TABLE OF CONTENTS

<b>SECTION 1. FEATURES AND SPECIFICATIONS</b> -----	<b>1</b>
FEATURES-----	1
RELATED DOCUMENTS-----	2
CONFIGURATION-----	2
SPECIFICATIONS-----	4
<b>SECTION 2. INSTALLATION</b> -----	<b>7</b>
REQUIREMENTS-----	7
INSTALLATION-----	7
TEST-----	7
<b>SECTION 3. OPERATION</b> -----	<b>9</b>
LED INDICATOR-----	9
CARD READ-----	9
READER TO HOST MESSAGE FORMAT-----	9
TIMING FOR ID SIGN ON-----	10

## FIGURES

Figure 1-1. Full-Size Port-Powered Swipe Reader-----	vi
Figure 1-2. Reader Cable and Optional Adapter-----	3
Figure 1-3. Dimensions-----	5
Figure 3-1. Timing For ID Sign-on and Transmission Bursts.-----	10

## TABLES

Table 1-1. 9-Pin Connectors and 25-Pin Adapter-----	3
Table 1-2. Specifications-----	4
Table 3-1. SS and ES Track Symbols-----	9

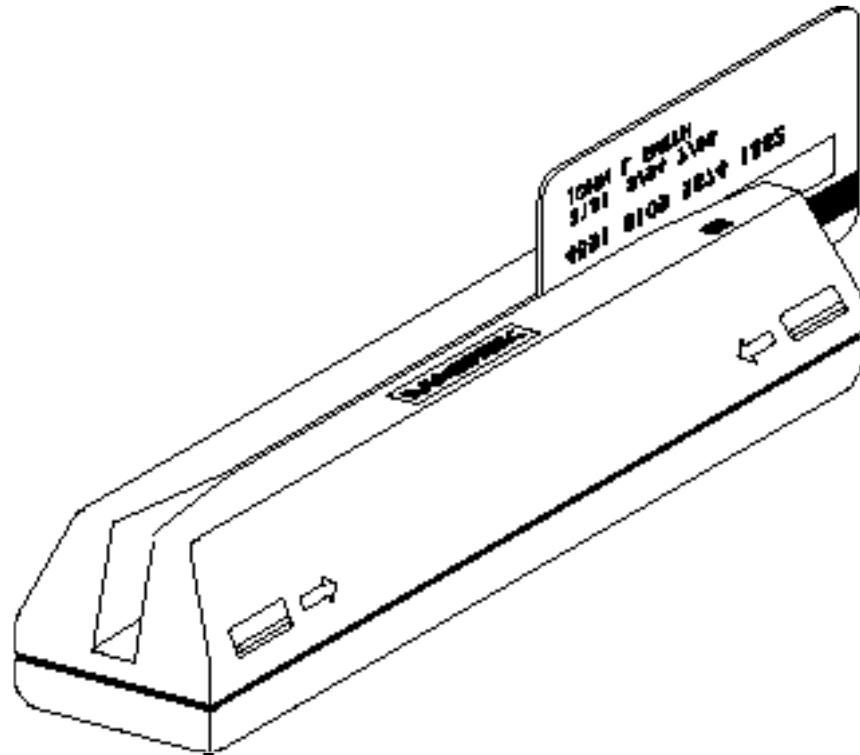

**Figure 1-1. Full-Size Port-Powered Swipe Reader**

## SECTION 1. FEATURES AND SPECIFICATIONS

The Full-Size Port-Powered Swipe Reader is a compact magnetic stripe card reader which conforms to ISO/ANSI standards. The Reader is compatible with the PC series of personal computers or any device with a serial RS-232 interface. A card is read by sliding it, stripe down and facing the LED side, through the slot either forward or backward.

A green LED (Light Emitting Diode) indicator on the Reader panel provides the operator with status of the Reader operations.

When power is applied, the Reader transmits a sign-on ID message. About 150 milliseconds after DTR is applied, the Reader sends the part number of the firmware in the following form: 21088817A01 <CR>. The first 8 characters indicate the firmware number; the letter is the revision, which is followed by a revision sublevel of 01 to 99. The <CR> indicates carriage return (0x0D). The sign-on messages for part numbers are listed in Section 3. Timing is also shown in Section 3.

Since the input voltage is supplied by a relatively low source of power, the Reader depends on its input capacitor to maintain proper charge during all operations. In order to reduce the drain on this internal power source during data transmission, the output data is transmitted in 5 to 6 millisecond bursts with a 10-millisecond gap between bursts to allow the capacitor to recharge. The PC software should be able to tolerate this 10-millisecond space between characters. The Timing is shown in Section 3, Figure 3-1. Configurations, including part numbers, firmware, tracks, and unit configuration, are listed below.

### FEATURES

Major features of the Swipe Reader are as follows:

- Powered through the RS-232 serial port – no external power supply required
- Hardware Compatible with PC or any computer or terminal with an RS-232 interface
- Software Compatible with Procomm, or any RS-232 communications program
- Bidirectional card reading
- Reads encoded data that meets ANSI/ISO/CDL/AAMVA standards
- Green LED for status

## RELATED DOCUMENTS

The MagTek Device Drivers for Windows, Part Number 30037385, may be used with the Full-size Port Powered Swipe Reader. When this program is used, refer to *MagTek Device Driver for Windows, Programming Reference Manual*, Part Number 99875125.

ISO documents available:

ISO 7811

ISO 7812

Phone: 212-642-4900 or [www.ansi.org](http://www.ansi.org)

## CONFIGURATION

The available part number, firmware part number, and configurations are as follows:

Part Number	Firmware	Track Configuration	Configuration	Cable Length
21088061	21088817	1,2, and 3	Pearl White	6'
21088063	21088817	1,2, and 3	Pearl White	10'

The Reader, LED Indicator, pin numbers for the 9-pin connector, and the Adapter are shown in Figure 1-2.

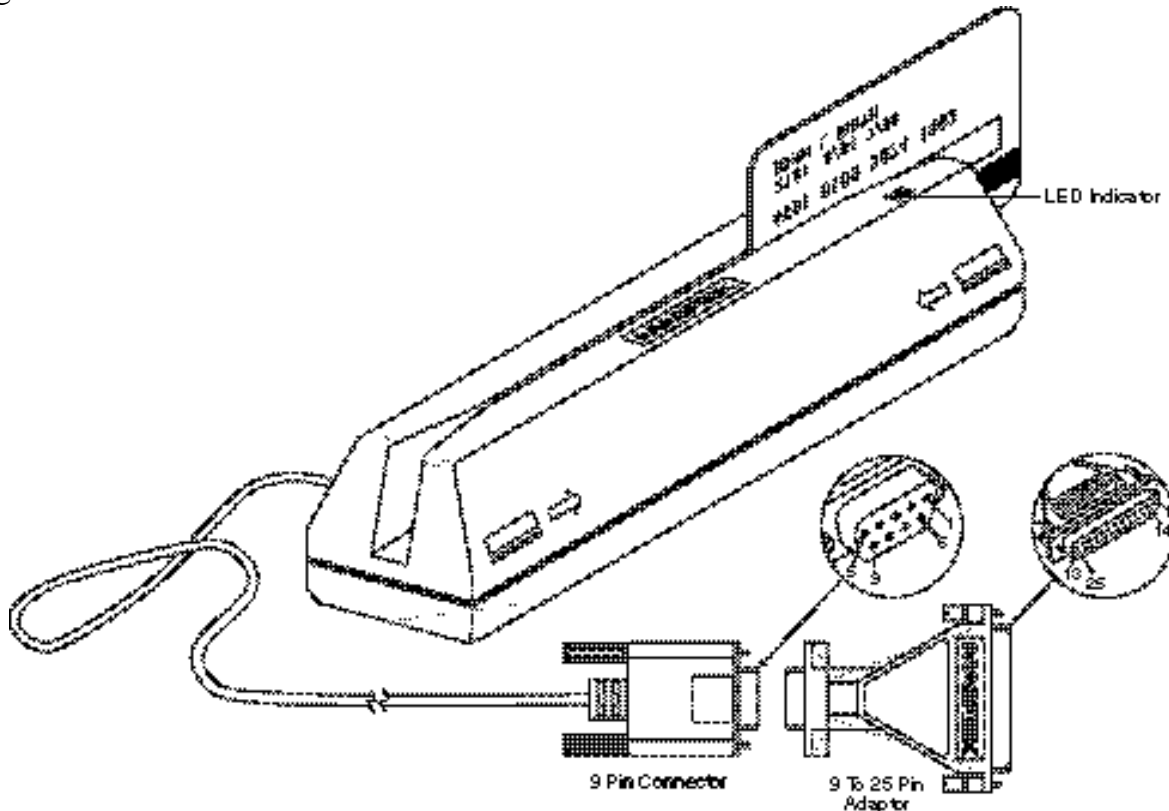

**Figure 1-2. Reader Cable and Optional Adapter**

Pin numbers and signal descriptions for the 9-pin (DE9) cable and 25-pin (DB25) adapter shown in the illustration are listed in Table 1-1.

**Table 1-1. 9-Pin Connectors and 25-Pin Adapter**

25-pin Adapter	DE9-pin Connector	Signal
-	1	NC*
3	2	RXD (to PC)
2	3	TXD** (from PC)
20	4	DTR (from PC)
7	5	GND
-	6-9	NC*

\* No Connection

\*\* Pin must be connected to TXD (or DTR if TXD not available).

## SPECIFICATIONS

Table 1-2 lists the specifications for the Full-size Port Powered Swipe Reader. Figure 1-3 shows the dimensions for the standard product.

**Table 1-2. Specifications**

<b>OPERATING</b>	
Reference Standards	ISO/ANSI/ CDL/ AAMVA*
Power Input	From RS-232 interface
Recording Method	Two-frequency coherent phase (F2F)
Message Format	ASCII
Card Speed	3 to 50 IPS (7.6 to 127 cm/sec) – forward or reverse
MTBF	Electronics: 125,000 hours. Head: 1,000,000 passes
<b>ELECTRICAL</b>	
DTR Voltage	5 to 15 VDC
Current	
Quiescent	1 to 2 mA typical (continuous)
Transmitting	8 to 9 mA typical (5 ms duration)
Peak at Power On	12 mA
RS-232 Communication	9600 bps, no parity, 8 data bits, 1 stop bit
<b>MECHANICAL (STANDARD PRODUCT)</b>	
Dimensions	Length: 6.5" (165.1 mm), Width: 1.75" (44.45 mm) Height: 1.625" (41.28 mm)
Weight	Reader with cable 6.74 oz (191.16 g) 9 – 25pin Adapter 1.72 oz (48.71 g)
Cable length	6 Ft. (1.8 M) or 10 Ft. (3 M)
Connector	9 pin D female (May require a 25-pin adapter)
<b>ENVIRONMENTAL</b>	
Temperature	
Operating	32°F to 131°F (0°C to 55°C)
Storage	-22°F to 158°F (-30°C to 70°C)
Humidity	
Operating	10% to 90% noncondensing
Storage	Up to 100% noncondensing
Altitude	
Operating	0-10,000 ft. (0-3048 m.)
Storage	0-50,000 ft. (0-15240 m.)

\* ISO (International Standards Organization), ANSI (American National Standards Institute), CDL (California Drivers License), and AAMVA (American Association of Motor Vehicle Administrators).

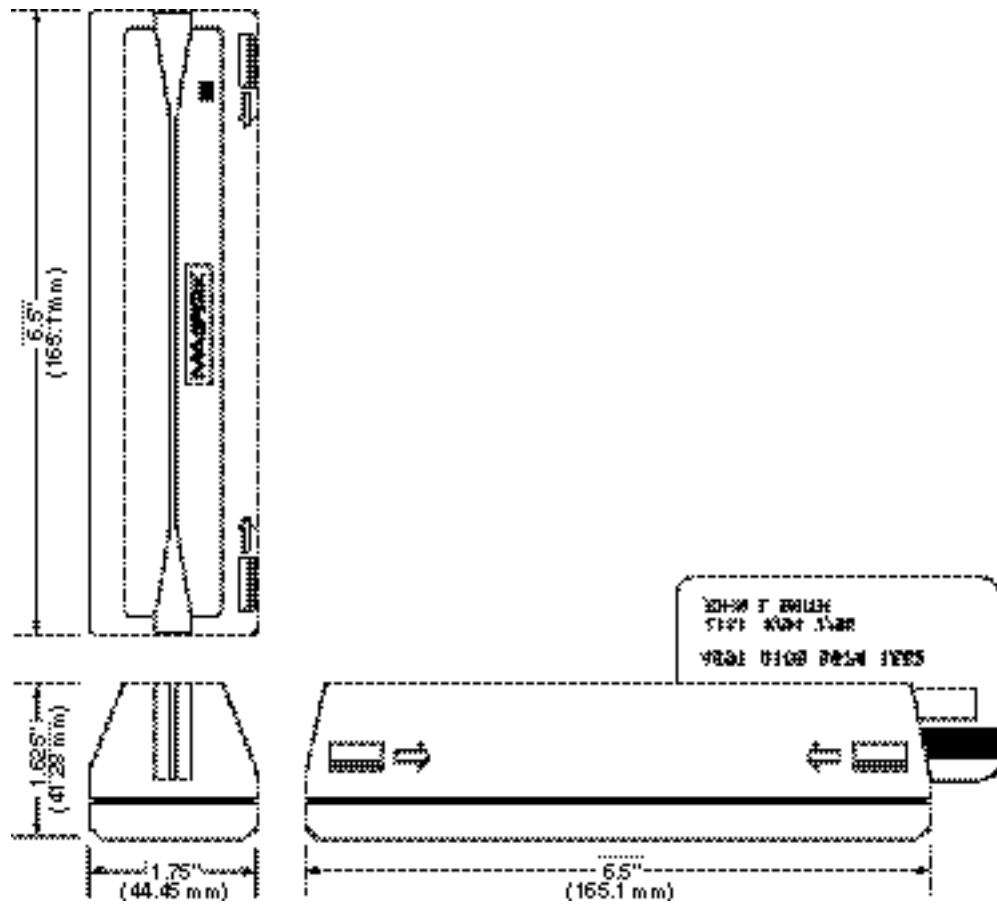

Figure 1-3. Dimensions



## SECTION 2. INSTALLATION

The hardware installation consists of plugging the cable into the PC, Com Port setup, and testing the Reader.

### REQUIREMENTS

- Full-size Port Powered Swipe Reader
- Optional 9- to 25-pin Adapter, P/N 78200018
- PC with Com Port

### INSTALLATION

1. Connect the Swipe Reader cable connector into a 9-pin serial Com Port on the PC. If a 25-pin Adapter is required, plug the 9-pin connector on the Reader into the Adapter, and the Adapter into the PC.
2. Ensure the Reader is positioned on a flat, accessible surface with at least 4 inches clearance on either end for room to swipe a card. Orient the Reader so the side with the LED is facing the direction of intended use.
3. If fastening tape is to be used, clean the area that the Reader will be mounted on with isopropyl alcohol. Wait for the alcohol to evaporate. Remove the adhesive protective cover on the fastening tape, and position the Reader and push down firmly.

### TEST

To test the Swipe Reader, perform the following steps:

1. Open a communications program such as the MagTek Encoder/Reader Demonstration Program, which may be obtained from the Internet at [www.magtek.com](http://www.magtek.com). Navigate to the Demo Programs and select Reader & Encoder Demos (Win 95/98/NT/2000/XP).
2. On the program, select the Com Port the Reader is connected to.
3. If the Com Port selected is correct, the green LED on the Reader will light; if the *wrong* Com Port is selected, the LED will not illuminate.
4. Select the baud rate of 9600.
5. Select 8 data bits, no parity, 1 stop bit.

## Full-Size Port-Powered Swipe Reader

---

6. With the LED on, swipe a card. The data on the screen will show Track 1 beginning with “%” and ending with “?”. Track 2 begins with “;” and ends with “?”. Track 3 begins with “+” (normal) or “!” (CDL) and ends with “?”. The following is an example:

```
%B123^Smith/Joann^9812101000?;1122223333334444444444?<0x0D>
```

If a track cannot be read, an **E** will appear in place of the track data; for example, if Track 2 is bad and Tracks 1 and 3 are good, the display will be similar to the following:

```
%11111111111111111111?;E?+33333333333333333333?<0x0D>
```

If Tracks 1 and 3 are bad and Track 2 is good, the display will be similar to the following:

```
%E?;22222222222222222222?+E?<0x0D>
```

7. If the data on the screen is not numeric or alphanumeric similar to the above, check the communications rate. If the alphanumeric characters are similar to the above, the unit is ready for operation.

## SECTION 3. OPERATION

Included in this section are Indicator, Card Read, Reader to Host Message Format, and a timing diagram of data transmission.

### LED INDICATOR

A green LED indicator on the panel gives the operator the status of the Reader. If the cabling is correct and the correct Com Port is selected, the green indicator will be on. The LED is turned off during a card swipe and while the unit is transmitting.

### CARD READ

A card may be swiped through the Reader slot when the green LED is lit. The magnetic stripe must face toward the front (the side with the LED) and may be swiped in either direction.

### READER TO HOST MESSAGE FORMAT

Track data is sent in the following order: SS, Card Data, ES.

The format in which data is transmitted (in track order) after a card is read successfully is as follows:

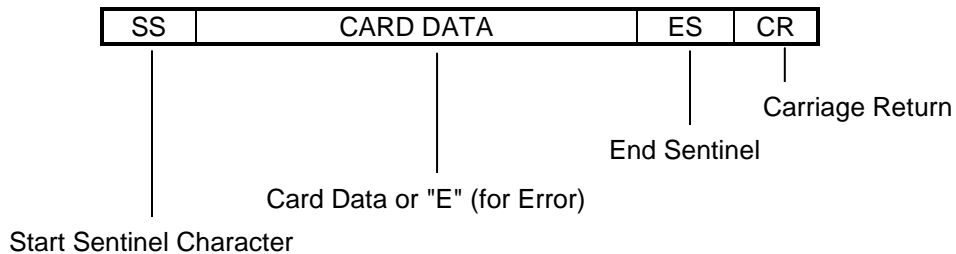

Table 3-1 lists Start Sentinel and End Sentinel symbols.

**Table 3-1. SS and ES Track Symbols**

Start Sentinel	End Sentinel	Description
%	?	Track 1
;	?	Track 2
+	?	Track 3 – ISO*
#	?	Track 3 – AAMVA*
!	?	Track 3 – CDL*

\*See Table 1-2 for definitions of abbreviations.

### TIMING FOR ID SIGN ON

Timing for the ID Sign-on and transmission bursts (5 ms with 10 ms between bursts) are shown in Figure 3-1.

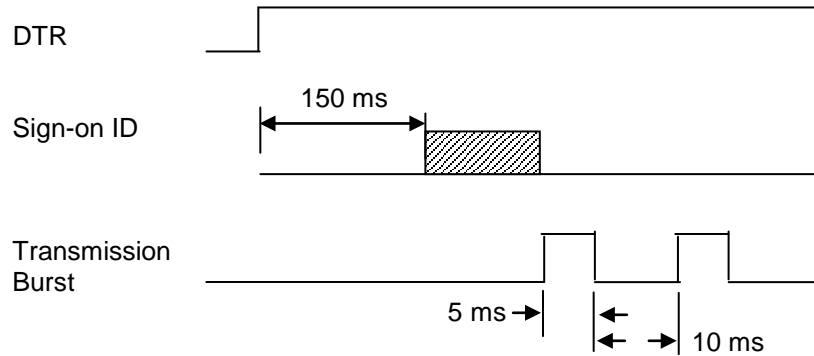

**Figure 3-1. Timing For ID Sign-on and Transmission Bursts.**

The firmware controls the operation of Sign-on ID and Transmission bursts in the following format:

210888xxLnn <CR>

Where:

the first 8 digits are the firmware part number (xx represents the Swipe Reader series),

L is the alpha revision,

nn is the number sub-revision.

<CR> is 0x0D.