

MODEL MT-95
RS-232 HiCo/LoCo ENCODER/READER
INSTALLATION AND OPERATION MANUAL

Manual Part Number 99875075 Rev 11

OCTOBER 2004

MAGTEK[®]

REGISTERED TO ISO 9001:2000

1710 Apollo Court

Seal Beach, CA 90740

Phone: (562) 546-6400

FAX: (562) 546-6301

Technical Support: (651) 415-6800

www.magtek.com

Information in this document is subject to change without notice. No part of this document may be reproduced or transmitted in any form or by any means, electronic or mechanical, for any purpose, without the express written permission of MagTek, Inc.

MagTek is a registered trademark of MagTek, Inc.

REVISIONS

Rev Number	Date	Notes
1	6 Jun 97	Initial Release
2	8 Jan 98	Name change from MT-310232 to MT-95; Updated to new firmware Revision; Changed Main Menu and subordinate menus; Changed titles and content of Sections 3 and 4 and added 5; added Appendix A.
3	23 Sep 99	Sec 1: Added 4777 emulation mode to features and requirements, LCD to Spec, Sec 5: Added new response to "Change Configuration; Added Sec 6 4777 emulation mode; Appendix A: Added Connector illustration, editorial .
4	24 Jul 00	Section 1 and 2, added IntelliCoder, features, and related hardware and instructions; Section 5, removed one PC encoded example.
5	05 Jun 01	Editorial throughout. Updated dialog boxes to latest engineering revision J07.
6	31 Jul 01	Front Matter, Agency Approvals: Added CE, Class A approval.
7	20 Nov 02	Editorial throughout. Section 5: Added new commands and modifications from New Zealand, K04.
8	13 Mar 03	Replaced some fonts so manual would print on all printers.
9	18 Apr 03	Front Matter: added ISO line to logo, changed Tech Support phone number, added new warranty statement.
10	6 Nov 03	Editorial throughout. Added many index items.
11	14 Oct 04	Sec 5, Encoded Message Format: Changed table to include "3-track with %" sign; Online Encode Formats: deleted "# data ?" line; Encode Cmd with Status Response: in table [TRK 3] deleted "(or #, 0x23)".

LIMITED WARRANTY

MagTek warrants that the products sold to Reseller pursuant to this Agreement will perform in accordance with MagTek's published specifications. This warranty shall be provided only for a period of one year from the date of the shipment of the product from MagTek (the "Warranty Period"). This warranty shall apply only to the original purchaser unless the buyer is authorized by MagTek to resell the products, in which event, this warranty shall apply only to the first repurchase.

During the Warranty Period, should this product fail to conform to MagTek's specifications, MagTek will, at its option, repair or replace this product at no additional charge except as set forth below. Repair parts and replacement products will be furnished on an exchange basis and will be either reconditioned or new. All replaced parts and products become the property of MagTek. This limited warranty does not include service to repair damage to the product resulting from accident, disaster, unreasonable use, misuse, abuse, customer's negligence, Reseller's negligence, or non-MagTek modification of the product. MagTek reserves the right to examine the alleged defective goods to determine whether the warranty is applicable.

Without limiting the generality of the foregoing, MagTek specifically disclaims any liability or warranty for goods resold in other than MagTek's original packages, and for goods modified, altered, or treated by customers.

Service may be obtained by delivering the product during the warranty period to MagTek (1710 Apollo Court, Seal Beach, CA 90740). If this product is delivered by mail or by an equivalent shipping carrier, the customer agrees to insure the product or assume the risk of loss or damage in transit, to prepay shipping charges to the warranty service location and to use the original shipping container or equivalent. MagTek will return the product, prepaid, via a three (3) day shipping service. A Return Material Authorization (RMA) number must accompany all returns.

MAGTEK MAKES NO OTHER WARRANTY, EXPRESS OR IMPLIED, AND MAGTEK DISCLAIMS ANY WARRANTY OF ANY OTHER KIND, INCLUDING ANY WARRANTY OF MERCHANTABILITY OR FITNESS FOR A PARTICULAR PURPOSE.

EACH PURCHASER UNDERSTANDS THAT THE MAGTEK PRODUCT IS OFFERED AS IS. IF THIS PRODUCT DOES NOT CONFORM TO MAGTEK'S SPECIFICATIONS, THE SOLE REMEDY SHALL BE REPAIR OR REPLACEMENT AS PROVIDED ABOVE. MAGTEK'S LIABILITY, IF ANY, TO RESELLER OR TO RESELLER'S CUSTOMERS, SHALL IN NO EVENT EXCEED THE TOTAL AMOUNT PAID TO MAGTEK BY RESELLER UNDER THIS AGREEMENT. IN NO EVENT WILL MAGTEK BE LIABLE TO THE RESELLER OR THE RESELLER'S CUSTOMER FOR ANY DAMAGES, INCLUDING ANY LOST PROFITS, LOST SAVINGS OR OTHER INCIDENTAL OR CONSEQUENTIAL DAMAGES ARISING OUT OF THE USE OF OR INABILITY TO USE SUCH PRODUCT, EVEN IF MAGTEK HAS BEEN ADVISED OF THE POSSIBILITY OF SUCH DAMAGES, OR FOR ANY CLAIM BY ANY OTHER PARTY.

LIMITATION ON LIABILITY

EXCEPT AS PROVIDED IN THE SECTIONS RELATING TO MAGTEK'S LIMITED WARRANTY, MAGTEK'S LIABILITY UNDER THIS AGREEMENT IS LIMITED TO THE CONTRACT PRICE OF THE PRODUCTS.

MAGTEK MAKES NO OTHER WARRANTIES WITH RESPECT TO THE PRODUCTS, EXPRESSED OR IMPLIED, EXCEPT AS MAY BE STATED IN THIS AGREEMENT, AND MAGTEK DISCLAIMS ANY IMPLIED WARRANTY, INCLUDING WITHOUT LIMITATION ANY IMPLIED WARRANTY OF MERCHANTABILITY OR FITNESS FOR A PARTICULAR PURPOSE.

MAGTEK SHALL NOT BE LIABLE FOR CONTINGENT, INCIDENTAL, OR CONSEQUENTIAL DAMAGES TO PERSONS OR PROPERTY. MAGTEK FURTHER LIMITS ITS LIABILITY OF ANY KIND WITH RESPECT TO THE PRODUCTS, INCLUDING ANY NEGLIGENCE ON ITS PART, TO THE CONTRACT PRICE FOR THE GOODS.

MAGTEK'S SOLE LIABILITY AND BUYER'S EXCLUSIVE REMEDIES ARE STATED IN THIS SECTION AND IN THE SECTION RELATING TO MAGTEK'S LIMITED WARRANTY.

FCC WARNING STATEMENT

This equipment has been tested and found to comply with the limits for a Class A digital device, pursuant to Part 15 of FCC Rules. These limits are designed to provide reasonable protection against harmful interference when the equipment is operated in a commercial environment. This equipment generates, uses, and can radiate radio frequency energy and, if not installed and used in accordance with the instruction manual, may cause harmful interference to radio communications. Operation of this equipment in a residential area is likely to cause harmful interference in which case the user will be required to correct the interference at his own expense.

FCC COMPLIANCE STATEMENT

This device complies with Part 15 of the FCC Rules. Operation of this device is subject to the following two conditions: (1) This device may not cause harmful interference. And (2) This device must accept any interference received, including interference that may cause undesired operation.

CANADIAN DOC STATEMENT

This digital apparatus does not exceed the Class A limits for radio noise for digital apparatus set out in the Radio Interference Regulations of the Canadian Department of Communications.

Le présent appareil numérique n'émet pas de bruits radioélectriques dépassant les limites applicables aux appareils numériques de la classe A prescrites dans le Règlement sur le brouillage radioélectrique édicté par le ministère des Communications du Canada.

CE STANDARDS

Testing for compliance to CE and FCC requirements was performed by an independent laboratory. The unit under test was found compliant to Class A.

UL/CSA

This product is recognized per Underwriter Laboratories and Canadian Underwriter Laboratories 1950.

TABLE OF CONTENTS

SECTION 1. FEATURES AND SPECIFICATIONS.....	1
FEATURES.....	1
Standard Mode	1
IntelliCoder.....	1
4777 Emulation Mode.....	1
REQUIREMENTS	2
Standard Mode	2
IntelliCoder.....	2
4777 Emulation Mode.....	2
SPECIFICATIONS	3
SECTION 2. INSTALLATION AND SETUP	5
PARTS REQUIRED	5
Standard MT-95.....	5
IntelliCoder.....	5
4777 Emulation MT-95	5
HARDWARE INSTALLATION	5
SETUP - STANDARD MODE	8
Normal Mode	11
Secure Mode	11
Setup - IntelliCoder.....	13
SECTION 3. STANDALONE OPERATION.....	15
CARD READING AND ENCODING FUNDAMENTALS.....	15
CARD READING	18
CARD COPYING	19
CARD ENCODING	20
Free Format Encoding.....	20
Fixed Format Encoding	22
Create Format Card.....	24
SECTION 4. ONLINE CARD OPERATION.....	27
CARD READING	27
CARD ENCODING	27
SECTION 5. ONLINE PROGRAMMING	29
ENCODED MESSAGE FORMAT	29
ENCODE COMMAND IN SECURE MODE	30
PC ENCODED EXAMPLE	30
ONLINE COMMANDS	31
Change Encode Coercivity Mode.....	31
Change Online Encode Mode	31
Change Display	31
Change Configuration.....	32
Abort	32
Operation	32
ONLINE ENCODE FORMATS (NON-SOFTWARE MODE)	33
ONLINE MODES	34
Normal Mode	34
Software Controlled Mode	34
Secure Mode	35
TRACK CHARACTER SETS	35
IDLE MESSAGE	37
Top and Bottom Line	37
Bottom Line.....	38
DISPLAY IMMEDIATE.....	39
ENCODE COMMAND WITH STATUS RESPONSE.....	40
SOFTWARE CONTROLLED ENCODE RETURNED STATUS.....	42
SOFTWARE CONTROLLED READ COMMAND.....	43
SET / RETRIEVE DSN	44
SOFTWARE ENCODE MESSAGE	45

SECTION 6. 4777 EMULATION MODE	47
INSTALLATION OF 4777 EMULATION MODE	47
MT-95 SETUP FOR ENCODE ENERGY	47
MODIFYING IDLE MESSAGE ON MT-95.....	48
MODIFYING ENCODE TIMEOUT	49
MT-95 USER MESSAGES	50
APPENDIX A. PIN LISTS	53
APPENDIX B. TESTS	55
SOFTWARE MODE	55
SET IDLE MESSAGES.....	55
SOFTWARE CONTROLLED READ	55
SOFTWARE CONTROLLED ENCODE	56
INDEX	57

FIGURES

Figure 1-1. MT-95 Encoder/Reader	viii
Figure 1-2. Encoder Parts and Card Orientation	4
Figure 2-1. Rear Panel.....	6
Figure 2-2. Encoder to Keyboard Connection.....	7
Figure 2-3. Encoder to PC Connection	7
Figure A-1. DE-9 Connector.....	53

TABLES

Table 1-1. Specifications	3
Table 2-1. Default Parameters	10
Table 4-1. Track 1/3 7-Bit Character Set	36
Table 4-2. Track 2/3 5-Bit Character Set	36
Table A-1. Cable DE-9P to DE-9S (21015823)	53
Table A-2. Cable DE-9P to DB-25S (21015821)	53

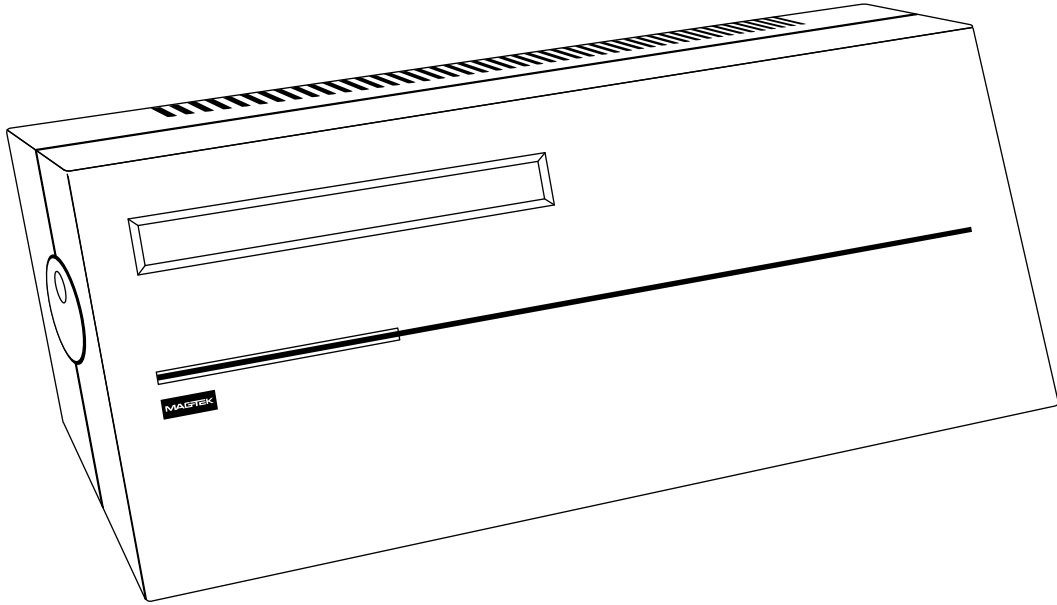

Figure 1-1. MT-95 Encoder/Reader

SECTION 1. FEATURES AND SPECIFICATIONS

The Model MT-95 RS-232 HiCo/LoCo Encoder/Reader encodes (or writes) and reads on 3-track magnetic stripes which comply with ISO standards 7810, 7811-2, -4, -5, -6, and 7813. The Encoder can read or write on all three tracks of the magnetic stripe on LoCo (low coercivity or low energy) or HiCo (high coercivity or high energy) cards. HiCo cards are more difficult to erase, but LoCo cards can be erased by a small magnet.

A liquid crystal display (LCD) prompts the operator for encoding, reading, clearing tracks, communication setup, and some errors (such as, "Could not read track"). A circular knob with a finger hold on the left side of the unit permits an intensity adjustment (which is actually the viewing angle) of the LCD.

FEATURES

The features listed below are for the various versions of the MT-95. The IntelliCoder is a version of the MT-95 that operates with the IntelliCAT Software Suite.

Standard Mode

- Encodes and reads in standalone mode with a keyboard or in online mode with a PC
- Fixed or constant data can be programmed requiring only variable data to be entered by the operator
- Encodes on one, two, or all three tracks
- Supports HiCo or LoCo in one unit
- New or existing cards can be encoded and verified in a matter of seconds
- Easy to operate with operator prompts, preprogrammed repetitive data, display screens that instruct the operator on encoding sequence
- When online, database file management easily built and maintained, which generates audit reports on demand
- Maximum security with passwords, software counters, and encrypted numbers for the counters when using optional PC software

IntelliCoder

- Especially configured to operate with IntelliCAT Software Suite
- Supports HiCo or LoCo in one unit

4777 Emulation Mode

- Encodes on one, two, or all three tracks

MT-95 RS-232 HiCo/LoCo Encoder/Reader

- Supports HiCo or LoCo in one unit
- Easy to operate with operator prompts, preprogrammed repetitive data, display screens that instruct the operator on encoding sequence
- Any existing 4777-3 can be replaced with the MT-95 HiCo Card Encoder
- Existing applications that encode LoCo cards on the 4777 can use the MT-95 in Auto mode to encode HiCo or LoCo cards
- Easy-to-understand prompts at each step of the read and encode operation with operator-friendly 80-character messages with an idle prompt that can be customized
- With MagTek cable (P/N 21015846), operates seamlessly with IBM 4778 PIN-Pad - no retrofits required
- Easy installation - after power is applied, the unit operates without any changes to the PC software - no drivers to install, no configurations to modify, no new software to learn

REQUIREMENTS

The requirements listed below are for the three versions of the MT-95.

Standard Mode

- Model MT-95 RS-232 HiCo/LoCo Encoder/Reader P/N 31010019
- MagTek Keyboard, P/N 93600047, or equivalent AT style keyboard (optional)
- PC or Terminal with software to operate the serial port for sending and receiving data (MagTek offers the MT-80 software program P/N 15030402, manual P/N 99815005.)
- PC Cable for DE9P Male Connector P/N 21015823; or PC Cable for DB25P Male Connector P/N 21015821 (must be ordered separately)
- Power Cord P/N 71100001 (included)

IntelliCoder

- Model IntelliCoder, RS-232, HiCo Encoder/Reader, P/N 31010021
- Cable, P/N 21015847 (9-pin to 9-pin) (included)
- Power Cord, P/N 71100001 (included)

4777 Emulation Mode

- Model MT-95 RS-232 HiCo/LoCo Encoder/Reader P/N 31010020
- Cable P/N 21015846 (MT-95 to IBM 4778 PIN-Pad) (included)
- Power Cord , P/N 71100001 (included)

SPECIFICATIONS

The specifications are listed in Table 1-1 and a diagram of parts and the card orientation are shown in Figure 1-2. The card is oriented with the magnetic stripe down for reading and encoding as shown in the illustration.

Table 1-1. Specifications

Power:	115/230 VAC, 50/60 Hz at 1A
LCD Characters	2 lines X 40 characters
Dimensions	
Height:	5.2 "
Depth:	7.0"
Width:	13.6"
Weight:	6.8 lbs
Magnetic Read Capabilities	3 Tracks
Interface - serial	RS-232 AT-style Keyboard (MagTek P/N 93600047)
Read/Write Head Cycles	1,000,000 passes
Card Standards:	Magnetic Stripe Cards per ISO 7810, 7811, 7813
Card Thickness	0.027 inch to 0.033 inch
Operating Temperature	60° to 90° F (15° to 32° C)
Storage Temperature	32° to 122° F (0° to 50° C)
Operating Humidity	15%-90% (Noncondensing)
Storage Humidity	10%-100%(Noncondensing)

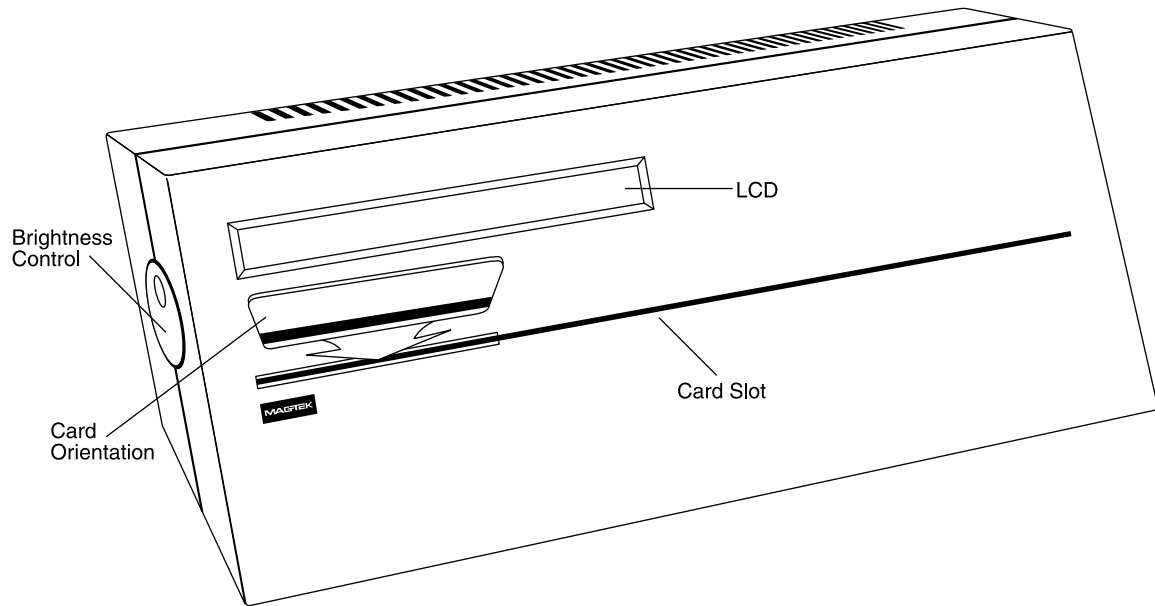

Figure 1-2. Encoder Parts and Card Orientation

SECTION 2. INSTALLATION AND SETUP

Before installing the Encoder, check the packing slip to ensure the order is correct and all parts are included. Check for the following:

PARTS REQUIRED

Standard MT-95

- Model MT-95 RS-232 HiCo Encoder/Reader P/N 31010019
- Power Cord P/N 71100001 (included)
- HiCo and LoCo test cards (1 each)
- Optional MagTek Keyboard, P/N 93600047 (if a PC is to be used, the keyboard is not required)
- Optional PC Cable either for DE9P Male Connector P/N 21015823 or for DB25P Male Connector P/N 21015821 (pin lists are shown in Appendix A)

IntelliCoder

- Model IntelliCoder, RS-232, HiCo/LoCo Encoder Reader, P/N 31010021
- Power Cord, P/N 71100001 (included)
- PC Cable, 9-pin to 9-Pin, P/N21015847 (included)

4777 Emulation MT-95

- Model MT-95 RS-232 HiCo Encoder/Reader P/N 31010020
- Power Cord P/N 71100001 (included)
- HiCo and LoCo test cards (1 each)
- Cable P/N 21015846 (MT-95 to IBM 4778 PIN-Pad) (included)

HARDWARE INSTALLATION

To install the encoder, perform the following steps in the Standard mode as described below:

Note

See Section 6 for installing the 4777 emulation version.

MT-95 RS-232 HiCo/LoCo Encoder/Reader

1. The rear panel of the encoder is shown in Figure 2-1. If a keyboard is to be used, plug the cord from the keyboard to the rear panel of the encoder marked “KEYBOARD” as shown in Figure 2-2, and go to step 2.

or

If a PC is to be used, select either the 9- or 25-pin cable and plug the 9-pin connector on the encoder rear panel marked “MODEM” to the 9- or 25-pin connector on the PC as shown in Figure 2-3.

2. Plug the female end of the power cord into the rear panel of the encoder marked “POWER”. Plug the other end into a power source.
3. Press “I” on the switch marked “ON” .
4. Ensure the proper Communication Port is selected on the PC, if applicable.
5. The default communication parameters on the encoder are shown in Table 2-1. The parameters may be changed as described in Setup. Ensure the parameters on the PC are the same as those on the encoder.

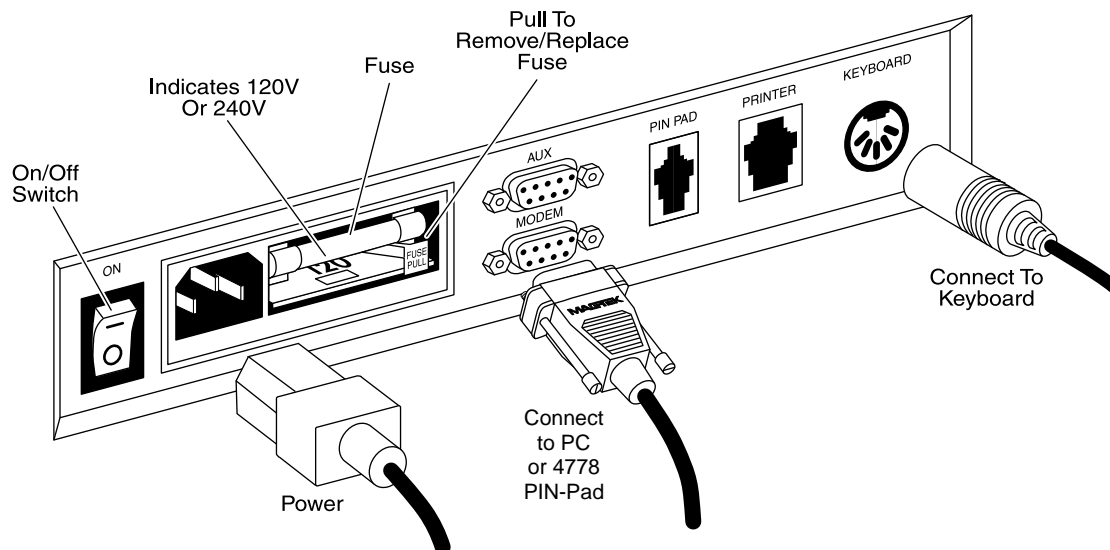

Figure 2-1. Rear Panel

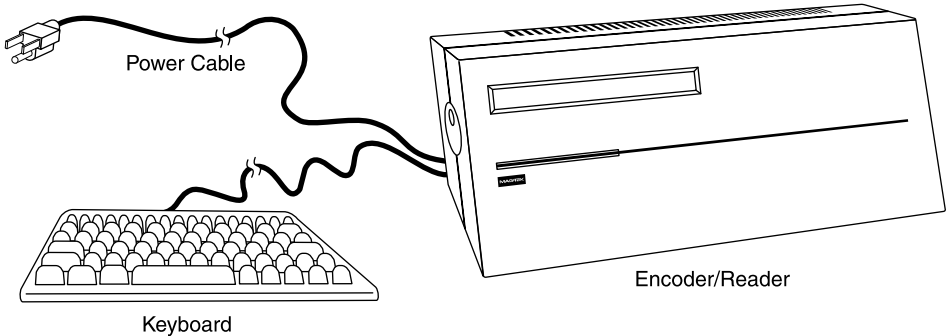

Figure 2-2. Encoder to Keyboard Connection

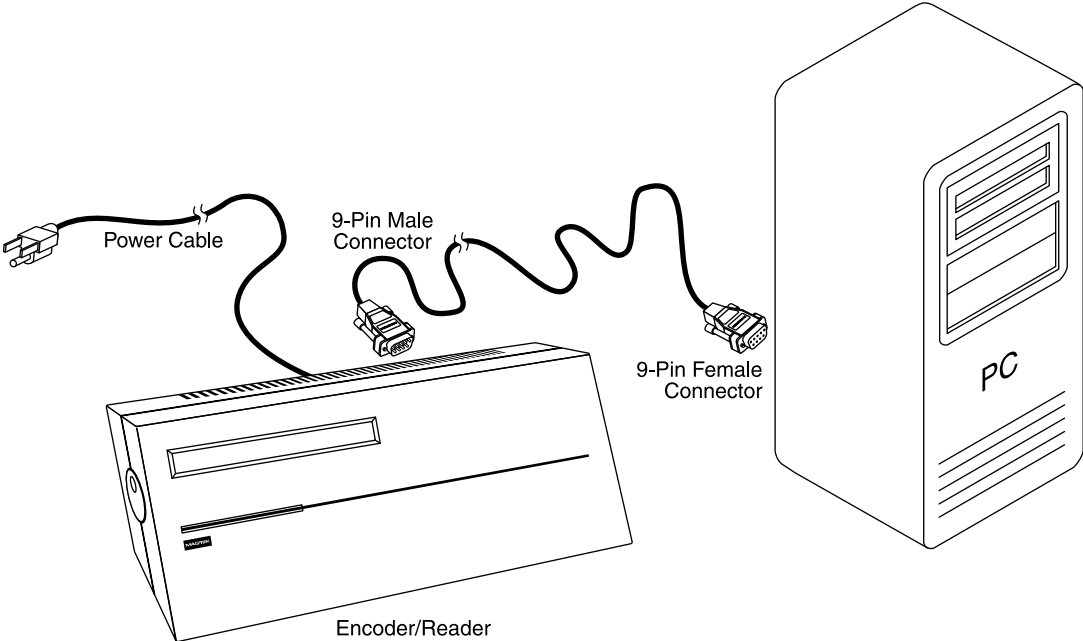

Figure 2-3. Encoder to PC Connection

To setup the Encoder, perform the following steps:

1. On the keyboard, type **S**. The display will be:

```
Select option to change      Esc=exit
T)racks S)erial E)ncode M)ode C)ard Time
```

2. Type **T**, and the display will be:

```
Select tracks to enable      Enter=done
Track: 1Y 2Y 3Y  A)ll
```

Type **1, 2,** or **3** to toggle each track between **Yes** and **No**. When **A** is selected, all three tracks will be set to on (Y). For example, the above display shows all three tracks enabled. If **1** and **3** are pressed, these two tracks will toggle off, and only Track 2 will be enabled. Select the tracks to enable and press **Enter**.

Note

This setup affects card encoding only. During a card read, any tracks with data will be displayed (and transmitted if online).

3. When **Enter** is pressed, the program will return to the following display:

```
Select option to change      Esc=exit
T)racks S)erial E)ncode M)ode C)ard Time
```

Type **S** and the next display will be:

```
Select online baud rate      Enter=done
1=300 2=600 3=1200 4=2400 5=4800 6=9600
```

The current setting will be indicated by a flashing cursor on one of the numbers. Press 1, 2, 3, 4, 5, or 6 to highlight the baud rate and **Enter** to select it. The default is **9600**. The default parameters are listed in Table 2-1. To retain the **9600** baud rate, press **Enter** when **6** is highlighted. If **Esc** is pressed, the original baud rate will remain in effect.

Table 2-1. Default Parameters

Parameter	Description
Baud rate	9600
Parity	Even
Data Bits	7 (Even or Odd parity is always 7 bits; no parity is always 8 bits)
Stop Bits	1
Coercivity	Auto - When a card is encoded, the program automatically selects High or Low coercivity
Tracks	1, 2, and 3 are enabled

4. When **Enter** is pressed, the LCD will display:

```
Select online data parity      Enter=done
N)one[8 bit] O)dd[7 bit] E)ven[7 bit]
```

Press **N**, **O**, or **E** to highlight the parity setting and **Enter** to select it. The default is odd. If **Esc** is pressed, the original parity value will remain in effect.

5. The next display is:

```
Select online stop bits      Enter=done
1)Stop bit      2)Stop bits
```

Press **1** or **2** to highlight the stop bits setting and **Enter** to select. The default is 1. If **Esc** is pressed, the original stop bit setting will remain in effect.

6. When **Enter** is pressed, the program will return to the following display:

```
Select option to change      Esc=exit
T)racks S)erial E)ncode M)ode C)ard Time
```

Type **E** and the display will be:

```
Select encode coercivity      Enter=done
H)igh L)ow A)uto
```

A HiCo card is harder to erase than a LoCo card, which can be erased by a small magnet. Auto is a MagTek proprietary encoding technique that determines if the card is HiCo or LoCo.

When encoding a HiCo card in the Auto Mode, the card will always require two passes before it is encoded. If all cards to be encoded are HiCo, this parameter should be set to **H)igh**.

Press **H** or **L** to select high or low coercivity and **A** to select Auto. After selecting, press **Enter**. If **Esc** is pressed, the original encode setting will remain in effect.

7. When **Enter** is pressed, the program will return to the following display:

```
Select option to change          Esc=exit
T)racks S)erial E)ncode M)ode C)ard Time
```

Type **M** and the display will be:

```
Select online encode mode      Enter=done
N)ormal S)ecure
```

Type **N** or **S** to highlight the Encode mode and press **Enter** to select it. Each mode allows reading and encoding cards.

Normal Mode

In the Normal Mode, the MT-95 operates as a simple card reader and card encoder. When a card is inserted and swiped, all track information will be transmitted via the RS-232 connection to the PC. After the card has been successfully read, the card should be removed from the slot. If a card is to be encoded, the PC will prepare the track data and transmit it to the Encoder. The unit will then beep and prompt for a card to be inserted into the slot for encoding.

This mode is selected from the PC by sending the “/N” command. This mode is compatible with the MagTek MT-80 software.

Secure Mode

In some applications it may be necessary to ensure that the information that is encoded onto a card goes back onto the same card that it came from. This may occur in a financial institution when a customer’s card is read and only a portion of the track data is modified, such as with a PIN change. In this case the MT-95 will ensure that the card is not removed from the unit between the read and encode operations. This will help to prevent *skimming* of cards.

If the card is removed before the encode operation, the unit will send an error message (M) indicating that the card has been moved and the operation has been aborted. The secure mode is selected from the PC by sending the “/S” command.

8. When **Enter** is pressed, the Setup menu will be shown:

```
Select option to change          Esc=exit
T)racks S)erial E)ncode M)ode C)ard Time
```

Type **C** to define the card timeout. The following menu will be shown:

```
Type in Encode Timeout: [Ins] Enter=done
000 Seconds (Max=255, 0=Disable Timeout)
```

If the timeout value is zero, an encode function will never time out. If any other value (from 1 to 255) is selected, an encode operation will time out after the specified number of seconds. Additionally, if the value is non-zero, the encode operation will be aborted if a card is inserted and removed without completing the encode. If the timeout is set to zero (000), a card may be inserted and removed or an encode may be attempted for an unlimited number of attempts until successful.

After entering the desired value, press **Enter**. If you do not wish to change the value, press **Esc**.

9. From the Setup Menu, there is one hidden command. When the Setup Menu appears, press **6** and the following appears:

```
Select read status          Enter=done
S)how status          D)on't show status
```

The default is **D)on't show status**. If **D** is selected and an error occurs, a normal display will be similar to the following:

```
**Did not encode properly. Try again.**
--> Slide card right when ready -->
```

If **S** is selected and an error occurs during encoding, a display similar to the following will appear:

```
**Did not encode properly. Try again.*07
--> Slide card right when ready -->
```

The 07 is the read-after-write status. The read status values are as follows:

Binary Number	Description
01	Error on Track 1
02	Error on Track 2
04	Error on Track 3
10	Blank Track 1
20	Blank Track 2
40	Blank Track 3

The resulting value is the sum of these binary numbers; for example, 43 indicates that Track 3 is blank (40) and errors were detected on Tracks 1 and 2 (01 + 02 =03). If Track 1 is blank and Tracks 2 and 3 contain errors, the number is 16.

Setup - IntelliCoder

The IntelliCoder is configured in the factory prior to shipment. There are no setup options required.

Refer to Section 4 for a description of the online operation.

SECTION 3. STANDALONE OPERATION

This section describes card reading, copying, and encoding which are basic to operating the Encoder with a keyboard. After the self test and version displays, the main menu will appear:

```
                Select a card operation
R)ead      C)opy      E)ncode      S)etup
```

Ensure the Setup operation, as described in Section 2, is completed before proceeding.

CARD READING AND ENCODING FUNDAMENTALS

To read a card, either just insert a card for reading or select **R** from the main menu shown above, and the following will appear:

```
                Insert card for reading
                or press Esc to exit
```

Hold the card firmly in the middle with the magnetic stripe down (toward the bottom of the encoder). Insert the card into either end of the encoder slot. The display will indicate the direction the card should be moved; for example, if the card is inserted in the right side:

```
<-- slide card left when ready <--
```

After the card has been moved to the other end of the slot (this is called “swiping the card”), the display will indicate whether the card was successfully read or not. If the read was bad, the card must be swiped again to reread the data. The card may be swiped as often as needed to get a good read. There is no limit on the number of retries.

If a card is to be encoded, there must be information in the buffer for each track to be encoded. Select **E** from the main menu, then select **1) Free Format** then **E**, and if there is no data in the buffer, the following will appear:

```
                Select an operation                Esc=exit
                No data to encode.
```

To encode, either read a card as described above, or manually enter data with a keyboard. Then select **E** from the main menu. Then Select **1) Free Format** from the following:

```
                Select encoding type                Esc=exit
                1) Free Format                2)Fixed Format
```

Then select **E)ncode** from the following:

```
Select an operation          Esc=exit
Tk:1* 2* 3*  E)ncode card  C)lear tracks
```

If all three tracks are encoded, the following display will appear:

```
Encoding data on tracks 1 2 3
Insert card for encoding      (Auto)
```

Auto indicates that the Encoder will encode in either HiCo or LoCo (high coercivity or low coercivity). Auto is a MagTek proprietary technique that determines if the card is HiCo or LoCo. Insert the card in the left side, and following will appear:

```
Encoding data on tracks 1 2 3
-->Slide card right when ready-->
```

After the card is swiped from left to right, the following sequence may occur:

1.

```
Encoding data on tracks 1 2 3
<- Slide card left when ready (LoCo)<-
```

The first attempt is to encode a LoCo card. If the card does not encode at LoCo, there will be an attempt at HiCo.

2.

```
This may be a HiCo card. Try again.
-> Slide card right when ready ->
```

3.

```
Encoding data on tracks 1 2 3
<- Slide card left when ready (HiCo) <-
```

If the card is HiCo and encodes properly, the following will appear:

```
*** CARD ENCODED CORRECTLY ***
Remove the card
```

If, at any time during the sequence, the card did not encode properly, the display is as follows:

```
**Did not encode properly. Try again.**
--> Slide card right when ready -->
```

If a card is swiped before the unit is ready to encode, the following will appear:

*** Card was swiped before encoder ready *
->Slide card right when ready->**

Other messages that may appear are as follows:

Cannot encode card (check orientation)

The card may be inserted upside down. Ensure the stripe is facing down and parallel to the slot.

No data to encode

At least one card must contain data before a card can be encoded.

Track 1 is too long.

Too much data has been entered on a track. This applies to Track 2 and 3 as well. This can only occur when operating online.

This is not a valid Format Card

Ensure Format Card is used. It must have variable data entries.

Only ISO encoded cards can be copied.

Cards in other formats cannot be copied (a driver license, for example).

Time elapsed. Remove card.

or

Timeout waiting for card to be swiped

A timeout occurred before the card was swiped.

CARD READING

To read a card, select **R** from the main menu or simply swipe a card from left to right. If there is data on all three cards, a display similar to the following will appear:

```
Press: 1 2 3 to view tracks    Esc=exit  
Card encoded in ISO format
```

If Track 3 is selected, a display similar to the following example will appear:

```
Tk3:001-039  Scr1→ Enter=next  Esc=exit  
+011234567890123456=1234567890123456=123
```

The first entry, **Tk3:001-039**, indicates that positions 1 through 39 on the second line are shown on the LCD. The start sentinel and end sentinel are never included in the position indicator. The **Scr1** and the arrow indicate the direction of scroll. Press the arrow key to scroll in the direction of the arrow key on the screen. To view the beginning or end of the track, hold down the **Fn** key while pressing the **Home** or **End** key. **Enter=next** means press the **Enter** key to view the next track (Track 1 will follow Track 3). **Esc=exit** means press the **Esc** key to return to the previous LCD screen.

CARD COPYING

To copy cards, follow these steps:

1. When in the Main Menu, press **C** on the keyboard. The following display will appear:

**Insert the original card
or press Esc to exit**

2. Insert the card from which the other cards will be copied. The display will be:

--> Slide card right when ready -->

3. Slide the card, and if the read is good, the following will appear:

**ISO format data read on tracks 1 2 3
Remove the card**

4. Remove the card and the following will appear:

**Insert next card to encode
or press Esc to exit**

5. Insert the card to be encoded and the display will be:

**Encoding data on tracks 1 2 3
-> Slide card right when ready ->**

6. After the card has been swiped from right to left to encode the card, a read-after-write operation is performed. If the card was correctly encoded, the display will be:

***** CARD ENCODED CORRECTLY ***
Remove the Card**

Remove the card.

To copy a series of cards, repeat steps 4, 5, and 6.

CARD ENCODING

When a keyboard is used, data is keyed into the buffers for encoding, or data can be copied from another card. Encoding always takes place when the card is swiped from the right end of the slot to the left end. When **E** is selected from the main menu, the display will read:

```
      Select encoding type          Esc=exit
      1) Free Format                2)Fixed Format
```

Free Format allows any legal data to be placed anywhere on the tracks. (Legal data, for example, may be any alphanumeric data on Track 1 but only numeric data on Tracks 2 and 3.) Fixed Format defines constant and variable data on one or more tracks. In Fixed Format the operator can create a Format (or template) card which, when used, allows the variable fields to be filled in.

Free Format Encoding

If **1** is pressed, a display similar to the following will appear:

```
      Select an operation          Esc=exit
      Tk:1* 2* 3*  E)ncode card  C)lear tracks
```

The asterisks after the track numbers indicate that there is data on that track. In the above there is data on all three tracks. To become familiar with Free Format Encoding, follow these steps:

1. To select Track 1, press **1** on the keyboard. An example of a Track 1 display is as follows:

```
      TK1:001   F1=FS             Ins  Enter=done
      %A12345^JKL^SARAH SMITH^1234567890?
```

TK1:001 indicates the track and the position of the cursor. In this example the cursor is on the first character (**A**). To place the cursor at the end of the track, press the right arrow key to scroll to the end or press and hold **Fn** and press the **End** key. The cursor will then flash on the **?**, which is a symbol for the end of the track.

Note

Neither the start sentinel nor the end sentinel can be modified; they are automatically placed on the track.

F1=FS means press **F1** to insert a Field Separator. There are three in the above example. The **Ins** key is located in the top row of the keyboard next to the **Delete** key (at the extreme right). When the **Ins** key is pressed, the display toggles between **Ins** (Insert) and **Ovr** (Overstrike). This key permits a character to be inserted or overstruck with another character. **Enter=done** means press **Enter** when the change to the track is complete. If anything else is pressed such as **Esc**, the change will not occur.

- To change **^JKL^** in the example above to **^MNOP^**, press the **Ins** key until **Ovr** is showing on the LCD. Position the cursor over the **J**. Type **MNO**. Press the **Ins** key until **Ins** shows on the LCD and type **P**. The result is **MNO** replaced **JKL** and the **P** has been added in the field. Press **Enter** to return to the Free Format display.

```
Select an operation          Esc=exit
Tk:1* 2* 3*  E)ncode card  C)lear tracks
```

- If only one or two tracks are to be encoded, press **C** to clear tracks:

```
Select tracks to clear      Enter=done
Track: 1=no 2=no 3=no      A)ll N)one
```

The selections of numbers and letters act as toggle switches. In this example tracks will clear separately by pressing **1**, **2**, or **3**. Pressing **A** will clear all tracks. No tracks will be cleared if **N** is pressed. Press **A** and the following appears:

```
Select tracks to clear      Enter=done
Track: 1=YES 2=YES 3=YES    A)ll N)one
```

- Press **Enter** and the following appears:

```
Press 'C' to clear tracks 1 2 3
or any other key to cancel
```

Press **C** to complete the clear tracks operation.

- When **Select an operation**, press **E** and if there is no data in the buffer, the display will be:

```
Select an operation          Esc=exit
No data to encode.
```

Press **E** and if there is data in the buffer, the display will be:

```
      Encoding data on tracks 1 2 3
Insert the card for encoding      (Auto)
```

(Auto) is a reminder that the setup is for auto mode. Immediately after the card is encoded, it is read and verified with the data entered into the buffer from the keyboard. If the encode data and read data compare, the encoder will indicate a good encode by displaying:

```
*** CARD ENCODED CORRECTLY ***
      Remove the card
```

If the card did not encode correctly, the display may show:

```
**Did not encode properly. Try again.**
-> Slide card right when ready ->
```

or if the card is HiCo:

```
This may be a HiCo card. Try again.
-> Slide card right when ready ->
```

Swipe as required.

Fixed Format Encoding

From the Main Menu select **E)ncode**, or press Esc until the following menu appears:

```
      Select encoding type                Esc=exit
1) Free Format                          2)Fixed Format
```

Fixed Format Encoding permits the user to create a format card from which a sequence of cards can be easily encoded. To become familiar with the Fixed Format, follow these steps:

1. From the Select encoding type menu, press **2** for Fixed Format options:

```
      Select an operation                Esc=exit
      E)ncode cards      C)reate Format Card
```

If a Format Card exists, go to step 2. If a Format Card does not exist, go to Create Format Card, below.

2. Press **E**, and the display will be:

**Please swipe a Format Card
or press Esc to exit**

Read a previously encoded Format Card and remove it. The following display appears:

**Ready for data entry...
Remove the card**

When the card is removed, the following appears:

**Enter track:1 Pos:007 Esc=exit
%A12345---^SARAH SMITH^1234567890?**

Track 1 is ready for encoding, and Position 7 is where the first variable character will be encoded. The cursor will remain on Position 7 until a character is typed.

3. Type **678** to fill in all variable locations. When all locations on all tracks have been filled, the following display will appear on the first line:

Insert card to encode Enter=review

To verify the data that has been entered, press **Enter** and the following appears:

**Insert card to encode Enter=review
1)%A12345678^SARAH SMITH^1234567890?**

The **1)** indicates that on Track 1 **678** have been added.

4. Insert a card to encode on the left side, and the following will appear:

**Encoding data on track 1
->Slide card right when ready ->**

5. Swipe the card and if encoding is successful, the following will appear:

***** CARD ENCODED CORRECTLY ***
Remove the card**

or if the card is HiCo:

This may be a HiCo card. Try again
--> Slide card right when ready -->

Swipe as required.

6. Remove the card, and encode other cards in the same manner.

Create Format Card

From the main menu press **E)ncode**, then **2)Fixed Format** or Press Esc until the following menu reappears:

```
Select an operation          Esc=exit
E)ncode cards      C)reate Format card
```

To create a format card (as the one used above), proceed as follows:

1. Press **C** to create a Format Card, and the following appears:

```
Select an operation          Esc=exit
Tk:1* 2 3      E)ncode card  C)lear tracks
```

2. The asterisks in the above menu indicate that there is data in Track 1. To remove the data, press **C** and the following appears:

```
Select tracks to clear      Enter=done
Track: 1=no 2=no 3=no      A)ll N)one
```

The selections of numbers and letters toggle **Yes** and **no**. In this example tracks may be cleared separately by pressing **1**, **2**, or **3**. Pressing **A** will clear all tracks. No tracks will be cleared if **N** is pressed. Press **A** and the following appears:

```
Select tracks to clear      Enter=done
Track: 1=YES 2=YES 3=YES      A)ll N)one
```

3. Press **Enter** for the following display:

```
Press 'C' to clear tracks 1 2 3
or any other key to cancel
```

The purpose of this display is to reaffirm clearance of the correct tracks.

4. Press **C** and the following appears:

```
Select an operation          Esc=exit
Tk:1  2  3  E)ncode card  C)lear tracks
```

This display indicates that all three tracks are empty.

5. Press **1** for encoding Track 1 and the following appears:

```
Tk1:001  F1=FS  F3=Var  Ins  Enter=done
%?
```

The cursor will be flashing on the symbol for the end of track (?); this is position 001. **F1=FS** means press **F1** to insert a Field Separator. **F3=Var** means press **F3** to insert a blank for a variable character.

When the **Ins** key is pressed, the display toggles between **Ins** and **Ovr**. This key permits a character to be inserted or overstruck with another character. **Enter=done** means press **Enter** when the change to the track is complete.

6. Type the following (ignore the spaces except between the two names): **A12345 F3 F3 F3 F1 SARAH SMITH F1 1234567890**. **F1** and **F3** are function keys at the top of the keyboard. This should appear as:

```
%A12345---^SARAH SMITH^1234567890?
```

This information will be encoded on the Format Card.

7. Press **Enter**, and the following display will appear:

```
Select an operation          Esc=exit
Tk:1*  2  3  E)ncode card  C)lear tracks
```

To review the information, press **1**, and after the review press **Enter**.

8. To encode the Format Card, press **E** and follow the prompts. After the Format Card has been successfully encoded, mark it as a Format Card so it can be easily identified when encoding fixed format cards

SECTION 4. ONLINE CARD OPERATION

This section describes the online operation of reading and writing fundamentals, card data messages, and examples when the Encoder is used with a PC or terminal. Specific track information is also listed. The Encoder must be connected to a PC *and* the DTR line (see Appendix A) must be active to receive commands and data from the PC. (As an option, MagTek offers the MT-80 Program P/N 15030402, Manual P/N 99815005.)

Ensure that the MT-95 and the PC are set to the same communication parameters. The settings on the MT-95 can only be changed with a keyboard attached (see Section 2, Installation and Setup). If the parameters do not correspond, the MT-95 may beep when a character is received. The default settings are 4800 baud, odd parity, 1 stop bit.

CARD READING

In the online mode, the display will show either **Normal Mode** or **Secure Mode** on the top line, followed by **Insert card for reading**. To read a card, hold the card firmly in the middle with the magnetic stripe down (toward the bottom of the encoder). Insert the card into either end of the encoder slot. The display will indicate the direction the card should be moved; for example, if the card is inserted in the right side:

<- Slide card left when ready <-

After the card has been moved to the other end of the slot (this is called “swiping the card”), the display will indicate whether the card was successfully read or not. If the read was bad, the card must be swiped again to reread the data. The card may be swiped as often as needed to get a good read. There is no limit on the number of retries.

CARD ENCODING

To encode a card on a PC system, the PC must first transmit the data to be encoded on the card to the Encoder. If all three tracks are to be encoded, the following display will appear:

Encoding data on tracks 1 2 3
Insert card for encoding (Auto)

Auto indicates that the Encoder will encode in either HiCo or LoCo (high coercivity or low coercivity). Auto is a MagTek proprietary technique that determines if the card is HiCo or LoCo. Insert the card in the left side, and following will appear:

Encoding data on tracks 1 2 3
-> Slide card right when ready ->

MT-95 RS-232 HiCo/LoCo Encoder/Reader

When the card is swiped from left to right, and it is a HiCo card, the following sequence may occur:

1.
 Encoding data on tracks 1 2 3
 -> Slide card right when ready ->
2.
 Encoding data on tracks 1 2 3
 <- Slide card left when ready (LoCo) -<
3.
 ** This may be a HiCo card, try again **
 -> Slide card right when ready ->
4.
 Encoding data on tracks 1 2 3
 <- Slide card left when ready (HiCo) -<
5.
 *** CARD ENCODED CORRECTLY ***
 Remove the card

If a card is swiped before the unit is ready to encode, the following will appear:

```
* Card was swiped before encoder ready *  
->Slide card right when ready->
```

After the card has been encoded, the MT-95 will transmit the data from the track(s) just encoded back to the PC. Thus, if all three tracks have valid data but only Track 2 is encoded in this operation, only Track 2 data will be returned to the PC. This provides an indication that the card has been encoded correctly.

SECTION 5. ONLINE PROGRAMMING

Refer to this section if user-developed software is to be used. If MagTek Software is to be used, refer to *Model MT-80 RS-232 Magnetic Stripe Encoder Software Installation and Operation Manual*, P/N 99815005. This section contains encoded message formats, examples, online commands, online encoded track formats, online modes, and track character sets.

Note

In this section, the ASCII values from 0x00 to 0x1F (hex) are represented by their respective mnemonics enclosed in brackets (for example, the hex value 02, Start Of Text, has the mnemonic “STX” and is shown as <STX>).

ENCODED MESSAGE FORMAT

The format of the encoded data for three tracks is as follows:

<STX> <SS> track data <ES> <SS> track data <ES> <SS> track data
<ES> <ETX>

where: <STX> is the Start of Text character (0x02, or control B on the keyboard). This character puts the encoder into the encode mode and prepares it to receive the track data.

<SS> is the Start Sentinel for each track to be encoded. Each track of card data must start with its identifying Start Sentinel and end with an End Sentinel (which is always a question mark (?)). You may encode any combination of the three tracks. The order that they are sent does not matter. For example, track three can be sent first, then track one or track one then track three. The Start Sentinels are as follows:

Track	SS	Symbol	Format
1	%	(percent sign)	7-bit format
2	;	(semicolon)	5-bit format
3	+	(plus sign)	5-bit format
3	%	(percent sign)	7-bit format (Read only)*

* This device does not encode 7-bit format on Track 3.

- track data** is the actual data to be encoded on each track. These must be legal characters for that track. That is, you cannot encode letters on Tracks 2 and 3 in 5-bit format, so these should not be sent.
- <ES>** is the End Sentinel for each track encoded. The End Sentinel is a question mark (?) for all three tracks. This must end each set of track data.
- <ETX>** is the End of Text character (0x03), or control C on the keyboard). When this character is received by the encoder, it will switch to the encode mode until either a successful encode or an abort character is received.
- <CR>** Carriage Return (0x0D)
- <LF>** Line Feed (0x0A)
- <SP>** Space (0x02)

ENCODE COMMAND IN SECURE MODE

If an encode command is sent to the MT-95 while it is in the Secure Mode but the read operation has not been done yet, the MT-95 will return then following:

Command type	Response
Single track encode data {SS}[DATA]{ES}	<STX><NAK><ETX> >
Multi-track encode data <STX>{SS}[DATA]{ES}{SS}[DATA]{ES}<ETX>	<STX><NAK><ETX> >
Software Encode Command [W...	<STX>S0000<ETX>

PC ENCODED EXAMPLE

To encode “ABCDEFGH” on Track 1 and “123456789=112233” on Track 2 and keep Track 3 the same, the data to the encoder is:

<STX>%ABCDEFGH? ;123456789=112233?<ETX>

The STX character shows on the computer’s screen as a “happy face” (on some systems it might appear as \$02). The ETX character shows on the computer’s screen as a heart (on some systems it might appear as \$03). It is not necessary to send a carriage return after the ETX. With this command, Tracks 1 and 2 will be encoded. Track 3 will be left as it is.

ONLINE COMMANDS

The following notes apply to Online Commands:

1. All commands begin with a forward slash “/” (0x2F) or “[” which are followed by one or more characters (case insensitive). The commands are executed upon receipt of the last character.
2. The response to the messages is an ACK message. This message has the following format:

`<STX><ACK><ETX>` (0x02 0x06 0x03.)
3. If an illegal command is sent, the response will be `<STX><NAK><ETX>`
(0x02 0x15 0x03.)

The commands are as follows:

Note

All commands are case insensitive.

Change Encode Coercivity Mode

- `/L` = switch to LoCo only mode
- `/H` = switch to HiCo only mode
- `/A` = switch to Automatic Selection Mode

Change Online Encode Mode

- `/S` = Secure mode on (the Encoder must do a good read before it will accept an encode command)
- `/N` = Normal mode - Secure mode off (the Encoder can do an encode at any time)
- `/Mn` = Software Controlled Mode enable where n=“0” (0x30) – Disable, “1” (0x31) – Enable
- `[W` = Alternate encode command that returns a status indicating type of encode, number of swipes needed, and encode results
- `[R` = Software Controlled Read
- `[U` = Set/Retrieve Device Serial Number

Change Display

- `[I` = Idle message, top and, optionally, bottom line
- `[J` = Idle message, bottom line
- `[N` = Software encode message – replaces the insert card message during an encoder operation.
- `[O` = Display immediate. Updates the display with the supplied message.

ONLINE ENCODE FORMATS (NON-SOFTWARE MODE)

If more than one track is to be encoded, the track information must be enclosed in an <STX>/<ETX> bracket (<STX> data <ETX>).

% data ?	=	Track 1 ISO data	(6 data bits, 1 odd parity bit)
; data ?	=	Track 2 ISO data	(4 data bits, 1 odd parity bit)
+ data ?	=	Track 3 ISO data	(4 data bits, 1 odd parity bit)

These Start sentinel values (“%”, “;”, “+”) are used by the Encoder to determine which track to put the data on. The actual encoded start sentinels are as follows:

Track 1:	%
Track 2:	;
Track 3:	; (for 5-bit data)

Examples are as follows:

Example 1:

Encode track 3 only with “123456” in ISO format (tracks 1 and 2 will not be affected):

+123456?

(the hex values are 2b 31 32 33 34 35 36 3f)

No carriage return, line feed or any other character need be sent. The Encoder will switch to write mode when it receives the question mark.

Example 2:

Encode tracks 1 and 3 with “ABC” and “123” respectively (track 2 will not be affected):

<STX>%ABC?+123?<ETX>

The hex values are 02 25 41 42 43 3f 2b 31 32 33 3f 03

No carriage return, line feed or any other character need be sent. The Encoder will switch to write mode when it receives the <ETX>.

ONLINE MODES

There are three modes of online operation: normal encode, software controlled, and secure encode. Each mode allows reading and encoding cards.

Normal Mode

In the Normal Mode, the MT-95 operates as a simple card reader and card encoder. When a card is inserted and swiped, all track information will be transmitted via the RS-232 connection to the PC. After the card has been successfully read, the card should be removed from the slot. If a card is to be encoded, the PC will prepare the track data and transmit it to the Encoder. The unit will then beep and prompt for a card to be inserted into the slot for encoding.

This mode is selected from the PC by sending the /N command. This mode is compatible with the MagTek MT-80 software.

Software Controlled Mode

Purpose: To enable or disable Software Controlled Read Mode. If this mode is enabled, then the read function will not activate until an [R command is received. If this mode is disabled, then the read function will activate when the encoder comes on-line (i.e., DTR is asserted). The default is Disabled.

Command Format Mode: /M

Type	Field	Length	Comments
/	Command prefix	1	Forward slash, ASCII 0x2F
M	Command	1	Case insensitive, use M (0x4D) or m (0x6D)
[MODE]	Parameter	1	Software control mode value: '0' (0x30) – Disable '1' (0x31) – Enable '=' (0x3D) – returns current settings as <STX>[MODE]<ETX> where [MODE] is '0' or '1' as above.

Responses:

After legal /M0 or /M1: <STX><ACK><ETX>

After legal /M=: <STX>[MODE]<ETX>

After any other value after /M: <STX><NAK><ETX>

Secure Mode

In some applications it may be necessary to ensure that the information that is encoded onto a card goes back onto the same card that it came from. This may occur in a financial institution when a customer's card is read and only a portion of the track data is modified, such as with a PIN change. In this case the MT-95 will ensure that the card is not removed from the unit between the read and encode operations. This will help to prevent *skimming* of cards.

If the card is removed before the encode operation, the unit will send an error message indicating that the card has been moved and the operation has been aborted. The error message is:
<STX>M<ETX> .

This mode is selected from the PC by sending the “/S” command.

TRACK CHARACTER SETS

Tables 4-1 and 4-2 show Track 1/3 and 2/3 character sets. In these tables the following mnemonics are used:

- (SS) = Start Sentinel
- (ES) = End Sentinel
- (FS) = Field Separator

Table 4-1. Track 1/3 7-Bit Character Set

Character	Hex	Character	Hex	Character	Hex	Character	Hex
Space	20	0	30	@ at sign	40	P	50
! exclamation mark	21	1	31	A	41	Q	51
" double quote	22	2	32	B	42	R	52
# pound sign	23	3	33	C	43	S	53
\$ dollar sign	24	4	34	D	44	T	54
% (SS) per cent sign	25	5	35	E	45	U	55
& ampersand	26	6	36	F	46	V	56
' apostrophe	27	7	37	G	47	W	57
(left paren	28	8	38	H	48	X	58
) right paren	29	9	39	I	49	Y	59
* asterisk	2a	: colon	3a	J	4a	Z	5a
+ plus sign	2b	; semi-colon	3b	K	4b	[left square bracket	5b
, comma	2c	< left bracket	3c	L	4c	\ back slash	5c
- hyphen	2d	= equal sign	3d	M	4d] right square bracket	5d
. period	2e	> right bracket	3e	N	4e	^ (FS) carat	5e
/ forward slash	2f	? (ES) question mark	3f	O	4f	_ underline	5f

Table 4-2. Track 2/3 5-Bit Character Set

Character	Hex	Character	Hex	Character	Hex	Character	Hex
0	30	4	34	8	38	< left bracket	3c
1	31	5	35	9	39	= (FS) equal sign	3d
2	32	6	36	: colon	3a	> right bracket	3e
3	33	7	37	; (SS) semi-colon	3b	? (ES) question mark	3f

IDLE MESSAGE

Purpose: The Idle Message commands now apply to the standard encode/read mode as well as the IBM mode. If the software mode is active (/M1) these messages will be immediately displayed.

Top and Bottom Line

```
[I [MSG1] <FS> [MSG2] <ETX>
```

Type	Field	Length	Comments
[Command prefix	1	ASCII 0x5B
I	Command	1	case insensitive, use I (0x49) or i (0x69)
[MSG1]	Parameter	0 to 40	Idle Message, top line, ASCII values 0x20 (space) to 0x7E (~). If no data provided, then the top line is set to the default value.
<FS>	Command separator	1	(optional) If present, following data is copied to the bottom line. If no following data, then bottom line set to default value.
[MSG2]	Parameter	0 to 40	Idle Message, bottom line, ASCII values 0x20 (space) to 0x7E (~)
<ETX>	Command Terminator	1	0x03

Example 1: Set idle message for the top line to “First ABC Bank”.

```
ASCII:  [IFirst ABC Bank♥
BASIC:  “[IFirst ABC Bank” + Chr$(3)
C:      “[IFirst ABC Bank\x03”
Hex:    5B 49 46 69 72 73 74 20 41 42 43 20 42 61 6E 6B 03
```

Example 2: Set idle message for the top line to “Navy Federal Credit Union”. Set the idle message for the bottom line to “60 years of faithful service”.

```
ASCII:  [INavy Federal Credit Union^60 years of faithful service♥
BASIC:  “[INavy Federal Credit Union” + Chr$(28) + “60 years of faithful
service” + Chr$(3)
C:      “[INavy Federal Credit Union\x1C60 years of faithful service\x03”
Hex:    5B 49 4E 61 76 79 20 46 65 64 65 72 61 6C 20 43 72 65 64 69 74 20 55
6E 69 6F 6E 1C 36 30 20 79 65 61 72 73 20 6F 66 20 66 61 69 74 68 66
75 6C 20 73 65 72 76 69 63 65 03
```

Bottom Line

[J [MSG] <ETX>

Type	Field	Length	Comments
[Command prefix	1	ASCII 0x5B
J	Command	1	case insensitive, use J (0x4A) or j (0x6A)
[MSG]	Parameter	0 to 40	Idle Message, top line, ASCII values 0x20 (space) to 0x7E (~)
<ETX >	Command Terminator	1	0x03

Example: Set idle message for the bottom line to “Best in the West”.

ASCII: [JBest in the West♥
BASIC: “[JBest in the West” + Chr\$(3)
C: “[JBest in the West\x03”
Hex: 5B 4A 42 65 73 74 20 69 6E 20 74 68 65 20 57 65 73 74 03

DISPLAY IMMEDIATE

Purpose: This command immediately updates the display with the supplied message. The message will either stay until another command or operation changes the display or, if the timeout [DT] value is non-zero, for a specific period of time (1 to 255 seconds).

Command format: [O [DT] <FS> [MSG1] <FS> [MSG2] <ETX>

Type	Field	Length	Comments
[Command prefix	1	ASCII 0x5B
O	Command	1	case insensitive, use O (0x4F) or o (0x6F)
[DT]	Parameter	0 to 3	Display time, decimal, range 0 to 255
<FS>	Separator	1	0x1C, parameter separator
[MSG1]	Parameter	0 to 40	(optional) Message for the top line, ASCII values 0x20 (space) to 0x7E (~)
<FS>	Separator	1	(optional) 0x1C, parameter separator, required if [MSG2] sent
[MSG2]	Parameter	0 to 40	(optional) Message for the bottom line, ASCII values 0x20 (space) to 0x7E (~)
<ETX>	Command Terminator	1	0x03

Example: Display “First National Bank” on the top line and “We aim to please” on the bottom line for 10 seconds.

ASCII: [O10^LFirst National Bank^LWe aim to please^v

BASIC: “[O10” + Chr\$(28) + “First National Bank” + Chr\$(28) + “We aim to please” + Chr\$(3)

C: “[O10\x1CFirst National Bank\x1CWe aim to please\x03”

Hex: 5B 4F 31 30 1C 46 69 72 73 74 20 4E 61 74 69 6F 6E 61 6C 20 42 61 6E
6B 1C 57 65 20 61 69 6D 20 74 6F 20 70 6C 65 61 73 65 03

ENCODE COMMAND WITH STATUS RESPONSE

Purpose: Alternate encode command that returns a status indicating type of encode, number of swipes needed and encode results. The optional parameter [CF] causes the encoder to temporarily switch to the specified encode mode during this transaction.

Command format:[W [CF] [TRK1] [TRK2] [TRK3]

Type	Field	Length	Comments
[Command prefix	1	ASCII 0x5B
W	Command	1	case insensitive, use W (0x57) or w (0x77)
[CF]	Parameter	0 or 1	Encode coercivity override (optional) 'A' (0x41) or 'a' (0x61) – Encode in AutoMode 'H' (0x48) or 'h' (0x68) – Encode in HiCo 'L' (0x4c) or 'l' (0x6c) – Encode in LoCo
[TRK1]	Parameter	0 or 2 to 78	Track 1 data (optional) Must begin track 1 Start Sentinel ('%', 0x25) and finish with the End Sentinel ('?', 0x3F)
[TRK2]	Parameter	0 or 2 to 39	Track 2 data (optional) Must begin track 2 Start Sentinel (':', 0x3B) and finish with the End Sentinel ('?', 0x3F)
[TRK3]	Parameter	0 or 2 to 106	Track 3 data (optional) Must begin track 2 Start Sentinel ('+', 0x2B) and finish with the End Sentinel ('?', 0x3F)

Example: Encode the following in AutoSelect Coercivity mode:

Track 1: **"TRACK 1 DATA"**
 Track 2: **"222=222=222"**
 Track 3: **"3=3=3"**

Command:

ASCII: **[WA%TRACK 1 DATA?;222=222=222?+3=3=3?<insert heart symbol>**
 BASIC: **"[WA%TRACK 1 DATA?;222=222=222?+3=3=3?" & Chr\$(3)**
 C: **"[WA%TRACK 1 DATA?;222=222=222?+3=3=3?\x03"**
 Hex: **5B 57 41 25 54 52 41 43 4B 20 31 20 44 41 54 41 3F 3B 32 32 32 3D**
 32 32 32 3D 32 32 32 3F 2B 33 3D 33 3D 33 3F 03

Command accepted response:

ASCII: **☺ ♠ ♥**
 BASIC: **Chr\$(2) & Chr\$(6) & Chr\$(3)**
 C: **"\x02\x06\x03"**
 Hex: **02 06 03**

After a successful encode:

ASCII: ●L1000♥
BASIC: Chr\$(2) & L1000 & Chr\$(3)
C: "\x02L1000\x03"
Hex: 02 4C 31 30 30 30 03

Example of invalid characters in encode data:

Track 1: "111"
Track 2: "222X" (X is illegal for track 2)
Track 3: "3333"

Command:

ASCII: [WA%111?;222X?+3333?<insert heart symbol>
BASIC: "[WA%111?;222X?+3333?" & Chr\$(3)
C: "[WA%111?;222X?+3333?\x03"
Hex: 5B 57 41 25 31 31 31 3F 3B 32 32 32 58 3F 2B 33 33 33 33 3F 03

Command rejected response (see next page for explanation):

ASCII: ●F0020♥
BASIC: Chr\$(2) & "F0020" & Chr\$(3)
C: "\x02F0020\x03"
Hex: 02 46 30 30 32 30 03

SOFTWARE CONTROLLED ENCODE RETURNED STATUS

Purpose: This is the response from a Software Controlled Encode command ([W]).

Response format: <STX> [CF] [EC] [TRK1S] [TRK2S] [TRK3S] <ETX>

Type	Field	Length	Comments
<STX>		1	ASCII 0x02
[CF]	Parameter	1	Coercivity flag. The actual encode coercivity used when the card was successfully encoded or status why the card was not encoded: 'H' (0x48) – Card encoded in HiCo 'L' (0x4C) – Card encoded in LoCo 'M' (0x4D) – Card removed before encoding completed 'F' (0x46) – Unable to encode card, see [TRKnS] below for reason 'S' (0x53) – If unit is in secure mode but the read hasn't been done yet, then this status is returned, all other parameters will be set to '0'
[EC]	Parameter	1	Encode count or bad encode data. Number of encode passes (right-to-left swipes) needed to encode the card. Any count greater than 9 returns a value of '9' If [CF] = 'M', then [EC] will be set to '0'. Range: '0' (0x30) to '9' (0x39) If [CF] = 'F' and one or more tracks are missing a Start Sentinel, then [EC] will be set to 'B' (0x42) else it will be a zero '0' (0x30)
[TRK1S]	Parameter	1	Track 1 status [CF] = 'H' or 'L' (encode successful): '0' (0x30) Encode was successful '1' (0x31) No data was passed for this track (any data already on the card for this track was not changed) [CF] = 'F' (did not encode): '0' (0x30) Data for this track was ok. The problem was due to one of the other tracks '1' (0x31) No data was passed for this track (which is ok.) The problem was due to one of the other tracks '2' (0x32) The data for this track was invalid '3' (0x33) Valid data was supplied for this track but this track is disabled. '4' (0x33) Encode failed (i.e., The data read during encode verify did not match the supplied encode data) [CF] = 'M' (card removed before completion) '0' (0x30) If card removed prematurely, track status will be returned as a zero
[TRK2]	Parameter	1	Track 2 status See [TRK1S] for details
[TRK3]	Parameter	1	Track 3 status See [TRK1S] for details
<ETX>	Response Terminator	1	0x03

SOFTWARE CONTROLLED READ COMMAND

Purpose: To begin a read process while in the Software Controlled Read Mode. The messages [MSG1] and [MSG2] will be displayed if either are present (if one is missing, that line will be blank). If neither are present (i.e. “[R<ETX>”) then the standard read messages will be displayed.

Command Format: [R [MSG1] <FS> [MSG2] <ETX>

Type	Field	Length	Comments
[Command prefix	1	ASCII 0x5B
R	Command	1	case insensitive, use 'R' (0x52) or 'r' (0x62)
[MSG1]	Parameter	0 to 40	(optional) Display message for the top line
<FS>	Separator	1	(optional) needed if [MSG1] less than 40 characters or is missing
[MSG2]	Parameter	0 to 40	(optional) Display message for the bottom line
<ETX>	Command terminator	1	0x03

Response Format: The encoder will acknowledge receipt of the software read command as follows:

<STX><ACK><ETX>

SET / RETRIEVE DSN

Purpose: To set or retrieve the Device Serial Number.

Command Format: [U [=] [DSN] <ETX>

Type	Field	Length	Comments
[Command prefix	1	ASCII 0x5B
U	Command	1	case insensitive, use 'U' (0x55) or 'u' (0x75)
[=]	Parameter	1	0x3D (optional) If present, current DSN is returned (see response below)
[DSN]	Parameter	16	(optional) The DSN to set. Range: space (0x20) to tilde (0x7E)
<ETX >	Command terminator	1	0x03 (optional) – must be present if [DSN] supplied

RESPONSE FORMAT:

If [=] passed in command (i.e. “[U=]”) then response will be:

<STX> U [DSN] <ETX>

RESPONSE EXAMPLE:

DSN of “MAGTEK-123456789” returned.

ASCII: ● UMAGTEK-123456789♥
Basic: Chr\$(2)& ”UMAGTEK-123456789” & Chr\$(3)
C: “\x2UMAGTEK-123456789\x3”
Hex: 02 55 4D 41 47 54 45 4B 2D 31 32 33 34 35 36 37 38 39 03

SOFTWARE ENCODE MESSAGE

Purpose: This command replaces the insert card message during an encoder operation.

Command format: [N [MSG] <ETX>

Type	Field	Length	Comments
[Command prefix	1	ASCII 0x5B
N	Command	1	case insensitive, use 'N' (0x4E) or 'n' (0x6E)
[MSG]	Parameter	0 to 40	(optional) Message for the top line, ASCII values 0x20 (space) to 0x7E (~)
<ETX >	Command Terminator	1	0x03

Example: Change the encode message to “Test message”:

Command:

ASCII: [NTest message♥

BASIC: "[NTest message" & Chr\$(3)

C: "[NTest message\x03"

Hex: 5B 4E 54 65 73 74 20 6D 65 73 73 61 67 65 03

Command accepted response:

ASCII: ☺ ▲ ♥

BASIC: Chr\$(2) & Chr\$(6) & Chr\$(3)

C: "\x02\x06\x03"

Hex: 02 06 03

SECTION 6. 4777 EMULATION MODE

This section contains information for the 4777 Emulation Mode.

INSTALLATION OF 4777 EMULATION MODE

The following equipment is required for installing the 4447 Emulation:

- Model MT-95 RS-232 HiCo Encoder/Reader P/N 31010020
- Power Cord P/N 71100001
- HiCo and LoCo test cards (1 each)
- Cable P/N 21015846 (MT-95 to IBM 4778 PIN-Pad)

Proceed as follows:

1. Disconnect the system Y-cable from the 4777. Do not disconnect the Y-cable from the IBM 4778 PIN-Pad.
2. Connect MagTek cable 21015846 to the rear panel of the MT-95, as shown in Figure 2-1.
3. Connect the open end of the Y-cable to the open end of the MagTek cable. The default parameters are automatically configured.
4. Plug the female end of the power cord into the rear panel of the encoder marked "POWER". Plug the other end into a power source.
5. Press "I" on the switch marked "ON".

The MT-95 4777 Emulation mode will be preset at the MagTek factory. If the encode energy needs to be modified or the customer's idle message needs to be changed, follow the instructions below.

MT-95 SETUP FOR ENCODE ENERGY

1. Turn off power switch on MT-95.
2. Disconnect the communication cable.
3. Attach an AT-style keyboard.
4. Turn on the power switch.

The following will appear briefly on the LCD:

Please wait during system self test

Then the following will appear:

MagTek MT-95 P/N: 30060819 Rev:J07
S)etup

5. Select **Setup** from the menu, and the following will appear:

Select option to change Esc=exit
I)dle Display E)ncode Energy C)ard Time

6. From the option menu, select **E**ncode to specify the encode energy level (**H**iCo, **L**oCo, or **A**uto detection). Press **Enter** when done.
7. Turn the power off.
8. Disconnect the keyboard.
9. Connect the communication cable.

MODIFYING IDLE MESSAGE ON MT-95

The 2-line idle message, i.e., the message that is shown when no command has been issued, can be specified by the user. Up to 40 characters can be placed on each line. Follow the directions below to change the idle message.

1. Turn off power switch on MT-95.
2. Disconnect the communication cable.
3. Attach an AT-style keyboard.
4. Turn on the power switch.

The following will appear briefly on the LCD:

Please wait during system self test

Then the following will appear:

MagTek MT-95 P/N: 30060819 Rev:J07
S)etup

5. Select **Setup** from the menu, and the following will appear:

Select option to change Esc=exit
I)dle Display E)ncode Energy C)ard Time

6. Select the **I**dle Display messages and the following will appear:

Select line to edit Esc=done
Press T)op line B)ottom line

7. The top line and bottom lines can be independently modified. Select **T** for the top line or **B** for the bottom line.
8. Type any message you wish to appear when the unit is idle. The **Insert** key can be used to toggle between insert and overstrike modes. The message can be left-, right-, or center-justified by pressing **F3** on the keyboard. The other editing keys, e.g., home and arrows, can be used to move the cursor. When the message is satisfactory, press **Enter**. Edit the other line in the same manner.
9. The two-line message will be saved in battery-backed RAM until this process is used to modify the message.
10. Press **Esc** twice to return to the main menu.
11. Turn the power off.
12. Disconnect the keyboard.
13. Connect the communication cable.
14. Turn the power on.

MODIFYING ENCODE TIMEOUT

1. Turn off power switch on MT-95.
2. Disconnect the communication cable.
3. Attach an AT-style keyboard.
4. Turn on the power switch.

The following will appear briefly on the LCD:

Please wait during system self test

Then the following will appear:

MagTek MT-95 P/N: 30060819 Rev:J07
S)etup

5. Select **S**etup from the menu and the following will appear:

MT-95 RS-232 HiCo/LoCo Encoder/Reader

Select option to change Esc=exit
I)dle Display E)ncode Energy C)ard Time

6. Select **Card Time** and the following will appear:

Type in Encode Timeout: [Ins] Enter=done
030 Seconds (Max=255, 0=Disable Timeout)

7. Specify the number of seconds that will be allowed before the encode operation is automatically terminated. Press **Enter** when done.
8. Press **Esc**.
9. Turn the power off.
10. Disconnect the keyboard.
11. Connect the communication cable.
12. Turn the power on.

MT-95 USER MESSAGES

Here is a full set of conditions and messages (where <Idle Top> and <Idle Bottom> are the user-defined idle messages). Messages are centered in the line and other punctuation may be included:

Idle (with or without a card):

<Idle Top>
<Idle Bottom>

Read command issued, no card:

<Idle Top>
Insert card for reading

Read command issued and card in slot:

<Idle Top>
Slide card right when ready

After read (for at least 1 second):

ISO format data read on track 1 2
Waiting for Host Response

After read (and host has responded, even if card still in slot):

<Idle Top>
<Idle Bottom>

Encode command issued, no card:

Encoding data on track 1 2
Insert card for encoding (Auto)

Encode command issued and card in slot:

Encoding data on track 1 2
Slide card left when ready

After encode (for at least 4 seconds):

**Card encoded correctly
Follow PC screen instructions**

After encode (and host has responded, even if card still in slot):

**<Idle Top>
<Idle Bottom>**

After encode command issued with card at right side but card not swiped within 20 seconds:

**Timeout waiting for card to be swiped
Remove the card**

(In this case, the operation can continue when the card is inserted back into the slot.)

After a bad encode (continues forever until good encode or card removed):

**Did not encode properly. Try again.
Slide card right when ready.**

After an attempt to encode on a HiCo card when unit is set to Auto:

**This may be a HiCo card. Try again.
Slide the card right when ready.**

APPENDIX B. TESTS

These test show the control characters as <xxx> but they are sent as their ASCII value, e.g., <STX> as the single character with a value of 2. On a terminal program, this can be achieved by pressing Ctrl and the B keys. In BASIC, this can be achieved by sending Chr\$(2). In C, it would be 0x02.

Control	Ctrl Key +	BASIC	C	Shows as:
<ACK>	F	Chr\$(6)	0x06	␣
<ETX>	C	Chr\$(3)	0x03	␣
<FS>	\	Chr\$(28))	0x1 C	L
<NAK>	U	Chr\$(21))	0x15	\$
<STX>	B	Chr\$(2)	0x02	␣

SOFTWARE MODE

Set Software Mode On:

(send) /M1
(recv) <STX><ACK><ETX>

SET IDLE MESSAGES

Set the top line of the Idle Message to “First National Bank of Anywhere”

(send) [I First National Bank of Anywhere<ETX>
(recv) <STX><ACK><ETX>

The top line of the display should show “First National Bank of Anywhere”, left-justified.

Set the bottom line of the Idle Message to “Waiting for commands”

(send) [JWaiting for commands<ETX>
(recv) <STX><ACK><ETX>

The bottom line of the display should show “Waiting for commands”, left-justified.

SOFTWARE CONTROLLED READ

Testing that the software read idle mode is not affected by the control line or by a card being inserted:

1. Disconnect the signal cable (or turn DTR off and on).
 2. Insert and remove a card, anywhere in the slot
- In both cases, the display should still show the Idle message.

MT-95 RS-232 HiCo/LoCo Encoder/Reader

Test read without display change. Without a card in the slot, send the command:

(send) **[R<ETX>**
(recv) **<STX><ACK><ETX>**

The display should not change. Insert a card. The display should indicate which direction to swipe the card. When the swipe is done, the data will be returned.

(recv) **<STX>%111111?;2222222222?+3333333333333333?<ETX>**

Test read with embedded message:

(send) **[R Please insert<FS>and swipe your card<ETX>**
(recv) **<STX><ACK><ETX>**

The top line should show “Please insert” and the bottom line should show “and swipe your card” until a card is inserted. At this time, the display should tell you which direction to swipe the card.

SOFTWARE CONTROLLED ENCODE

Testing the encode command without specifying the coercivity.

(send)/**A** (set default coercivity to Auto)
(recv)**<STX><ACK><ETX>** (change to coercivity accepted)
(send)[**W%11111?;22222222?<ETX>**

Display should show “Insert card for encoding (Auto)” on the bottom line. Swipe the card.

(recv)**<STX>H1000<ETX>** (after encoding HiCo card)

or

(recv)**<STX>L1000<ETX>** (after encoding LoCo card)

Testing the encode command with specified coercivity.

(send)[**WH%11111?;22222222?<ETX>**

Display should show “Insert card for encoding (HiCo)” on the bottom line. Swipe the card.

(recv)**<STX>H1000<ETX>** (after encoding)

INDEX

/
/A..... 31, 56
/B..... 32
/C..... 32
/Dn..... 32
/En..... 32
/H..... 31
/K..... 32
/L..... 31
/M..... 34
/M1..... 37, 55
/Mn..... 31
/N..... 31, 34
/P..... 32
/Q..... 32
/S..... 31
/T..... 32
/V..... 32
/X..... 32

[
[I..... 31, 37, 55
[J..... 31, 38, 55
[N..... 31, 45
[O..... 31, 39
[R..... 31, 34, 43, 56
[U..... 31, 44
[W..... 31, 40, 42, 56
[WA..... 41
[WH..... 56

4
4777 Emulation Installation..... 47

A
Alternate encode ([W)..... 31
Auto mode..... 11, 16, 22, 27
Automatic Selection Mode 31

B
Baud rate..... 9, 10, 32
Bottom Line 38

C
Cable 47, 53
Cable, PC 2, 5
Card Copying 19
Card Encoding 20, 27
Card orientation 4
Card reading..... 15
Card Reading 18, 27
Card Time 50
Card timeout..... 12
Change Configuration..... 32
Change Display 31
Character sets 35
Coercivity..... 1, 10, 31
Communication Port 6
Connection, encoder to PC 7
Copy cards 19
Copying..... 19
CTS 53

D
Data Bits 10
Default parameters 10
Device Serial Number..... 44
Dimensions 3
Disable a track (/Dn)..... 32
Display Immediate 39
Display immediate ([O) 31
DSN Set / Retrieve..... 44
DSR..... 53
DTR..... 27, 53

E
Enable a track (/En) 32
Encode Command..... 30, 40
Encode Energy 47

Encode formats, online 33
Encode Mode 11, 31
Encode Timeout 49
Encoded message format 29
Encoder parts 4
Encoding 15, 20
End of Text (ETX) 30
End Sentinel 30, 35
Error message..... 12

F

Features
 4777 Emulation Mode..... 1
 Standard Mode 1
Features and Specifications 1–4
Field Separator 25, 35
Fixed Format Encoding..... 15, 22
Format Card, Create..... 24
Free Format Encoding..... 15, 20

H

Hardware installation 5
HiCo..... 1, 10, 16, 31
Hidden commands 12
Humidity 3

I

Idle Message 31, 37, 48
Installation and Setup..... 5–13
Installation of 4777 Emulation 47
IntelliCAT..... 1
IntelliCoder 1, 2, 5
IntelliCoder Setup..... 13
Interface 3
ISO standards 1

K

Keyboard..... 2, 5, 6
Keyboard can be used only for setup (/X) 32

L

LCD intensity adjustment 1, 8
LCD, Liquid Crystal Display 1
LoCo 1, 3, 10, 16, 31

M

Magnetic Read 3
Modifying Encode Timeout..... 49
Modifying Idle Message 48
MT-80 manual 2, 27
MT-80 program..... 2, 27

N

Normal Mode 11, 31, 34

O

Online Card Operation..... 27
Online commands 31
Online encode formats 33
Online Modes..... 34
Online Programming..... 28–37

P

Parity, select..... 10
Parts Required
 Standard MT-95 5
PC encoded examples 30
Pin Lists 53
Power 3, 6
PROM number and version 8

R

Read/encode in standalone (/K)..... 32
Read-after-write status 13
Reading 18
Rear panel 6
Request card position (/P)..... 32
Request current track setup (/T)..... 32
Request MT-95 configuration (/C) 32
Request version (/V) 32
Requirements 2
 4777 Emulation Mode..... 2
 4777 Emulation MT-95..... 5
 Standard Mode 2
Revision number, EPROM 8
RTS 53
RXD 53

S

Secure Mode	11, 30, 31, 35
Send to the MT-95 to abort (/Q)	32
Set / Retrieve DSN.....	44
Set Idle Messages.....	55
Set/Retrieve Device Serial Number ([U]) ..	31
Setup	8, 13
Software Controlled Encode.....	42, 56
Software Controlled Mode.....	31, 34
Software Controlled Read.....	31, 43, 55
Software Encode Message	31, 45
Software Mode.....	55
Sound the buzzer (/B)	32
Specifications.....	3
Standalone Operation.....	15–26
Start of Text (STX)	29
Start Sentinel.....	29, 35

Stop bits, select	10
-------------------------	----

T

Temperature	3
Tests	55
Timeout value	12
Top and Bottom Line	37
Track Character Sets.....	35
Track data	30
Tracks.....	10
TXD	53

U

User Messages	50
---------------------	----

V

Version.....	32
--------------	----

