

# ***IMAGESAFE SCANNER***

## **MICR READER AND DUAL-SIDED CHECK SCANNER INSTALLATION AND OPERATION MANUAL**

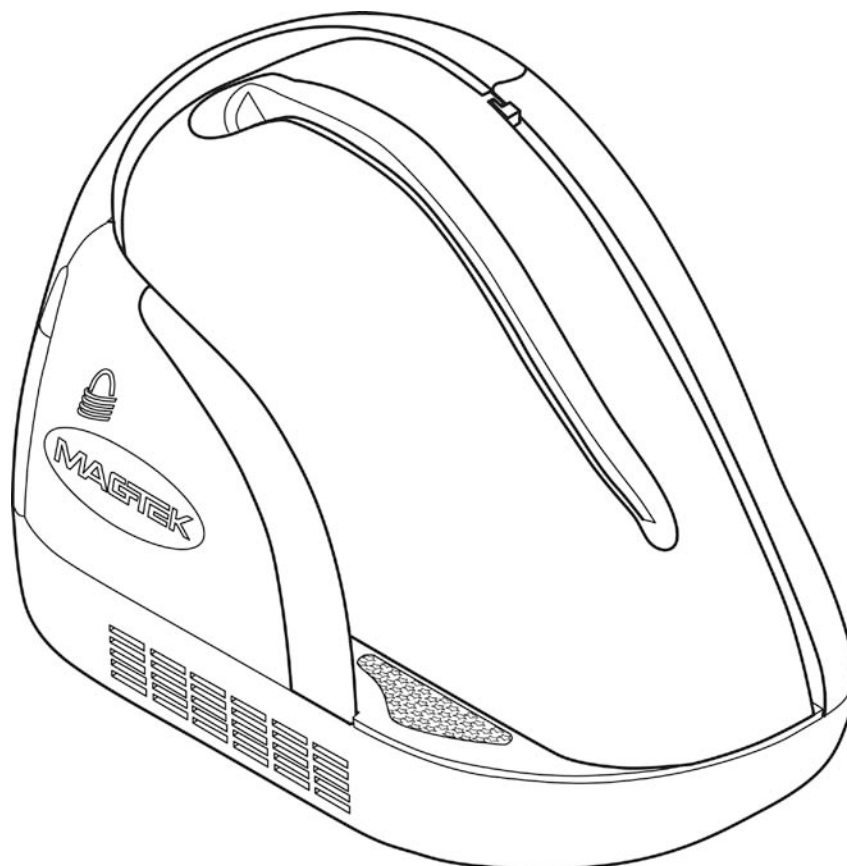

**Manual Part Number: 99875472-3**

**MARCH 2010**

**MAGTEK<sup>®</sup>**  
SECURITY FROM THE INSIDE

**REGISTERED TO ISO 9001:2008**

1710 Apollo Court  
Seal Beach, CA 90740  
Phone: (562) 546-6400  
Tech Support: (888) 624-8350  
[www.magtek.com](http://www.magtek.com)

Copyright© 2007 - 2010  
MagTek®, Inc.  
Printed in the United States of America

Information in this document is subject to change without notice. No part of this document may be reproduced or transmitted in any form or by any means, electronic or mechanical, for any purpose, without the express written permission of MagTek, Inc.

MagTek is a registered trademark of MagTek, Inc.

ImageSafe™ is a trademark of MagTek, Inc.

MagnePrint® is a trademark of MagTek, Inc.

## REVISIONS

Rev Number	Date	Notes
1.01	22 February 2010	Initial Release
2.01	22 February 2010	Product Name Change
3.01	10 March 2010	Requirements p.5 updated; Image added section 2

## LIMITED WARRANTY

MagTek warrants that the products sold pursuant to this Agreement will perform in accordance with MagTek's published specifications. This warranty shall be provided only for a period of one year from the date of the shipment of the product from MagTek (the "Warranty Period"). This warranty shall apply only to the "Buyer" (the original purchaser, unless that entity resells the product as authorized by MagTek, in which event this warranty shall apply only to the first repurchaser).

During the Warranty Period, should this product fail to conform to MagTek's specifications, MagTek will, at its option, repair or replace this product at no additional charge except as set forth below. Repair parts and replacement products will be furnished on an exchange basis and will be either reconditioned or new. All replaced parts and products become the property of MagTek. This limited warranty does not include service to repair damage to the product resulting from accident, disaster, unreasonable use, misuse, abuse, negligence, or modification of the product not authorized by MagTek. MagTek reserves the right to examine the alleged defective goods to determine whether the warranty is applicable.

Without limiting the generality of the foregoing, MagTek specifically disclaims any liability or warranty for goods resold in other than MagTek's original packages, and for goods modified, altered, or treated without authorization by MagTek.

Service may be obtained by delivering the product during the warranty period to MagTek (1710 Apollo Court, Seal Beach, CA 90740). If this product is delivered by mail or by an equivalent shipping carrier, the customer agrees to insure the product or assume the risk of loss or damage in transit, to prepay shipping charges to the warranty service location, and to use the original shipping container or equivalent. MagTek will return the product, prepaid, via a three (3) day shipping service. A Return Material Authorization ("RMA") number must accompany all returns. Buyers may obtain an RMA number by contacting Technical Support at (888) 624-8350.

**EACH BUYER UNDERSTANDS THAT THIS MAGTEK PRODUCT IS OFFERED AS IS. MAGTEK MAKES NO OTHER WARRANTY, EXPRESS OR IMPLIED, AND MAGTEK DISCLAIMS ANY WARRANTY OF ANY OTHER KIND, INCLUDING ANY WARRANTY OF MERCHANTABILITY OR FITNESS FOR A PARTICULAR PURPOSE.**

IF THIS PRODUCT DOES NOT CONFORM TO MAGTEK'S SPECIFICATIONS, THE SOLE REMEDY SHALL BE REPAIR OR REPLACEMENT AS PROVIDED ABOVE. MAGTEK'S LIABILITY, IF ANY, SHALL IN NO EVENT EXCEED THE TOTAL AMOUNT PAID TO MAGTEK UNDER THIS AGREEMENT. IN NO EVENT WILL MAGTEK BE LIABLE TO THE BUYER FOR ANY DAMAGES, INCLUDING ANY LOST PROFITS, LOST SAVINGS, OR OTHER INCIDENTAL OR CONSEQUENTIAL DAMAGES ARISING OUT OF THE USE OF, OR INABILITY TO USE, SUCH PRODUCT, EVEN IF MAGTEK HAS BEEN ADVISED OF THE POSSIBILITY OF SUCH DAMAGES, OR FOR ANY CLAIM BY ANY OTHER PARTY.

### **LIMITATION ON LIABILITY**

EXCEPT AS PROVIDED IN THE SECTIONS RELATING TO MAGTEK'S LIMITED WARRANTY, MAGTEK'S LIABILITY UNDER THIS AGREEMENT IS LIMITED TO THE CONTRACT PRICE OF THIS PRODUCT.

MAGTEK MAKES NO OTHER WARRANTIES WITH RESPECT TO THE PRODUCT, EXPRESSED OR IMPLIED, EXCEPT AS MAY BE STATED IN THIS AGREEMENT, AND MAGTEK DISCLAIMS ANY IMPLIED WARRANTY, INCLUDING WITHOUT LIMITATION ANY IMPLIED WARRANTY OF MERCHANTABILITY OR FITNESS FOR A PARTICULAR PURPOSE.

MAGTEK SHALL NOT BE LIABLE FOR CONTINGENT, INCIDENTAL, OR CONSEQUENTIAL DAMAGES TO PERSONS OR PROPERTY. MAGTEK FURTHER LIMITS ITS LIABILITY OF ANY KIND WITH RESPECT TO THE PRODUCT, INCLUDING ANY NEGLIGENCE ON ITS PART, TO THE CONTRACT PRICE FOR THE GOODS.

MAGTEK'S SOLE LIABILITY AND BUYER'S EXCLUSIVE REMEDIES ARE STATED IN THIS SECTION AND IN THE SECTION RELATING TO MAGTEK'S LIMITED WARRANTY.

### **FCC WARNING STATEMENT**

This equipment has been tested and was found to comply with the limits for a Class B digital device pursuant to Part 15 of FCC Rules. These limits are designed to provide reasonable protection against harmful interference when the equipment is operated in a residential environment. This equipment generates, uses, and can radiate radio frequency energy and, if not installed and used in accordance with the instruction manual, may cause harmful interference with radio communications. However, there is no guarantee that interference will not occur in a particular installation.

### **FCC COMPLIANCE STATEMENT**

This device complies with Part 15 of the FCC Rules. Operation of this device is subject to the following two conditions: (1) this device may not cause harmful interference, and (2) this device must accept any interference received, including interference that may cause undesired operation.

### **CANADIAN DOC STATEMENT**

This digital apparatus does not exceed the Class B limits for radio noise from digital apparatus set out in the Radio Interference Regulations of the Canadian Department of Communications.

Le présent appareil numérique n'émet pas de bruits radioélectriques dépassant les limites applicables aux appareils numériques de la classe B prescrites dans le Règlement sur le brouillage radioélectrique édicté par le ministère des Communications du Canada.

This Class B digital apparatus complies with Canadian ICES-003.

Cet appareil numérique de la classe B est conforme à la norme NMB-003 du Canada.

### **CE STANDARDS**

Testing for compliance with CE requirements was performed by an independent laboratory. The unit under test was found compliant with standards established for Class B devices.

### **UL/CSA**

This product is recognized per Underwriter Laboratories and Canadian Underwriter Laboratories 1950.

### **RoHS STATEMENT**

When ordered as RoHS compliant, this product meets the Electrical and Electronic Equipment (EEE) Reduction of Hazardous Substances (RoHS) European Directive 2002/95/EC. The marking is clearly recognizable, either as written words like "Pb-free", "lead-free", or as another clear symbol (.

## SOFTWARE LICENSE AGREEMENT

IMPORTANT: YOU SHOULD CAREFULLY READ ALL THE TERMS, CONDITIONS AND RESTRICTIONS OF THIS LICENSE AGREEMENT BEFORE INSTALLING THE SOFTWARE PACKAGE. YOUR INSTALLATION OF THE SOFTWARE PACKAGE PRESUMES YOUR ACCEPTANCE OF THE TERMS, CONDITIONS, AND RESTRICTIONS CONTAINED IN THIS AGREEMENT. IF YOU DO NOT AGREE WITH THESE TERMS, CONDITIONS, AND RESTRICTIONS, PROMPTLY RETURN THE SOFTWARE PACKAGE AND ASSOCIATED DOCUMENTATION TO THE ABOVE ADDRESS, ATTENTION: CUSTOMER SUPPORT.

### TERMS, CONDITIONS, AND RESTRICTIONS

MagTek, Incorporated (the "Licensor") owns and has the right to distribute the described software and documentation, collectively referred to as the "Software".

**LICENSE:** Licensor grants you (the "Licensee") the right to use the Software in conjunction with MagTek products. LICENSEE MAY NOT COPY, MODIFY, OR TRANSFER THE SOFTWARE IN WHOLE OR IN PART EXCEPT AS EXPRESSLY PROVIDED IN THIS AGREEMENT. Licensee may not decompile, disassemble, or in any other manner attempt to reverse engineer the Software. Licensee shall not tamper with, bypass, or alter any security features of the software or attempt to do so.

**TRANSFER:** Licensee may not transfer the Software or license to the Software to another party without the prior written authorization of the Licensor. If Licensee transfers the Software without authorization, all rights granted under this Agreement are automatically terminated.

**COPYRIGHT:** The Software is copyrighted. Licensee may not copy the Software except for archival purposes or to load for execution purposes. All other copies of the Software are in violation of this Agreement.

**TERM:** This Agreement is in effect as long as Licensee continues the use of the Software. The Licensor also reserves the right to terminate this Agreement if Licensee fails to comply with any of the terms, conditions, or restrictions contained herein. Should Licensor terminate this Agreement due to Licensee's failure to comply, Licensee agrees to return the Software to Licensor. Receipt of returned Software by the Licensor shall mark the termination.

**LIMITED WARRANTY:** Licensor warrants to the Licensee that the disk(s) or other media on which the Software is recorded are free from defects in material or workmanship under normal use.

**THE SOFTWARE IS PROVIDED AS IS. LICENSOR MAKES NO OTHER WARRANTY OF ANY KIND, EITHER EXPRESS OR IMPLIED, INCLUDING, BUT NOT LIMITED TO, THE IMPLIED WARRANTIES OF MERCHANTABILITY AND FITNESS FOR A PARTICULAR PURPOSE.**

Because of the diversity of conditions and PC hardware under which the Software may be used, Licensor does not warrant that the Software will meet Licensee specifications or that the operation of the Software will be uninterrupted or free of errors.

IN NO EVENT WILL LICENSOR BE LIABLE FOR ANY DAMAGES, INCLUDING ANY LOST PROFITS, LOST SAVINGS, OR OTHER INCIDENTAL OR CONSEQUENTIAL DAMAGES ARISING OUT OF THE USE, OR INABILITY TO USE, THE SOFTWARE. Licensee's sole remedy in the event of a defect in material or workmanship is expressly limited to replacement of the Software disk(s) if applicable.

**GOVERNING LAW:** If any provision of this Agreement is found to be unlawful, void, or unenforceable, that provision shall be removed from consideration under this Agreement and will not affect the enforceability of any of the remaining provisions. This Agreement shall be governed by the laws of the State of California and shall inure to the benefit of MagTek, Incorporated, its successors or assigns.

**ACKNOWLEDGMENT:** LICENSEE ACKNOWLEDGES THAT HE HAS READ THIS AGREEMENT, UNDERSTANDS ALL OF ITS TERMS, CONDITIONS, AND RESTRICTIONS, AND AGREES TO BE BOUND BY THEM. LICENSEE ALSO AGREES THAT THIS AGREEMENT SUPERSEDES ANY AND ALL VERBAL AND WRITTEN COMMUNICATIONS BETWEEN LICENSOR AND LICENSEE OR THEIR ASSIGNS RELATING TO THE SUBJECT MATTER OF THIS AGREEMENT.

QUESTIONS REGARDING THIS AGREEMENT SHOULD BE ADDRESSED IN WRITING TO MAGTEK, INCORPORATED, ATTENTION: CUSTOMER SUPPORT, AT THE ABOVE ADDRESS, OR E-MAILED TO [support@magtek.com](mailto:support@magtek.com).



# TABLE OF CONTENTS

<b>SECTION 1. OVERVIEW .....</b>	<b>1</b>
FEATURES.....	2
ACCESSORIES.....	2
SPECIFICATIONS.....	3
<b>SECTION 2. INSTALLATION .....</b>	<b>5</b>
REQUIREMENTS.....	5
CABLING PROCEDURE.....	6
<b>SECTION 3. OPERATION .....</b>	<b>9</b>
CHECK READING PROCEDURE.....	9
CARD READING PROCEDURE .....	10
LED INDICATORS.....	11
CLEANING .....	11
Opening the Unit.....	12
Cleaning Check Path and Scan Bars .....	13
Closing the Unit .....	17
<b>SECTION 4. TROUBLESHOOTING GUIDE.....</b>	<b>19</b>
REQUIREMENTS.....	19
SET-UP.....	19
TROUBLESHOOTING.....	19
<b>APPENDIX A. CHECK READING .....</b>	<b>25</b>
E13-B CHARACTER SET .....	25
CMC-7 CHARACTER SET .....	25
SI   SII   SIII   SIV   S5.....	25
CHECK LAYOUTS .....	26
MICR FIELDS .....	27
1-Transit Field.....	27
2-On-Us Field .....	28
3-Amount Field .....	28
4-Auxiliary On-Us Field .....	28
<b>APPENDIX B. DEMO SOFTWARE AND USB DRIVERS .....</b>	<b>29</b>

## FIGURES

Figure 1-1. ImageSafe Scanner and Dual-sided Scanner with MagneSafe Secure Reader.....	1
Figure 2-1. ImageSafe Component Identification .....	5
Figure 2-2. ImageSafe Cabling (U.S. Version) .....	6
Figure 2-3. ImageSafe Cabling (International Version) .....	7
Figure 2-4. ImageSafe Connections .....	7
Figure 2-5. ImageSafe Cable Clip.....	8
Figure 3-1. Check Orientation - Insertion.....	9
Figure 3-2. MagneSafe Reader Swipe.....	10
Figure 3-3. Opening the Unit.....	12
Figure 3-4. Cleaning Check Path and Scan Bars .....	13
Figure 3-5. Activating the Cleaning Swab.....	14
Figure 3-6. Cleaning the First Scan Bar.....	15
Figure 3-7. Cleaning the Second Scan Bar .....	16
Figure 3-8. Closing the Unit .....	17
Figure 4-1. Sensor Location.....	21
Figure A-1. Personal Checks .....	26
Figure A-2. Business Checks.....	27

## TABLES

Table 1-1 ImageSafe Accessories .....	2
Table 1-2. Specifications.....	3
Table 3-1. LED indicators.....	11
Table A-1. CMC-7 Nonnumeric Characters .....	26

## SECTION 1. OVERVIEW

The ImageSafe™ Scanner is a single-feed MICR (Magnetic Ink Character Recognition) reader and a dual-sided check scanner. In a single pass, the ImageSafe Scanner reads the MICR characters at the bottom of a check and produces a digitized image of the entire check (front and back). The characters and the image are then transmitted to a host device which is typically a PC.

The ImageSafe Scanner also offers an integrated MagneSafe™ secure card reader to secure card based payment transactions by encrypting the encoded card holder date on debit, credit and gift cards. The MagneSafe reader can be used with a magstripe card for 2-factor authentication during web based financial transactions. The MagneSafe reader will auto-discriminate between different card formats such as: ISO (International Standards Organization) or AAMVA (American Association of Motor Vehicle Administrators).

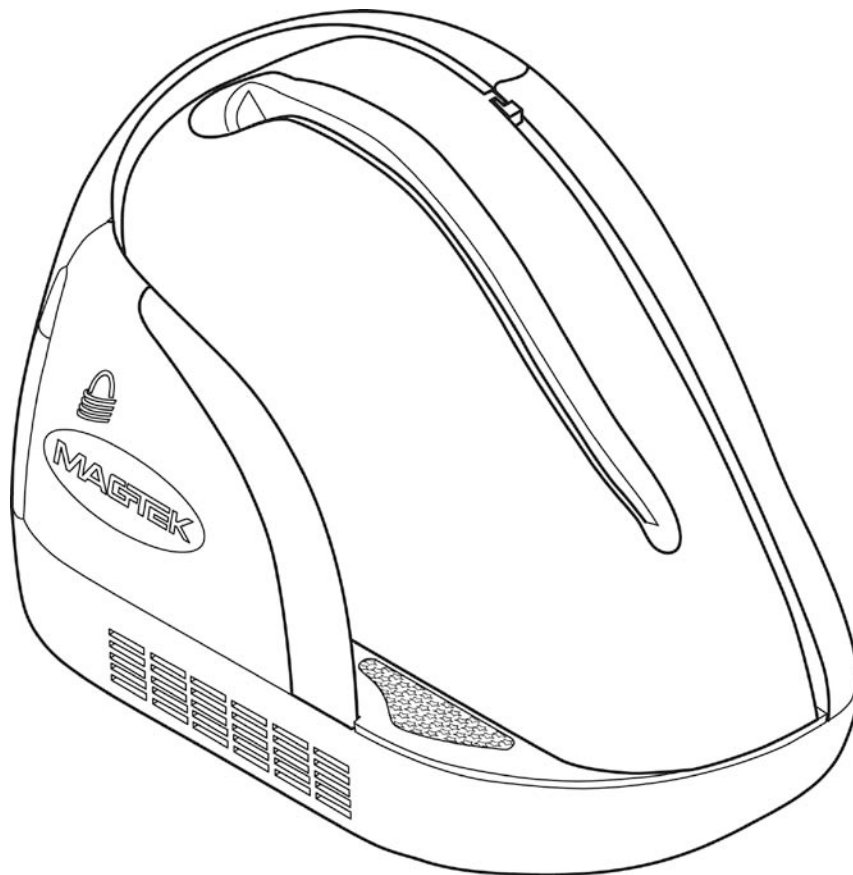

**Figure 1-1. ImageSafe Scanner and Dual-sided Scanner with MagneSafe Secure Reader**

## FEATURES

The ImageSafe Scanner is equipped with the following features:

- Single check feed
- MICR reader with support for E13B and CMC7 fonts
- Automatic parsing of MICR fields: transit, account, etc
- Extensive list of formats to transmit MICR data
- Dual-sided scanning which allows complete images of both sides of a check to be captured
- Image rendition: black/white and grayscale
- Image resolution: 200 dpi
- Image files: TIFF 6.0, JFIF with EXIF tags, BMP
- Image compression: CCITT G4 or JPEG
- Ability to capture up to four images per check
- SHA1 digital signature for image file authentication
- MagneSafe secure card reader
- LED indicator to provide device status
- Cover swings open for easy access to check path and scan bars with no tools required

## ACCESSORIES

The following is a list of available accessories for the ImageSafe Scanner:

Part Number	Description
22350300	USB 2.0 A-B BLK 6'
64300090	PWR SUPPLY-DESKTOP, 12VDC 1.5A, 120V (U.S. VERSION)
64300080	PWR SUPPLY-DESKTOP, 12VDC 1.5A, 240V (INT. VERSION)
96530028	SAMPLE CHECKS. PACK OF 5
97200033	CLEANING SWABS
22359069	DEMO SOFTWARE CD
22415101	CLIP-USB/PWR SUP CORDS

**Table 1-1. ImageSafe Accessories**

## SPECIFICATIONS

Table 1-2 lists the specifications for the ImageSafe Scanner.

**Table 1-2. Specifications**

<b>OPERATING</b>	
Reference Standards	ANSI X9.27
Power Input	12VDC, 1.5 Amp
Current (Operating Idle)	300 mA 1.5 A Max
MTBF	Electronics: 125,000 hours Check Read Head: 1,000,000 passes MSR Read head: 1,000,000 passes
Document Speed	10 ips
Document Size	4"x 9" Maximum 3"x 2.625" Minimum
Image Resolution	200 dpi
MICR fonts supported	E13-B CMC-7
Interface Options	USB 2.0 or USB 1.1
<b>MECHANICAL</b>	
Dimensions	Length 9.0", Width 3.9", Height 6.0"
Weight:	2.2 lbs.
Connector:	USB B
<b>ENVIRONMENTAL</b>	
Temperature	
Operating	0°C to 50°C (32°F to 122°F)
Storage	-30°C to 70°C (-22°F to 158°F)
Humidity	
Operating	10% to 90% non-condensing
Storage	Up to 100% non-condensing
Altitude	
Operating	0 -10,000 ft (0 - 3,048m)
Storage	0 - 50,000 ft (0 - 15240m)



## SECTION 2. INSTALLATION

Installation of the ImageSafe Scanner is described below figure 2-1 shows a cad being swiped through the MagneSafe card reader.

**Note:** Install the ImageSafe software before connecting the ImageSafe Scanner to a computer. Failure to perform this step will prevent the ImageSafe application from installing properly.

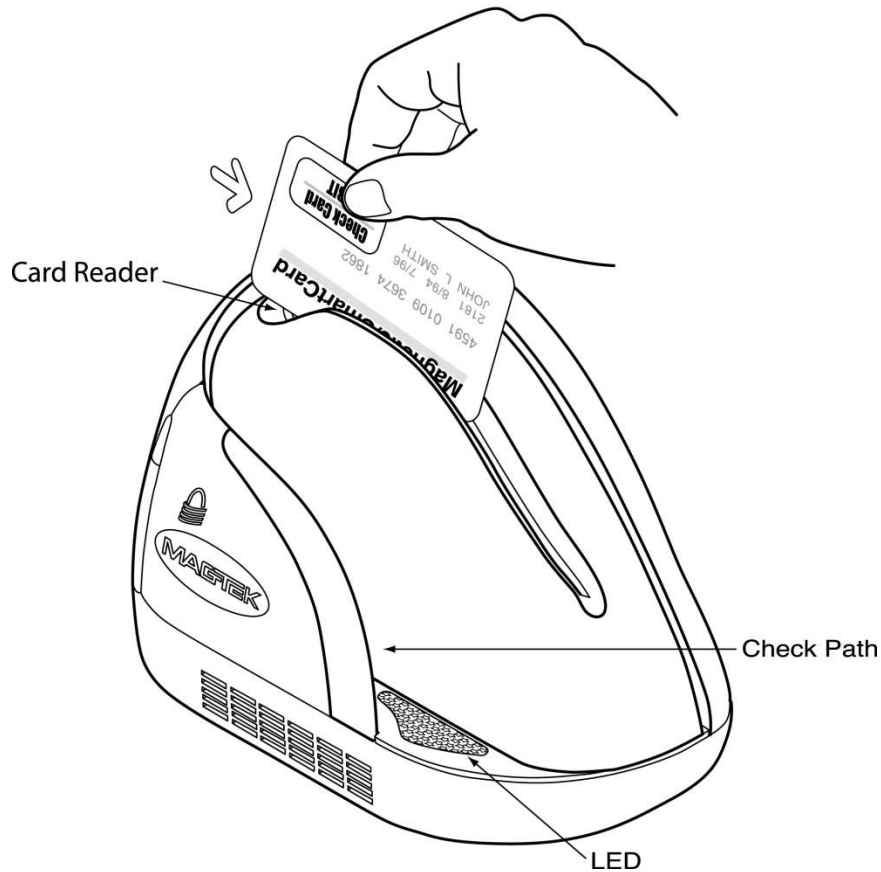

**Figure 2-1. ImageSafe Component Identification**

### REQUIREMENTS

The following items should be present in ImageSafe Scanner box and will be required for installation:

- ImageSafe Scanner
- Hi-Speed USB Cable
- Power Adapter
- Installation software CD (optional)

## CABLING PROCEDURE

To connect the ImageSafe Scanner to a local computer locate the power and USB cables contained in the box. Once the cables have been located perform the following steps:

1. Connect the USB plug to the ImageSafe Scanner as shown in Figures 2-2 and 2-4.
2. On the AC power adapter, connect the power plug to the device
3. On the AC power adapter, connect the plug to wall outlet
4. The LED indicator on the ImageSafe Scanner should turn on to a steady green. The LED indicator on the ImageSafe Scanner is located on the slot where the check is first inserted for reading (see figure 2.1). If the LED does not turn green refer to the LED indication section.

### *Caution*

*Do not place the ImageSafe Scanner within 6 inches of a computer monitor or power supply. These devices may cause undesirable interference with the check reading operation.*

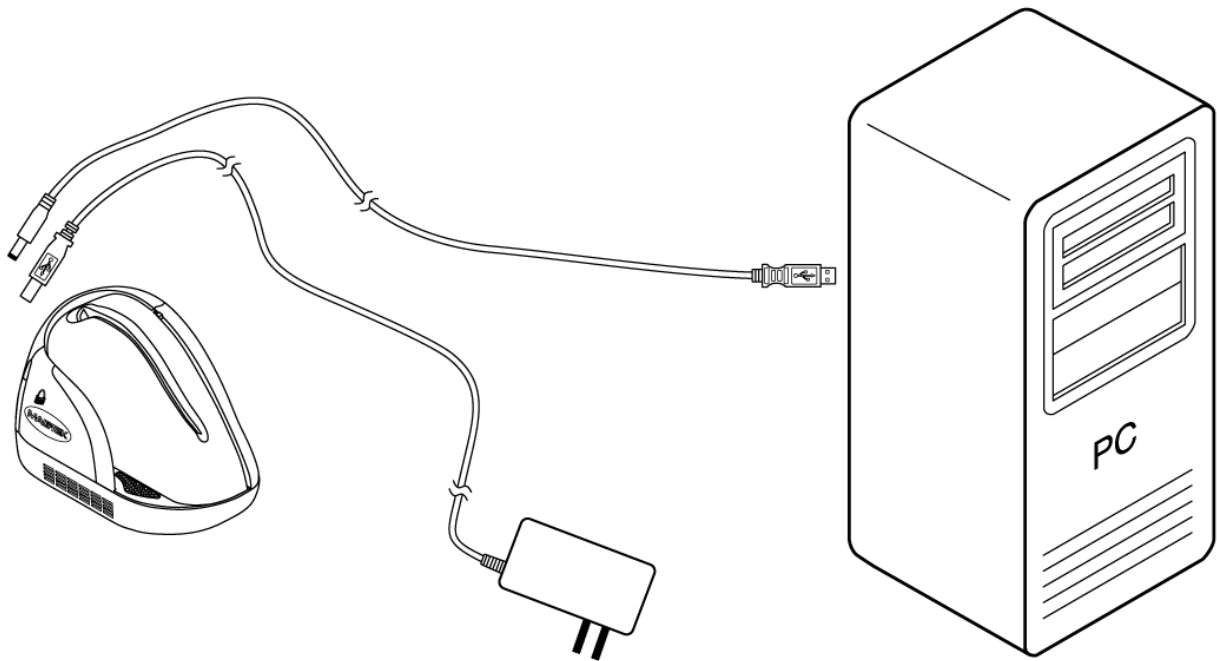

**Figure 2-2. ImageSafe Cabling (U.S. Version)**

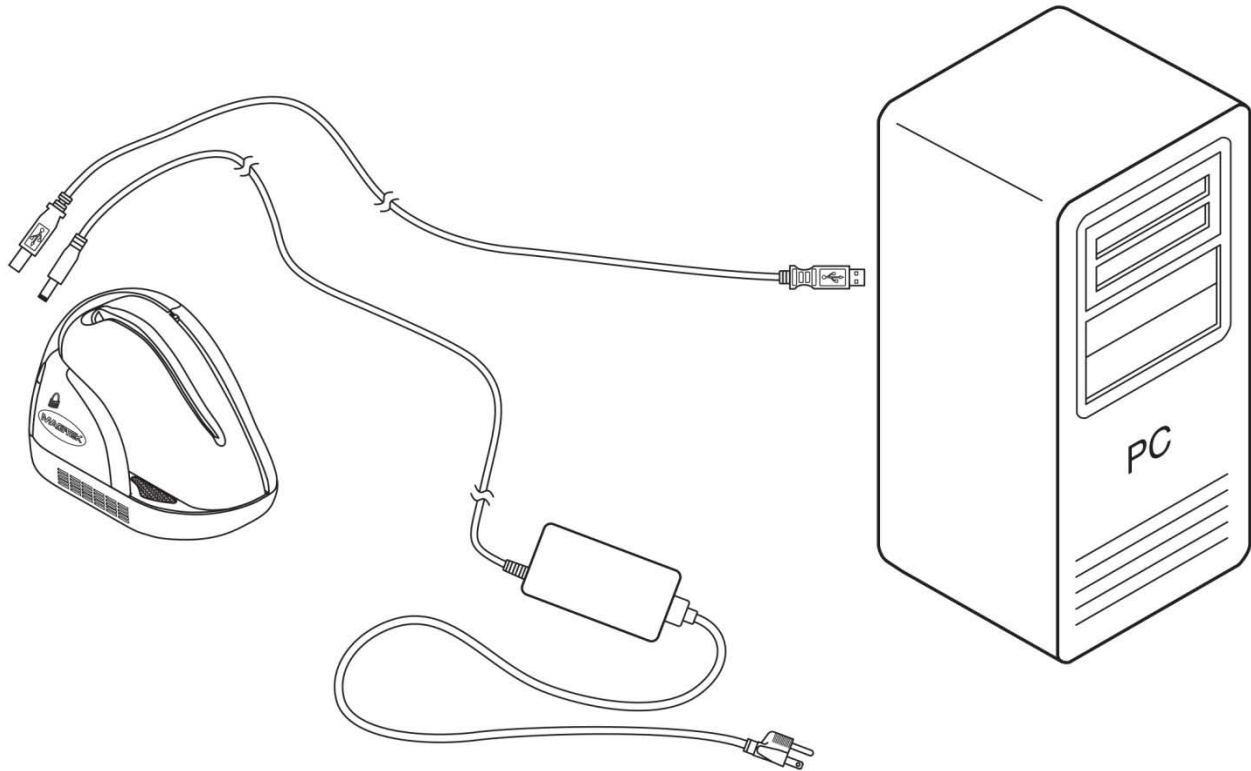

Figure 2-3. ImageSafe Cabling (International Version)

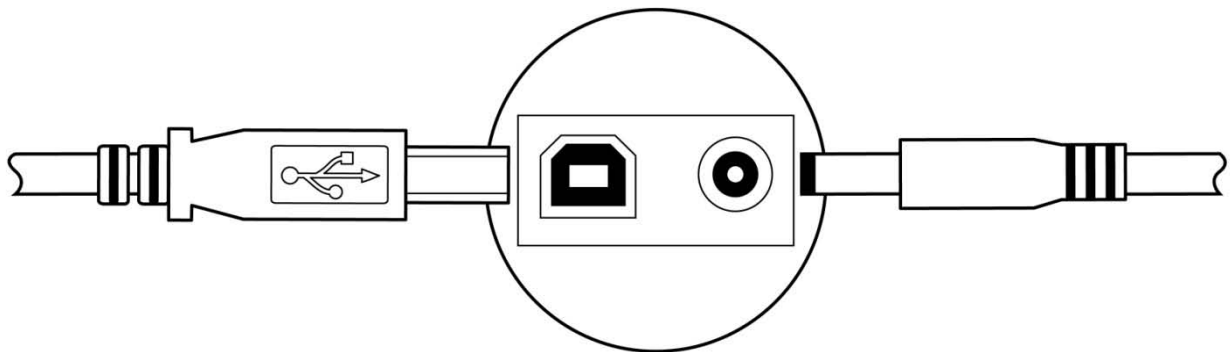
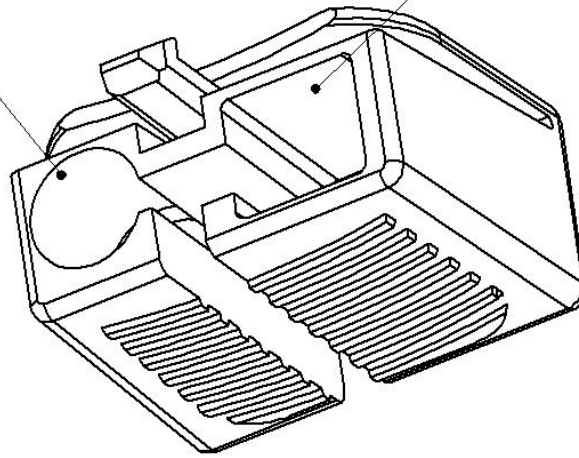

Figure 2-4. ImageSafe Connections

**Note:** An optional strain relief clip can be installed to securely attach the USB and power supply cable to the ImageSafe chassis. To install the clip insert the cables into the retaining clip and then plug the clip with cables into the ImageSafe. Figure 2-5, indicates the correct location for each cable.

Place the Power  
connector in this  
slot.

Place the USB  
connector in this  
slot.



**Figure 2-5. ImageSafe Cable Clip**

## SECTION 3. OPERATION

This section contains check/ card reading procedures, the LED indicator states and cleaning procedures.

### CHECK READING PROCEDURE

1. Orient the check so the MICR line is down and the printed side faces the center of the ImageSafe Scanner as indicated in Figure 3-1. For more information about the MICR line refer to Appendix A.
2. Place the check so the leading edge is in the open slot. Slide the check forward.
3. When the ImageSafe Scanner detects the presence of the check, the motor will turn on. At this time press the check forward until the unit grabs the check. When this happens, release the check. The check will then be transported around the check path and will exit through the other side.
4. After the check is read, the ImageSafe Scanner will transmit the data as specified by its configuration parameters.
5. Remove the check.

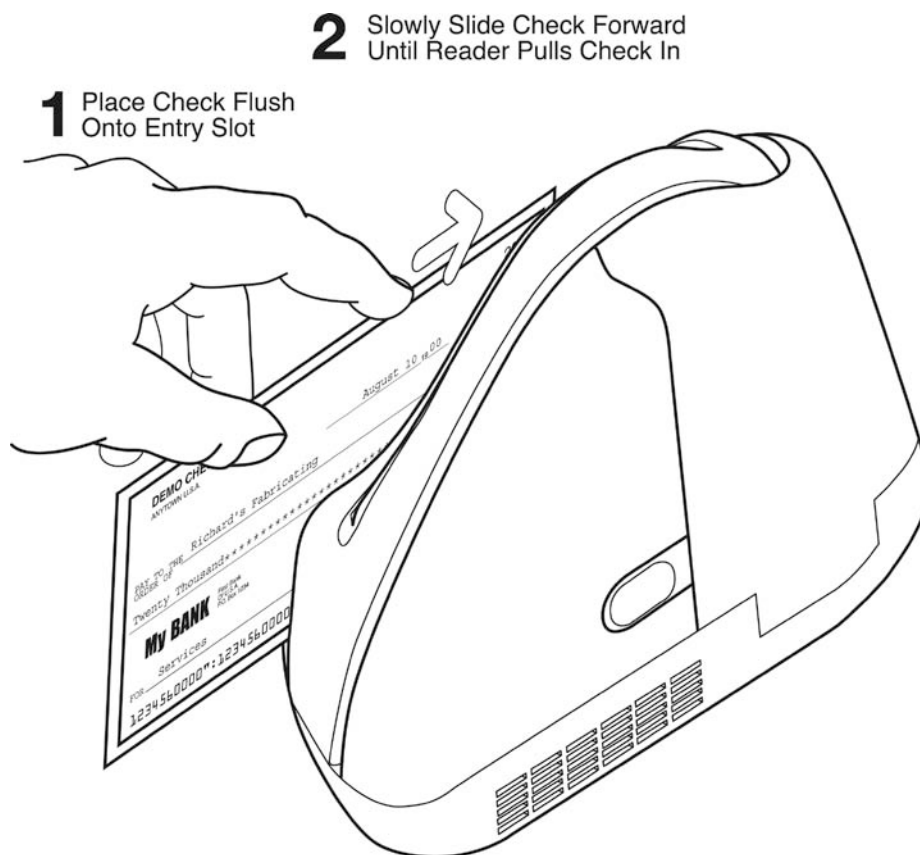

Figure 3-1. Check Orientation - Insertion

## CARD READING PROCEDURE

1. Orient the card so that the magnetic stripe is down and facing away from the logo on the unit and toward the wide color stripe on the MagneSafe reader, as indicated in Figure 3-2.
2. Slide the card in one motion from the top of the unit down through the slot as indicated in the illustration.
3. After the card is read, the ImageSafe will transmit the data as specified by its parameters.

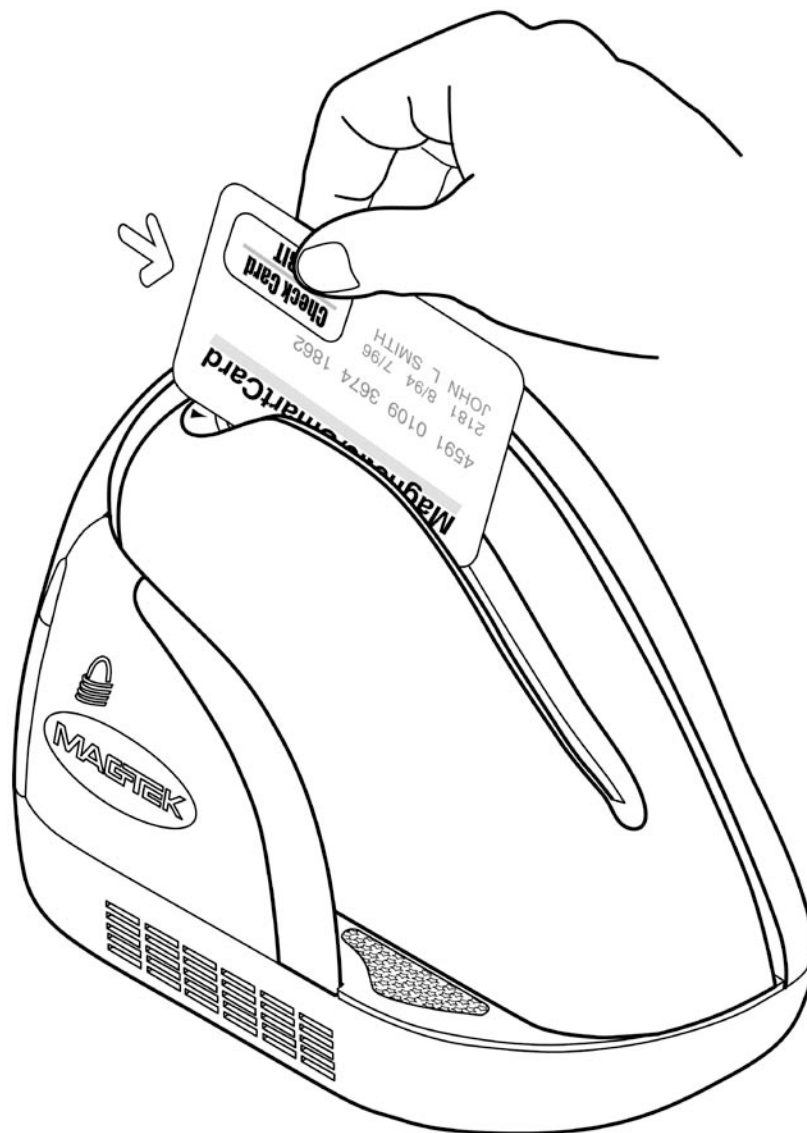

Figure 3-2. MagneSafe Reader Swipe

## LED INDICATORS

Table 3-1 describes the LED indicator conditions for check and card reading operations. The LED indicator is located below the slot where the check is first inserted for reading.

**Table 3-1. LED indicators**

LED INDICATOR	DESCRIPTION
OFF	Power off
SOLID GREEN	Ready to process check or card
BLINKING GREEN	Ready to process check scan or card swipe Collected data is valid and correct
BLINKING AMBER	Check is being processed
SOLID RED	Error collecting data or data is invalid
BLINKING RED	Paper Jam

\*Refer to "Section 4. Troubleshooting Guide."

## CLEANING

Clean the outside of the ImageSafe Scanner with a soft, damp cloth and wipe with a dry cloth.

### *Caution*

*To avoid damaging the read head, do not touch the inside of the check or card paths with a wet cloth.*

Use the Cleaning Swab, P/N 97200078, to clean the Scan Bars as shown and described in the next section.

### Opening the Unit

To open the check path and gain access to the Scan Bars, grip the ImageSafe Scanner hold the unit as shown in Figure 3-3. Press the access latch button with your thumb and the access door will pop open.

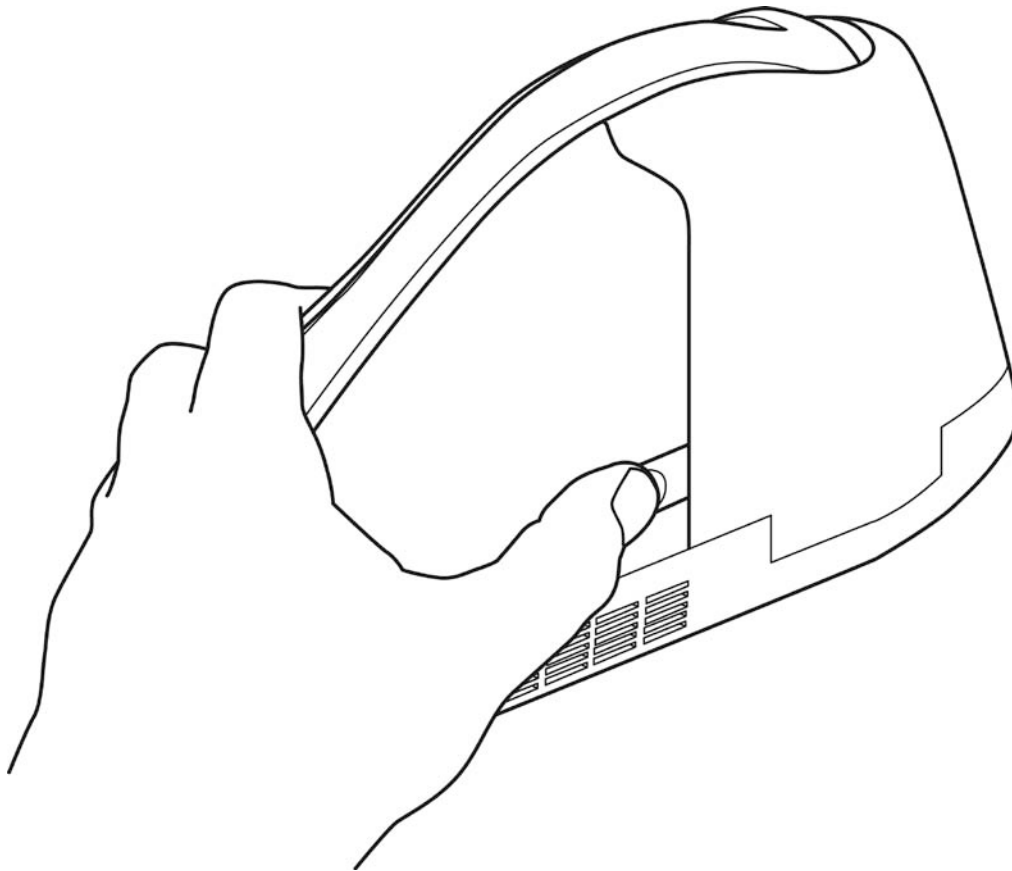

**Figure 3-3. Opening the Unit**

### Cleaning Check Path and Scan Bars

1. When the check path access door is open, as shown in Figure 3-4, check the path for debris. To clean, turn the unit over and tap gently on the bottom.

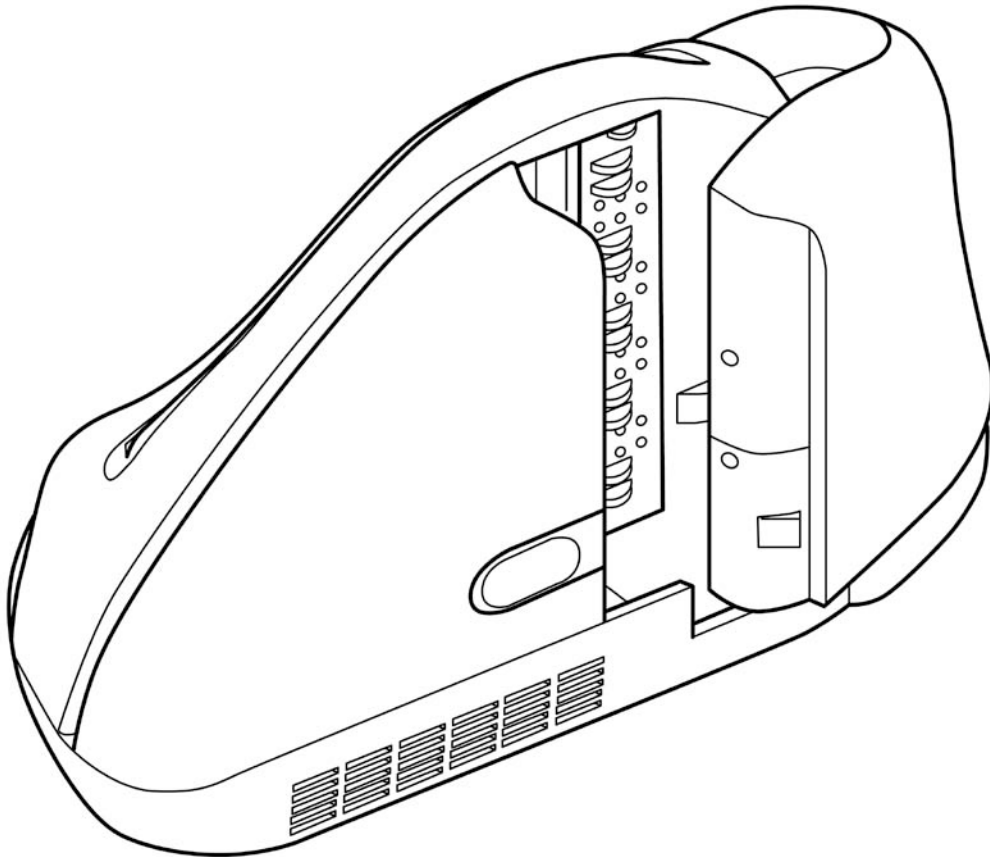

**Figure 3-4. Cleaning Check Path and Scan Bars**

2. Check the scan bars to ensure there is no build-up of ink or paper debris.

3. To clean the scan bars, use the cleaning swab, shown in Figure 3-5. Activate the swab by bending the plastic tube until you hear a snap.
4. Wait until the liquid moves into the sponge tip. It should be damp when touched.

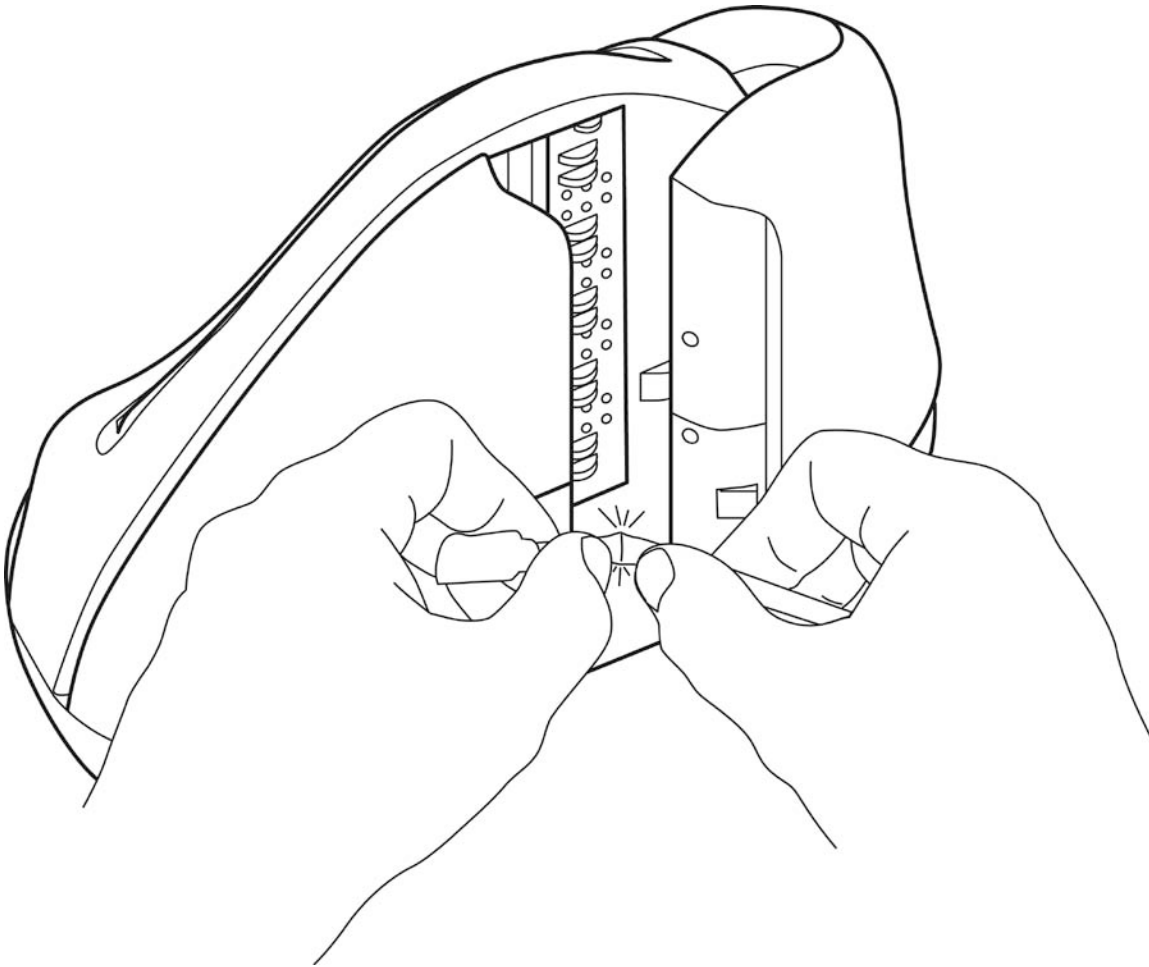

**Figure 3-5. Activating the Cleaning Swab**

5. When the tip of the swab is damp, clean the first scan bar by wiping the swab up and down the scan bar surface as indicated in Figure 3-6.

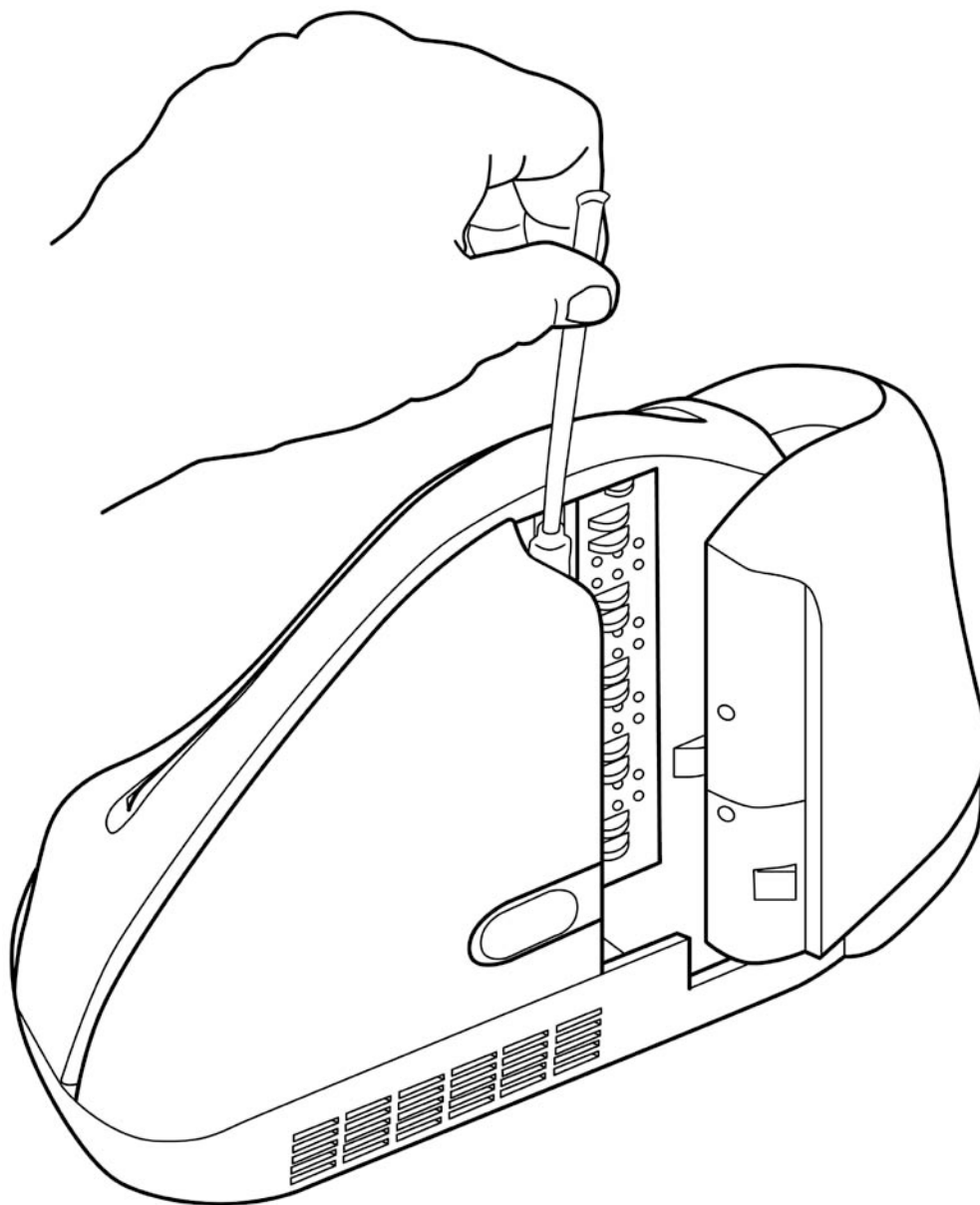

**Figure 3-6. Cleaning the First Scan Bar**

6. After cleaning the first scan bar, clean the second scan bar by again wiping the swab up and down the scan bar surface as indicated in Figure 3-7.

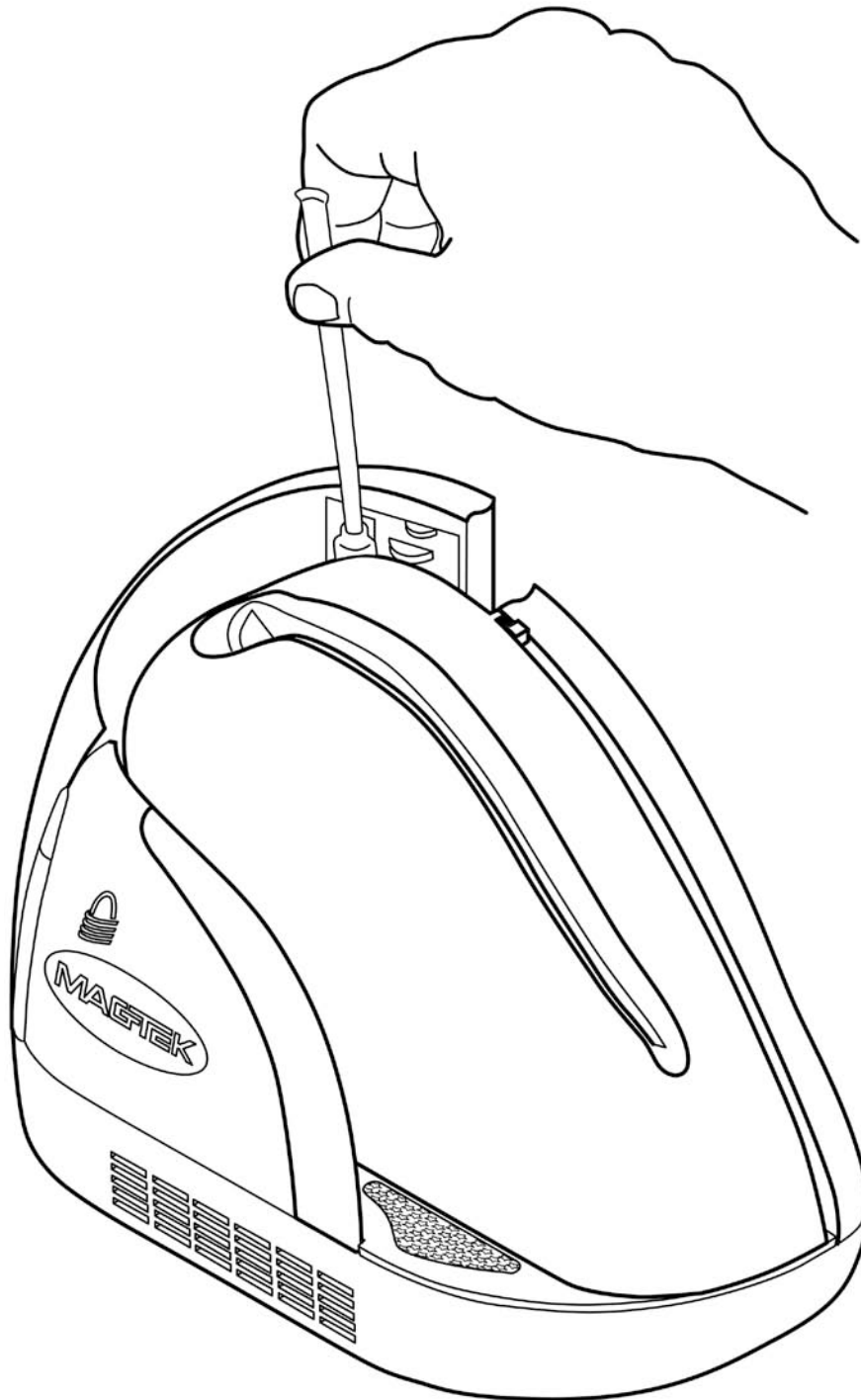

**Figure 3-7. Cleaning the Second Scan Bar**

### Closing the Unit

1. Hold the unit as shown in Figure 3-8. Push the rear access door closed with the right hand while holding on the opposite side with the left hand.
2. The unit is properly closed when the two panels are flush and the latch has "**clicked**" into position.

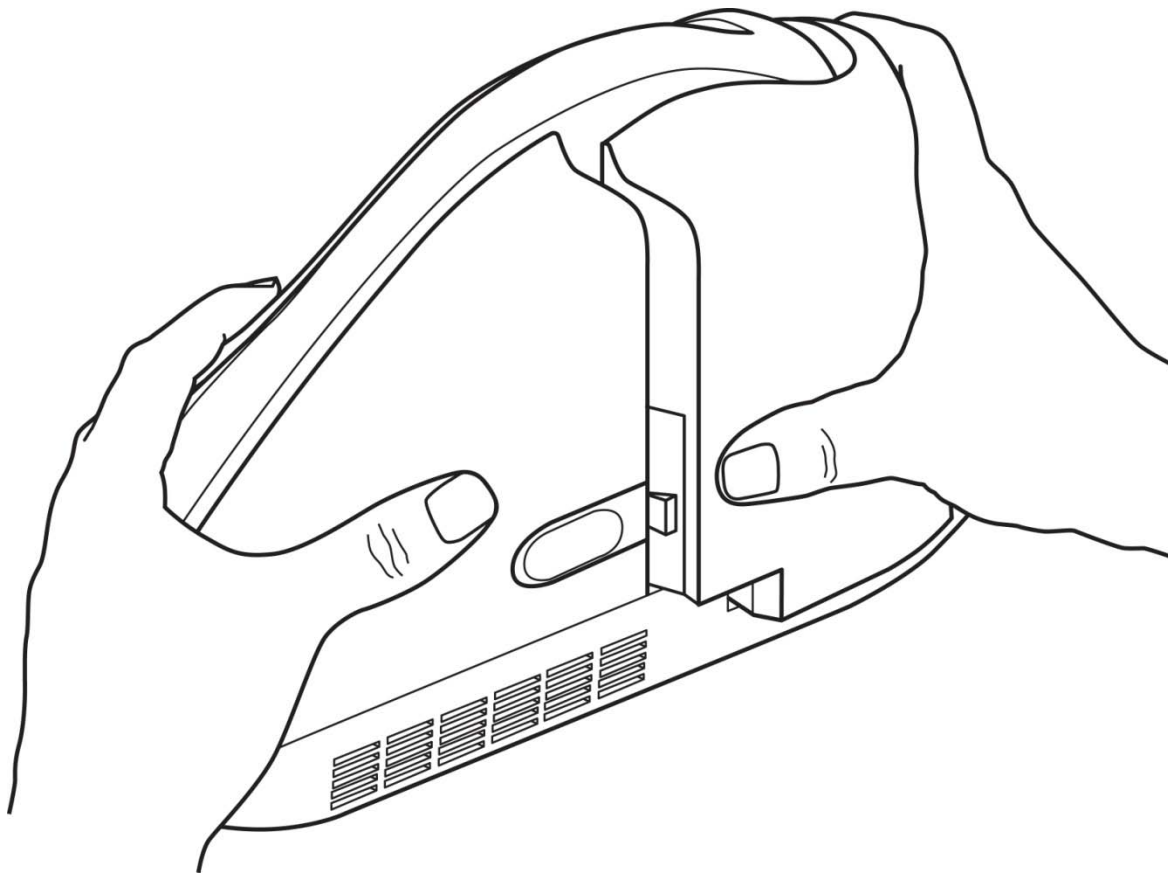

Figure 3-8. Closing the Unit



## SECTION 4. TROUBLESHOOTING GUIDE

### REQUIREMENTS

- Personal Computer.
- USB Interface Cable, Part Number: 22350300
- AC adapter, Part Number: 64300090 (U.S) or 64300080 (International)
- Sample checks, Part Number: 96530005.

### SET-UP

1. Plug USB cable into the ImageSafe Scanner.
2. Plug the other end of the USB cable into the PC.
3. Power on the ImageSafe Scanner.
4. Start trouble-shooting procedure at Step 00.

### TROUBLESHOOTING

<b>00</b>	<b>Check LED</b>
-----------	------------------

Check the status of the LED indicator:

- ◇ Off, continue to step 01.
- ◇ Green, continue to step 02.
- ◇ Blinking red, continue to step 07.
- ◇ Red, continue to step 12.

<b>01</b>	<b>Check the Power to the ImageSafe Scanner</b>
-----------	---

Possible causes for this problem are:

- AC adapter connection to outlet - make sure the AC adapter is securely connected to outlet on the wall or power strip.
- AC adapter connection to ImageSafe Scanner - make sure the AC adapter is securely connected to the power jack on the Cable.
- Power strip - if using a power strip, make sure the strip is connected to outlet on the wall and the switch on the strip is turned on.
- AC adapter is defective - replace the AC adapter.

Determine if any of the conditions described above are true:

- ◇ If yes, rectify and continue to step 00.
- ◇ If no, continue to step 12.

<b>02</b>	<b>Read a check</b>
-----------	---------------------

Read a check through the ImageSafe Scanner:

- ◇ If the check is transported all the way around the check path, continue to step 03.

- ◇ If the check gets "stuck" in the check path, continue to step 06.
- ◇ If the motor does not turn on, continue to step 12.

<b>03</b>	<b>Did PC receive data?</b>
-----------	-----------------------------

After the check is read, did the PC receive any data?

- ◇ If yes, continue to step 04.
- ◇ If no, verify that USB cable is connected

<b>04</b>	<b>Analyze data</b>
-----------	---------------------

Analyze the data received by the PC:

- ◇ If the data is good, continue to step 10.
- ◇ If the data contains one or more '?', continue to step 05.

<b>05</b>	<b>Read error</b>
-----------	-------------------

Possible causes for this problem are:

- Interference - the ImageSafe may be too close to a monitor, AC adapter or magnetic device. Move the ImageSafe away from the source of interference.
- Printing problem - the check being read may not meet the requirements of the ANSI Standards. Use one the sample checks provided by MagTek.
- Feeding the check - do not hold on to the check as it goes around the path. Release the check immediately after the ImageSafe "grabs" it. Also, make sure that the front end is not tilted up while the check is being read.

Determine if any of the conditions described above are true:

- ◇ If yes, rectify and continue to step 02.
- ◇ If no, continue to step 06.

<b>06</b>	<b>Path is obstructed</b>
-----------	---------------------------

Foreign debris obstructing the check path:

- Loose debris - power off the ImageSafe Scanner and refer to Section 3, Check Path Cleaning.
- Wedged debris - the debris is wedged in and cannot be removed with the procedure described above.

Is the foreign debris removable?

- ◇ If yes, remove and continue to step 02.
- ◇ If no, continue to step 12.

<b>07</b>	<b>Blocked sensor or data error</b>
-----------	-------------------------------------

One of the sensors may be blocked by dust build-up or foreign debris (see Figure 4-1 for sensor location) or an error occurred when the MICR\card data was read. To resolve the issue try reinserting the check or re-swiping the card if this does not work process to the sensor.

Use canned air to clean the sensor if this does not work proceed with the steps below.

Power off the ImageSafe Scanner and then power on again, observe the LED indicator:

- ◇ If the LED indicator blinks red, continue to step 12.
- ◇ Any other LED indicator status, continue to step 00.
- ◇ If the LED indicator blinks red/green, continue to step 12.
- ◇ Any other LED indicator status, continue to step 00.

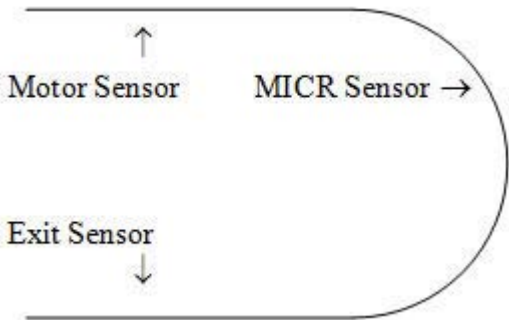

Figure 4-1. Sensor Location

<b>08</b>	<b>No MICR data detected</b>
-----------	------------------------------

Possible causes for this problem are:

- No MICR characters - the ink used to print the MICR characters does not have magnetic properties. Try one of the sample checks provided by MagTek.
- Feeding the check - When feeding the check, make sure that the MICR line is at the bottom and the printed side of the check is facing the MagTek logo on the ImageSafe Scanner.

Determine if any of the conditions described above are true:

- ◇ If yes, rectify and continue to step 02.
- ◇ If no, continue to step 09.

<b>09</b>	<b>Cable problem</b>
-----------	----------------------

Possible causes for this problem are:

- Loose connection - the cable connector on the PC or the ImageSafe Scanner may be loose. Make sure that both connectors are tightly connected.
- Damaged cable - the connectors, pins or wires in the cable may be damaged. Replace cable.

Determine if any of the conditions described above are true:

- ◇ If yes, rectify and continue to step 02.
- ◇ If no, continue to step 12.

<b>10</b>	<b>No problem found</b>
-----------	-------------------------

The ImageSafe Scanner is operating properly. If you have additional concerns or requirements please contact your MagTek representative.

<b>11</b>	<b>Read Insta-Change check</b>
-----------	--------------------------------

Read Insta-Change check with the appropriate settings. Return to step 00. If condition persists, continue to step 12.

<b>12</b>	<b>Return ImageSafe Scanner to MagTek</b>
-----------	---

Possible causes for this problem are:

- USB cable is not connected
- The computer is turned off
- Sensor board is damaged
- Power connection failure

The ImageSafe Scanner has a problem that needs further analysis, testing, and possibly repair. Please contact the MagTek Help Desk at (888) 624-8350, and make arrangements to send the unit back to MagTek. Include a detailed description of the problem.



## APPENDIX A. CHECK READING

The characters printed on the bottom line of commercial and personal checks are special. They are printed with magnetic ink to meet specific standards. These characters can be read by a MICRImage Reader at higher speeds and with more accuracy than manual data entry. Two MICR character sets are used worldwide; they are: E13-B and CMC-7. The E13-B set is used in the US, Canada, Australia, United Kingdom, Japan, India, Mexico, Venezuela, Colombia, and the Far East. The CMC-7 set is used in France, Spain, other Mediterranean countries, and most South American countries.

### E13-B CHARACTER SET

The MICR font character set E13-B includes digits 0 through 9 and four symbols. The numbers found on U.S. checks are of the E13-B character set. The numbers and symbols of E13-B are as follows:

1	6	
2	7	┆┆ Transit symbol
3	8	■ ■ ■ Dash Symbol
4	9	"■ On-U.S. Symbol
5	0	.■ Amount Symbol

### CMC-7 CHARACTER SET

The numbers and symbols of the CMC-7 character set are as follows:

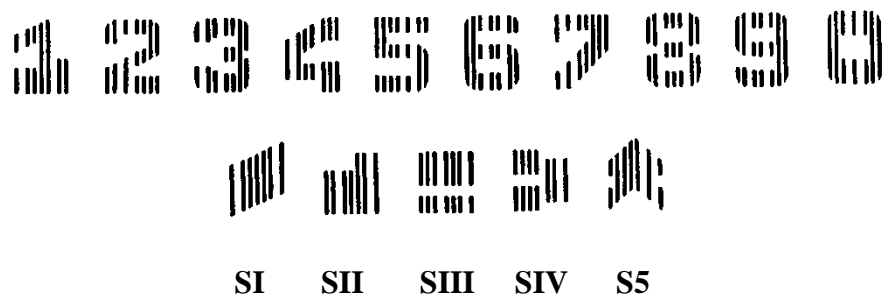

The nonnumeric CMC-7 characters are translated by the ImageSafe Scanner as shown in Table A-1.

**Table A-1. CMC-7 Nonnumeric Characters**

CMC-7 Character	MICRImage Reader Output
SI	A
SII	B
SIII	C
SIV	D
SV	E

### CHECK LAYOUTS

Personal checks with MICR fields are shown in Figure A-1. Business checks are shown in Figure A-2. The digits 1 through 4 in the illustrations are described below under MICR Fields.

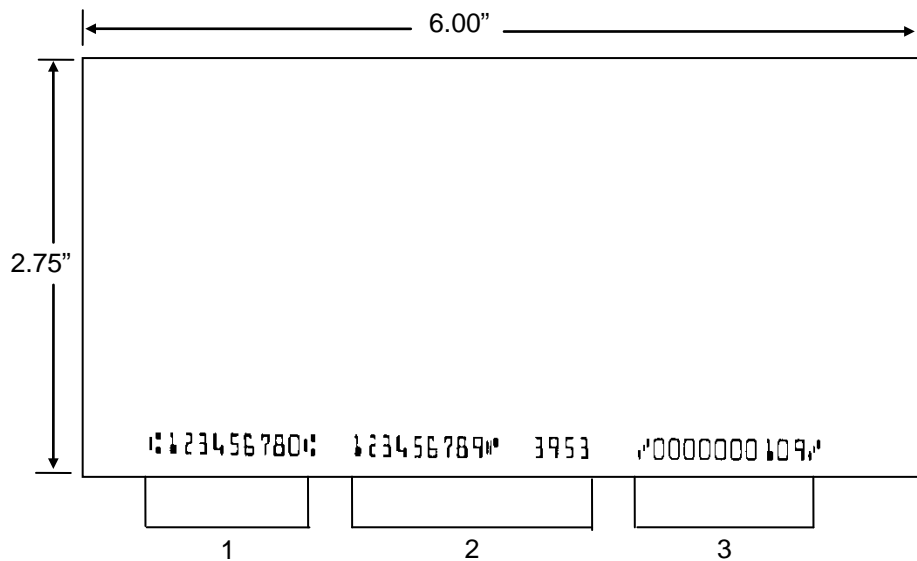

**Figure A-1. Personal Checks**

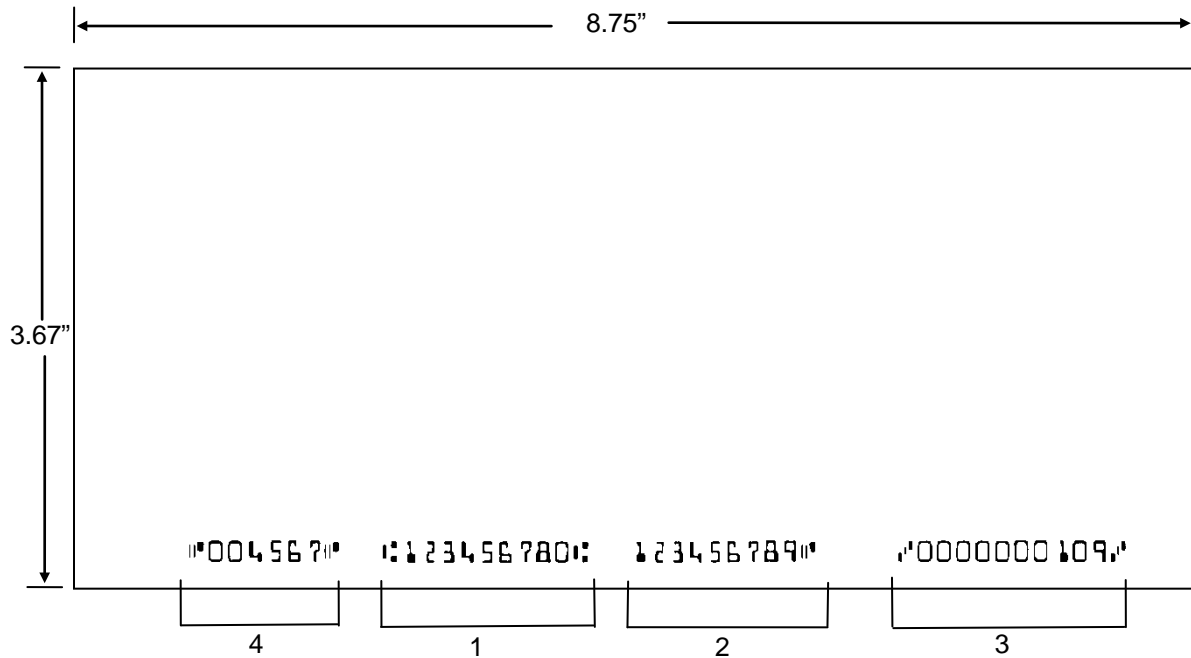

Figure A-2. Business Checks

## MICR FIELDS

The numbers 1 through 4 refer to the numbers below the checks on the illustration and represent the 4 MICR fields.

### 1-Transit Field

The Transit field is a 9-digit field bracketed by two Transit symbols. The field is subdivided as follows:

- Digits 1-4            Federal Reserve Routing Number
- Digits 5-8           Bank ID Number (American Banking Association)
- Digit 9                Check Digit

## **2-On-Us Field**

The On-Us field is variable, up to 19 characters (including symbols). Valid characters are digits, spaces, dashes, and On-Us symbols. The On-Us field contains the account number and may also contain a serial number (Check number) and/or a transaction code. Note that an On-Us symbol must always appear to the right of the account number.

## **3-Amount Field**

The Amount field is a 10-digit field bracketed by Amount symbols. The field is always zero-filled to the left.

## **4-Auxiliary On-Us Field**

The Auxiliary On-Us field is variable, 4-10 digits, bracketed by two On-Us symbols. This field is not present on personal checks. On business checks, this field contains the check serial number.

## APPENDIX B. DEMO SOFTWARE AND USB DRIVERS

To install the ImageSafe Scanner USB drivers and Demo software follow the steps below:

1. Insert the installation software CD into your computer's CD-ROM (or download software directly from the MagTek website: [www.magtek.com](http://www.magtek.com)); the installation application will automatically begin and the screen below will appear. Press [Next] to continue the installation process.

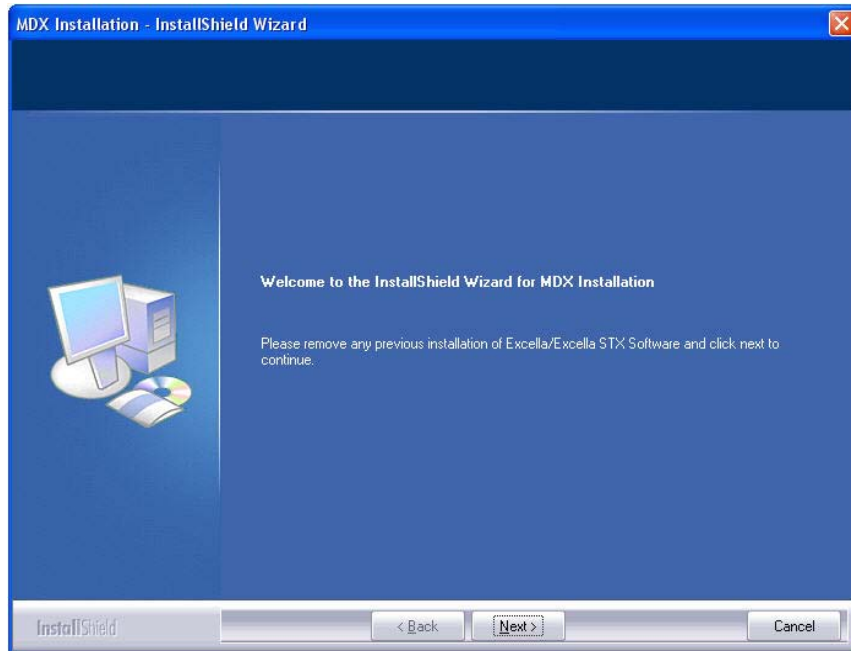

2. At the “Select Options” screen shown below check the options you wish to install and press [Next] to proceed with the installation.

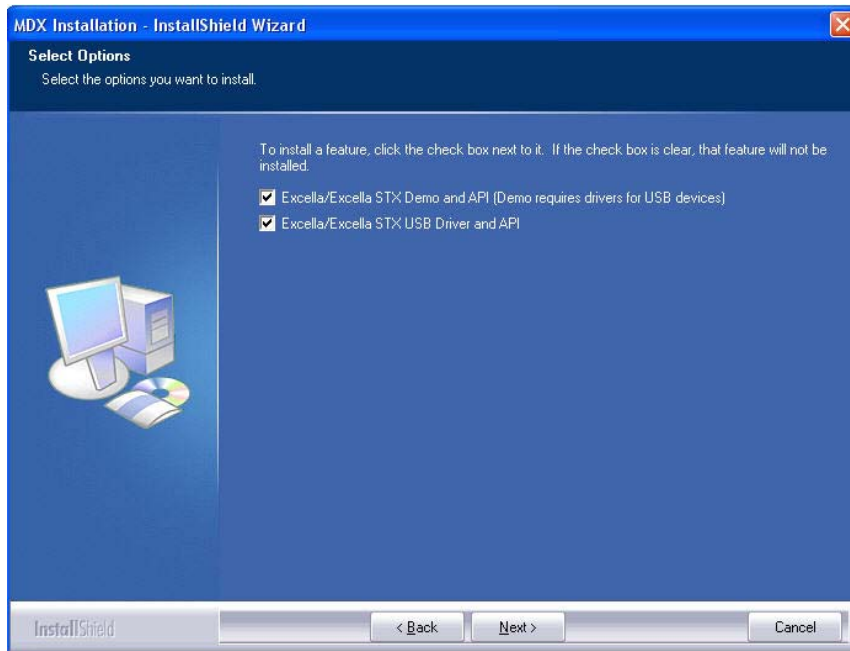

3. The next step in to select the software installation location. Press [Browse] to select a location or press [Next] to except the default location and proceed with the installation.

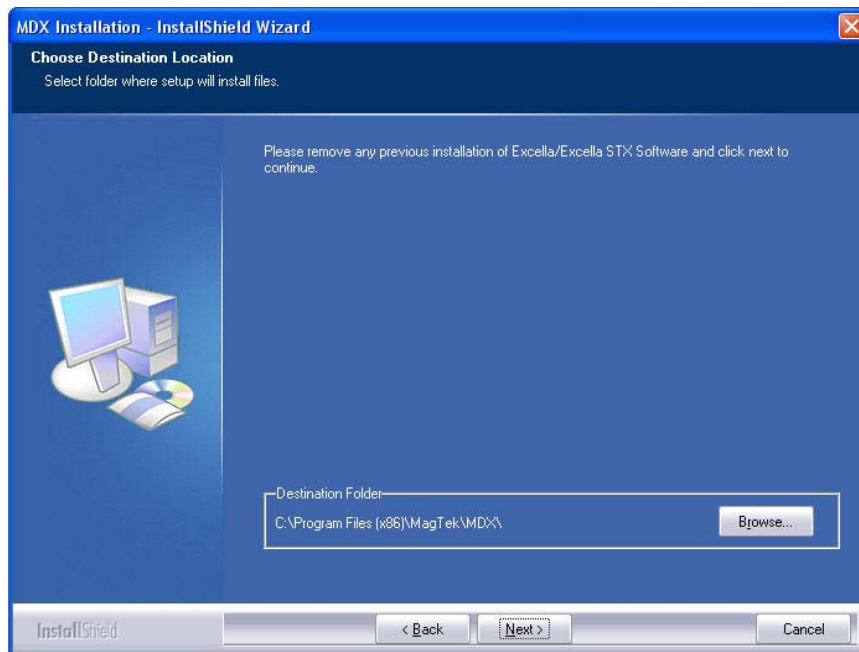

4. The ImageSafe software is now installed press [Finish] to complete the installation process.

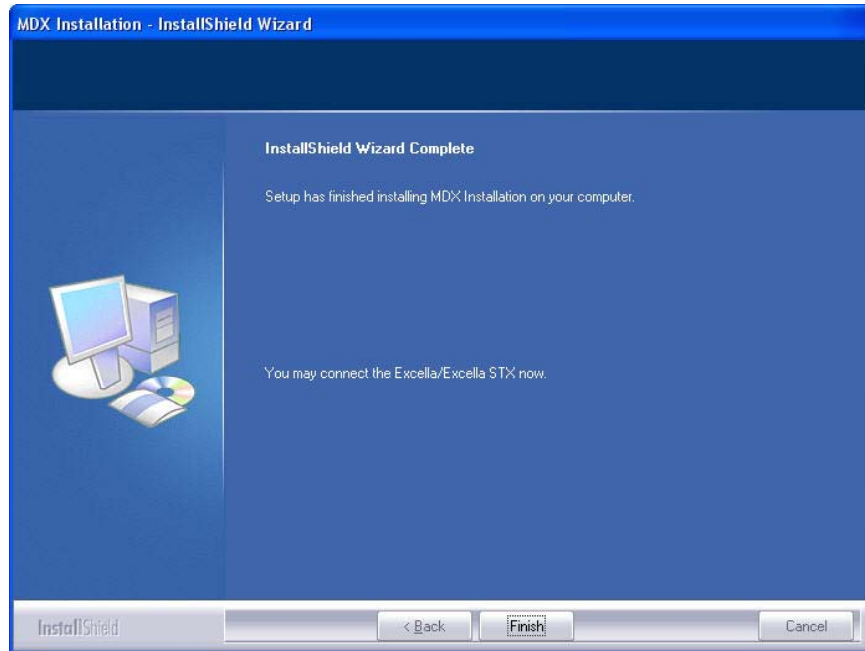

## ImageSafe

---

Once the demo software has been successfully loaded the ImageSafe demo program can be used. To use the demo program, click on the Microsoft Windows Start button. Then navigate to the demo program by clicking on: All **Programs**→**MagTek**→**Excella** and **Excella STX**→**Demo Program**. When the Demo program is selected the window below will be shown.

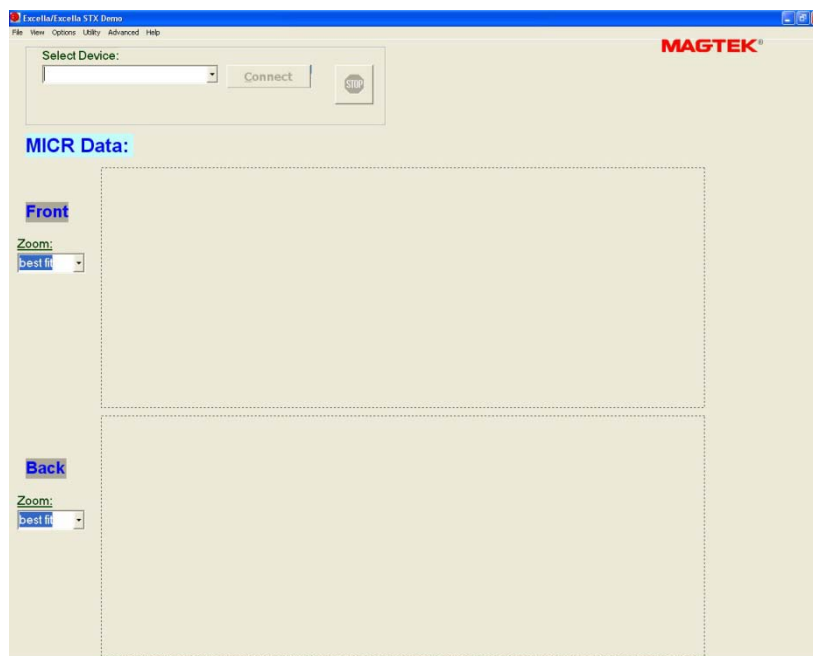

Select '**Excella MDX.MDX001**' from the [Select Device] drop down menu as shown below and press connect; the demo software is now ready to use simply insert a check or swipe a card.

**Notes:**